



TEMPERATURE CONTROL
FOR **TODAY & TOMORROW**

MITSUBISHI
HEAVY INDUSTRIES

FDC140KXZES1-W

Capacitate nominala de racire: **14.0 KW**



Specificatii

Capacitate nominala (cai putere)			5HP
Sursă de alimentare			Trifazic 380-415V 50Hz, 380V 60Hz
Putere de pornire		A	5
Curent maxim admis		A	13.5
Capacitate nominala	Racire	kW	14.0
	Incalzire		14.0
Consumul de energie	Racire	kW	4.00
	Incalzire		3.52
Dimensiuni exterioare	I/L/A	mm	845x970x370
Nivel de presiune sonoră	Racire/Incalzire	dB(A)	54/58
Greutate netă		kg	87
Refrigerant	Tip / GWP		R32 / 675



TEMPERATURE CONTROL FOR TODAY & TOMORROW



Refrigerant	Incarcare	kg/TCO2Eq	4.2/2.835
Dimensiuni țevă refrigerant	Refrigerant lichid	mm(in)	ø9.52(3/8")
Dimensiuni țevă refrigerant	Refrigerant gazos	mm(in)	ø15.88(5/8")
Capacitatea minima/maxima acceptata		%	80-150%
Numarul maxim de unitati interne acceptate			10
SEER / SCOP (Unitate externă)			8.82 / 4.62

Schema tehnica

Unit: mm

All models

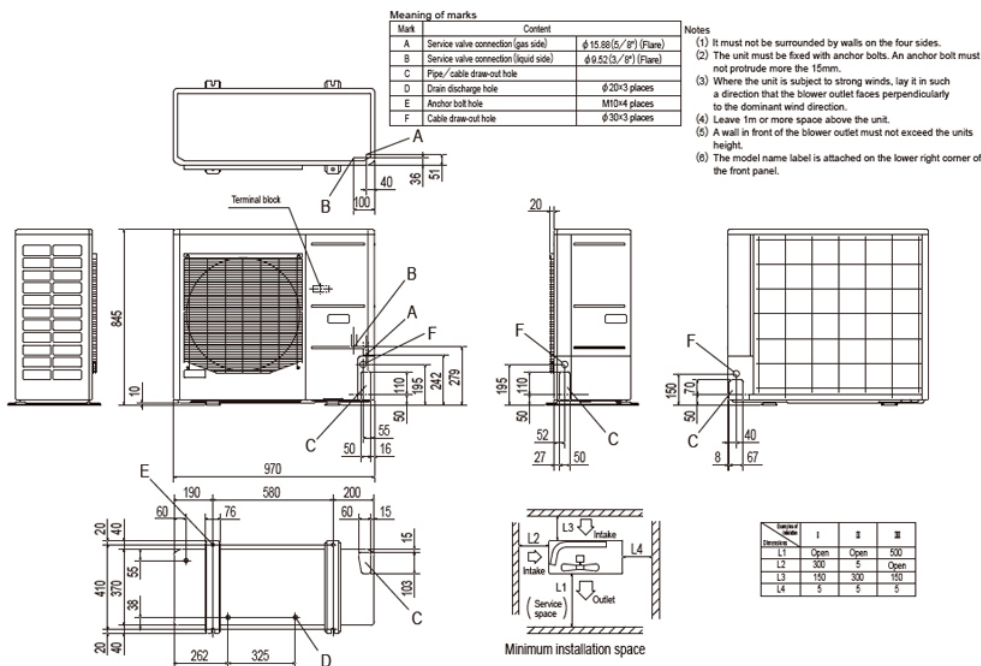

Datorită politicii de continuă îmbunătățire a produselor, ne rezervăm dreptul de a modifica specificațiile tehnice fără nicio notificare prealabilă.