



TEMPERATURE CONTROL
FOR **TODAY & TOMORROW**

MITSUBISHI
HEAVY INDUSTRIES

FDC335KXZE2

Capacitate nominala de racire: **33.5 KW**



Specificatii

Capacitate nominala (cai putere)			12HP
Sursă de alimentare			Trifazic 380-415V, 50Hz
Putere de pornire		A	5
Curent maxim admis		A	20.1
Capacitate nominala	Racire	kW	33.5
	Incalzire		37.5
Consumul de energie	Racire	kW	8.98
	Incalzire		9.03
Dimensiuni exterioare	I/L/A	mm	1697x1350x720
Nivel de presiune sonoră	Racire/Incalzire	dB(A)	63/62
Greutate netă		kg	288
Refrigerant	Tip / GWP		R410A / 2088
Refrigerant	Incarcare	kg/TCO2Eq	11.0 / 22.968



TEMPERATURE CONTROL FOR TODAY & TOMORROW



Dimensiuni țevă refrigerant	Refrigerant lichid	mm(in)	ø12.7(1/2")
Dimensiuni țevă refrigerant	Refrigerant gazos	mm(in)	ø25.4(1") [ø22.22(7/8")]
Capacitatea minima/maxima acceptata		%	50~200
Numarul maxim de unitati interne acceptate			44

Schema tehnica

Dimensions

All measurements in mm.

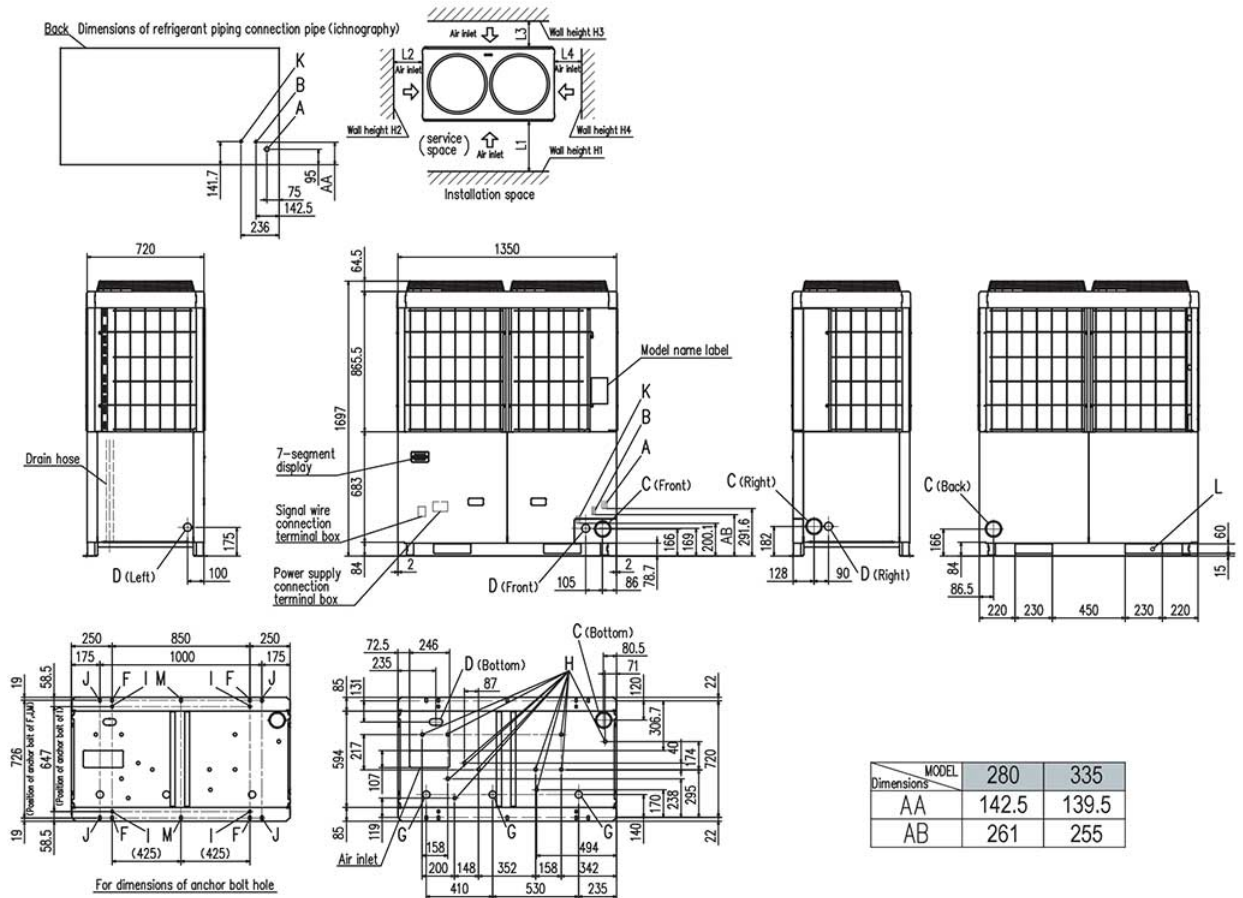

Datorită politicii de continuă îmbunătățire a produselor, ne rezervăm dreptul de a modifica specificațiile tehnice fără nicio notificare prealabilă.