



TEMPERATURE CONTROL
FOR **TODAY & TOMORROW**

MITSUBISHI
HEAVY INDUSTRIES

FDE100VNAPVH

Capacitate nominala de racire: **10.0 KW**



Poze unitate interna si unitate externa



Specificatii

Unitate internă		FDE50VH x 2	
Unitate externă		FDC100VNA	
Sursă de alimentare		Monofazic 220-240V, 50Hz / 220V, 60Hz	
Capacitate nominală de răcire (Min-Max)		kW	10.0 (4.0 ~ 11.2)
Capacitate nominală de încălzire (Min-Max)		kW	11.2 (4.0 ~ 12.5)
Power Consumption	Răcire/Încălzire	kW	3.12 / 2.99
EER/COP	Răcire/Încălzire	kW	3.21 / 3.75



TEMPERATURE CONTROL FOR TODAY & TOMORROW



Curent de intrare			A	5
Max. current			A	24
Nivel putere sonoră*1	U.I.*3	Răcire/Încălzire	dB(A)	60 / 60
	U.E.	Răcire/Încălzire		70 / 70
Nivel presiune sonoră*1	U.I.*3	Răcire (P-Hi/Hi/Me/Lo)		46 / 38 / 36 / 31
		Încălzire (P-Hi/Hi/Me/Lo)		46 / 38 / 36 / 31
	U.E.	Răcire/Încălzire		54 / 56
Flux de aer	U.I.*3	Răcire (P-Hi/Hi/Me/Lo)	m ³ /min	13 / 10 / 9 / 7
		Încălzire (P-Hi/Hi/Me/Lo)		13 / 10 / 9 / 7
	U.E.	Răcire/Încălzire		75 / 73
Exterior dimensions	U.I.	HeightxWidthxDepth	mm	210 x 1,070 x 690
	U.E.		mm	845 x 970 x 370
Greutate netă		U.I./U.E.	kg	28 / 80
Refrigerant charge			kg/TCO ₂ E	3.8/7.934
Refrigerant Type GWP				R410A/2088
Ref.piping size	Lichid/Gaz		Ț, mm	9.52(3/8") / 15.88(5/8")
Lungime țeavă refrigerant (o direcție)			m	Max. 50
Diferență de nivel suportată	Unitate externă este mai sus/mai jos		m	Max.50 / Max.15
Interval de funcționare - temperatură exterioară		Răcire*2	°C	-15~50

Datorită politicii de continuă îmbunătățire a produselor, ne rezervăm dreptul de a modifica specificațiile tehnice fără nicio notificare prealabilă.



TEMPERATURE CONTROL FOR TODAY & TOMORROW



Încălzire	°C	-20~20	
Filtru de aer, cantitate			Pocket plastic net x 2(lavabil)
Telecomandă (opțional)			Cu fir:RC-EX3A, RC-E5, RCH-E3 Wireless:RCN-E-E3
Clasa Energetică (Răcire/Încălzire)			A+/A+
SEER			5.71
SCOP (Climat temperat)			4.10
Pdesign (răcire/încălzire(@-10°C))			10.0/8.5
Annual Electricity Consumption			613/2905
Performanța pe modul încălzire			Climat temperat

Schema tehnica

Datorită politicii de continuă îmbunătățire a produselor, ne rezervăm dreptul de a modifica specificațiile tehnice fără nicio notificare prealabilă.



TEMPERATURE CONTROL FOR TODAY & TOMORROW



Models FDE40VH, 50VH

Note (1) The model name label is attached on the fan casing inside the air return grille.

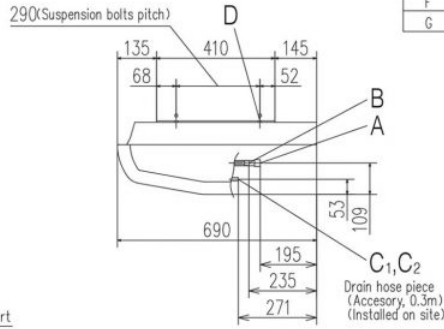
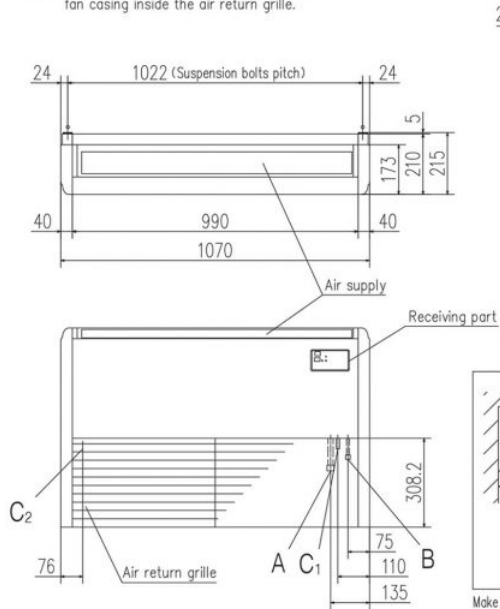

Symbol	Content	
A	Gas piping	φ12.7 (1/2") (Flare)
B	Liquid piping	φ6.35 (1/4") (Flare)
C 1,2	Drain piping	VP20 (I.D.20, O.D.26)
D	Hole for suspension bolts	(M10 or M8)
E	Back cutout	PE cover
F	Top cutout	Plate cover
G	Drain piping (for left back)	(Knock out)

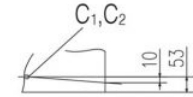

Note) The slope of drain piping inside the unit must take decline of 10mm.

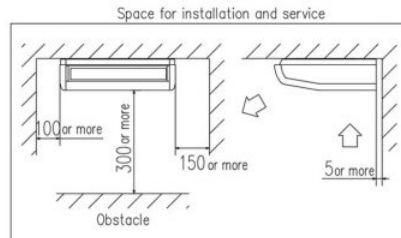
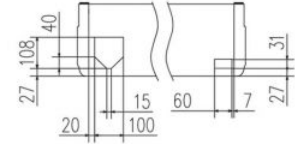

Make a space of 4000 or more between the units when installing more than one.

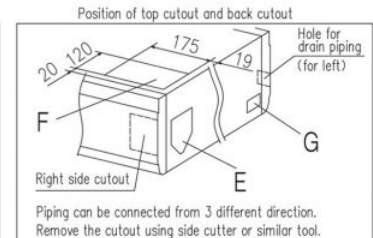

Piping can be connected from 3 different direction. Remove the cutout using side cutter or similar tool.

Datorită politicii de continuă îmbunătățire a produselor, ne rezervăm dreptul de a modifica specificațiile tehnice fără nicio notificare prealabilă.



TEMPERATURE CONTROL FOR TODAY & TOMORROW



FDC100VNA, 125VNA, 140VNA
100VSA, 125VSA, 140VSA

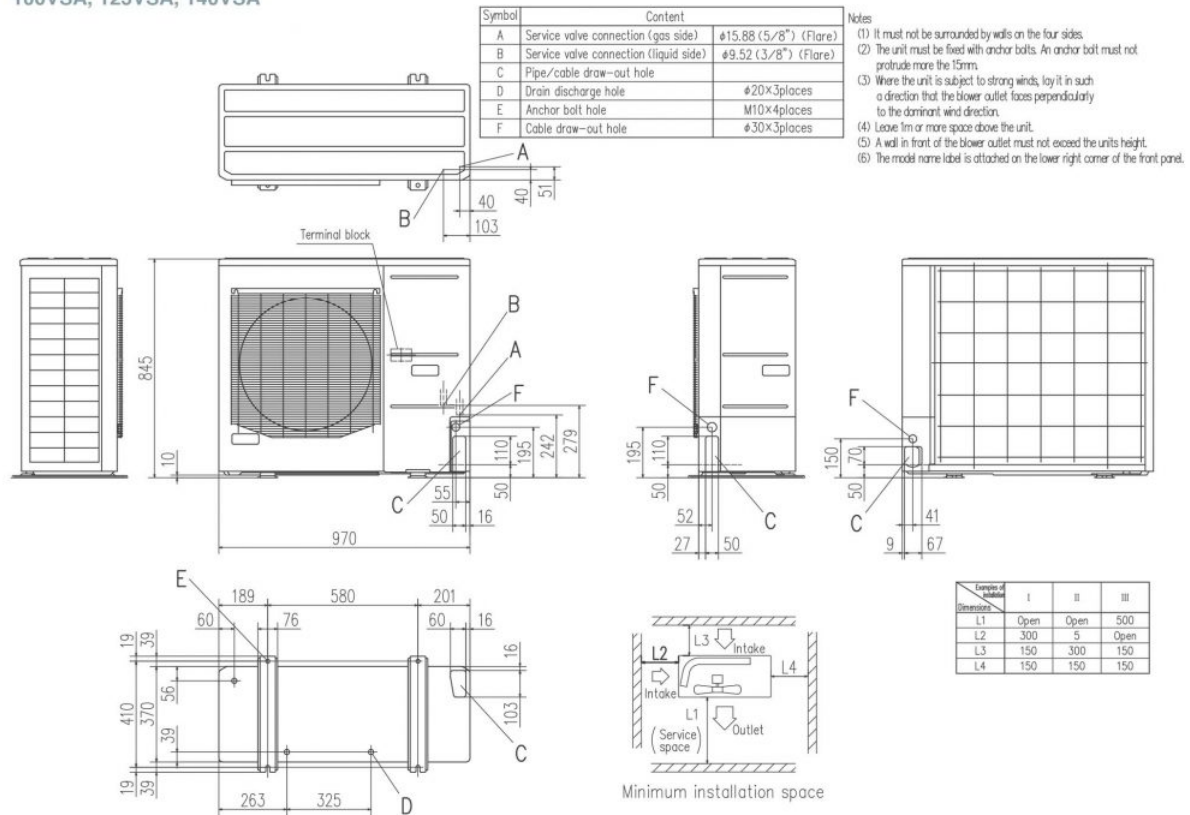

Datorită politicii de continuă îmbunătățire a produselor, ne rezervăm dreptul de a modifica specificațiile tehnice fără nicio notificare prealabilă.