



TEMPERATURE CONTROL  
FOR **TODAY & TOMORROW**

**MITSUBISHI**  
HEAVY INDUSTRIES

## FDE100VSPVH

Capacitate nominala de racire: **10.0 KW**



## Poze unitate interna si unitate externa



## Specificatii

Unitate internă		FDE50VH x 2	
Unitate externă		FDC100VSX	
Sursă de alimentare		Trifazic 380-415V, 50Hz / 380V, 60Hz	
Capacitate nominală de răcire (Min-Max)		kW	10.0 ( 4.0 ~ 11.2 )
Capacitate nominală de încălzire (Min-Max)		kW	11.2 ( 4.0 ~ 16.0 )
Power Consumption	Răcire/Încălzire	kW	3.00 / 3.39
EER/COP	Răcire/Încălzire	kW	3.33 / 3.30



## TEMPERATURE CONTROL FOR TODAY & TOMORROW



Curent de intrare			A	5
Max. current			A	15
Nivel putere sonoră*1	U.I.*3	Răcire/Încălzire	dB(A)	60 / 60
	U.E.	Răcire/Încălzire		70 / 70
Nivel presiune sonoră*1	U.I.*3	Răcire (P-Hi/Hi/Me/Lo)		46 / 38 / 36 / 31
		Încălzire (P-Hi/Hi/Me/Lo)		46 / 38 / 36 / 31
	U.E.	Răcire/Încălzire		48 / 50
Flux de aer	U.I.*3	Răcire (P-Hi/Hi/Me/Lo)	m <sup>3</sup> /min	13 / 10 / 9 / 7
		Încălzire (P-Hi/Hi/Me/Lo)		13 / 10 / 9 / 7
	U.E.	Răcire/Încălzire		100 / 100
Exterior dimensions	U.I.	HeightxWidthxDepth	mm	210 x 1,070 x 690
	U.E.		mm	1,300 x 970 x 370
Greutate netă		U.I./U.E.	kg	28 / 105
Refrigerant charge			kg/TCO <sub>2</sub> E	4.5/9.396
Refrigerant Type GWP				R410A/2088
Ref.piping size	Lichid/Gaz		Ț, mm	9.52(3/8") / 15.88(5/8")
Lungime țeavă refrigerant (o direcție)			m	Max. 100
Diferență de nivel suportată	Unitate externă este mai sus/mai jos		m	Max.30 / Max.15
Interval de funcționare - temperatură exterioară		Răcire*2	°C	-15~43

**Datorită politicii de continuă îmbunătățire a produselor, ne rezervăm dreptul de a modifica specificațiile tehnice fără nicio notificare prealabilă.**



## TEMPERATURE CONTROL FOR TODAY & TOMORROW



Încălzire	°C	-20~20	
Filtru de aer, cantitate			Pocket plastic net x 2(lavabil)
Telecomandă (opțional)			Cu fir:RC-EX3A, RC-E5, RCH-E3 Wireless:RCN-E-E3
Clasa Energetică (Răcire/Încălzire)			A/A
SEER			5.49
SCOP (Climat temperat)			3.94
Pdesign (răcire/încălzire(@-10°C))			10.0/10.8
Annual Electricity Consumption			638/3841
Performanța pe modul încălzire			Climat temperat

## Schema tehnica

---

**Datorită politicii de continuă îmbunătățire a produselor, ne rezervăm dreptul de a modifica specificațiile tehnice fără nicio notificare prealabilă.**



# TEMPERATURE CONTROL FOR TODAY & TOMORROW



## Models FDE40VH, 50VH

Note (1) The model name label is attached on the fan casing inside the air return grille.

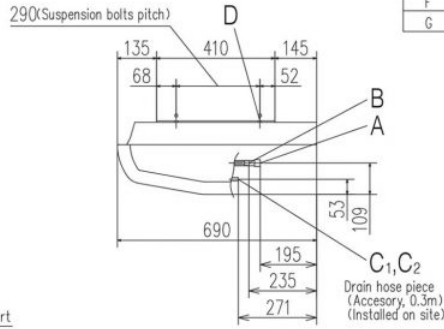
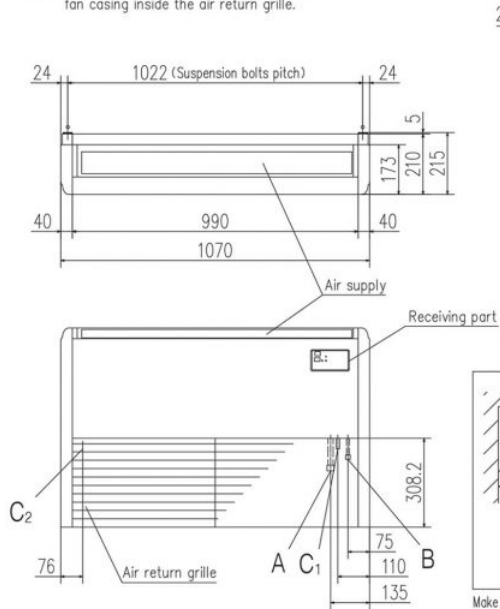

Symbol	Content	
A	Gas piping	φ12.7 (1/2") (Flare)
B	Liquid piping	φ6.35 (1/4") (Flare)
C 1,2	Drain piping	VP20 (I.D.20, O.D.26)
D	Hole for suspension bolts	(M10 or M8)
E	Back cutout	PE cover
F	Top cutout	Plate cover
G	Drain piping (for left back)	(Knock out)

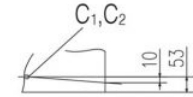

Note) The slope of drain piping inside the unit must take decline of 10mm.

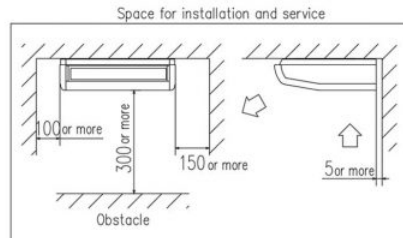
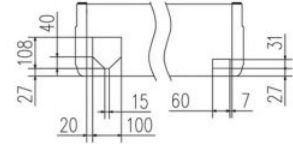

Make a space of 4000 or more between the units when installing more than one.

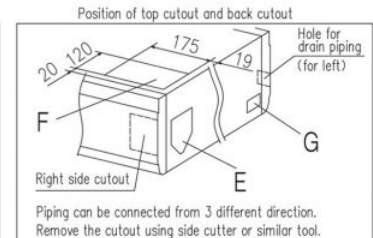

Piping can be connected from 3 different direction. Remove the cutout using side cutter or similar tool.

**Datorită politicii de continuă îmbunătățire a produselor, ne rezervăm dreptul de a modifica specificațiile tehnice fără nicio notificare prealabilă.**



# TEMPERATURE CONTROL FOR TODAY & TOMORROW



FDC100VNX, 100VSX, 125VNX, 125VSX,  
140VNX, 140VSX

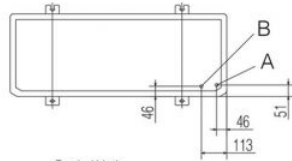

Symbol	Content
A	Service valve connection of the attached connecting pipe (gas side) $\phi 15.88$ (5/8") (Flare)
B	Service valve connection (liquid side) $\phi 9.52$ (3/8") (Flare)
C	Pipe / cable draw-out hole
D	Drain discharge hole $\phi 20 \times 3$ places
E	Anchor bolt hole M10 $\times 4$ places
F	Cable draw-out hole $\phi 30$ (front) $\phi 45$ (side) $\phi 50$ (back)

Notes

- (1) It must not be surrounded by walls on the four sides.
- (2) The unit must be fixed with anchor bolts. An anchor bolt must not protrude more than 15mm.
- (3) Where the unit is subject to strong winds, lay it in such a direction that the blower outlet faces perpendicularly to the dominant wind direction.
- (4) Leave 1m or more space above the unit.
- (5) A wall in front of the blower outlet must not exceed the unit's height.
- (6) The model name label is attached on the lower right corner of the front panel.
- (7) Connect the Service valve with local pipe by using the pipe of the attachment. (Gas side only)

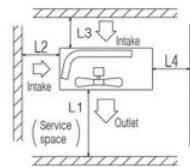
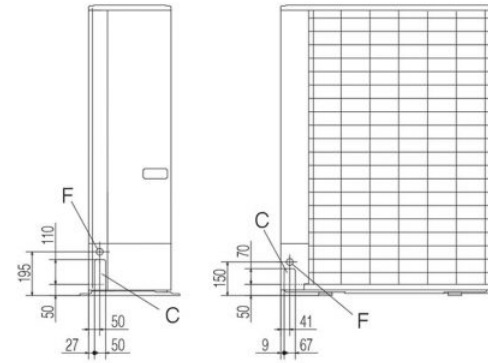
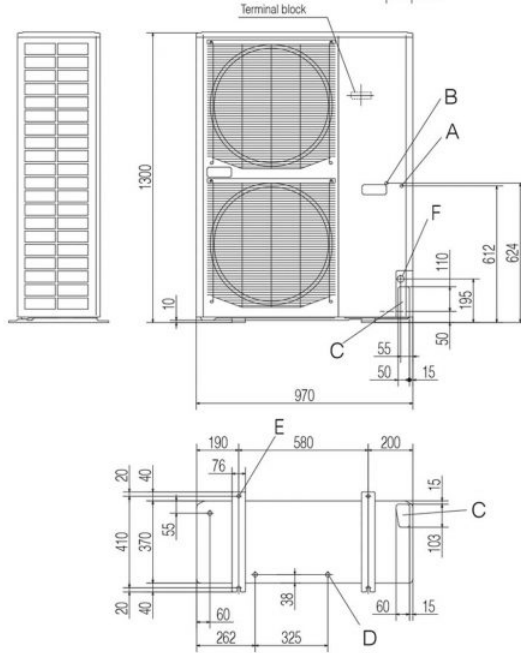

Minimum installation space

Examples of Dimensions	Examples of Installation		
	I	II	III
L1	Open	Open	500
L2	300	5	Open
L3	150	300	150
L4	5	5	5

**Datorită politicii de continuă îmbunătățire a produselor, ne rezervăm dreptul de a modifica specificațiile tehnice fără nicio notificare prealabilă.**