



TEMPERATURE CONTROL
FOR **TODAY & TOMORROW**

MITSUBISHI
HEAVY INDUSTRIES

FDE125VNAPVH

Capacitate nominala de racire: **12.5 KW**



Poze unitate interna si unitate externa



Specificatii

Unitate internă		FDE60VH x 2	
Unitate externă		FDC125VNA	
Sursă de alimentare		Monofazic 220-240V, 50Hz / 220V, 60Hz	
Capacitate nominală de răcire (Min-Max)		kW	12.5 (5.0 ~ 14.0)
Capacitate nominală de încălzire (Min-Max)		kW	14.0 (4.0 ~ 16.0)
Power Consumption	Răcire/Încălzire	kW	4.16 / 3.54
EER/COP	Răcire/Încălzire	kW	3.00 / 3.95



TEMPERATURE CONTROL FOR TODAY & TOMORROW



Curent de intrare			A	5
Max. current			A	24
Nivel putere sonoră*1	U.I.*3	Răcire/Încălzire	dB(A)	60 / 60
	U.E.	Răcire/Încălzire		71 / 71
Nivel presiune sonoră*1	U.I.*3	Răcire (P-Hi/Hi/Me/Lo)		47 / 41 / 37 / 32
		Încălzire (P-Hi/Hi/Me/Lo)		47 / 41 / 37 / 32
	U.E.	Răcire/Încălzire		55 / 57
Flux de aer	U.I.*3	Răcire (P-Hi/Hi/Me/Lo)	m ³ /min	20 / 16 / 13 / 10
		Încălzire (P-Hi/Hi/Me/Lo)		20 / 16 / 13 / 10
	U.E.	Răcire/Încălzire		75 / 73
Exterior dimensions	U.I.	HeightxWidthxDepth	mm	210 x 1,320 x 690
	U.E.		mm	845 x 970 x 370
Greutate netă		U.I./U.E.	kg	33 / 80
Refrigerant Type GWP				R410A/2088
Ref.piping size	Lichid/Gaz		Ț,mm	9.52(3/8") / 15.88(5/8")
Lungime țeavă refrigerant (o direcție)			m	Max. 50
Diferență de nivel suportată	Unitate externă este mai sus/mai jos		m	Max.50 / Max.15
Interval de funcționare - temperatură exterioară	Răcire*2		°C	-15~50
	Încălzire		°C	-20~20

Datorită politicii de continuă îmbunătățire a produselor, ne rezervăm dreptul de a modifica specificațiile tehnice fără nicio notificare prealabilă.



TEMPERATURE CONTROL FOR TODAY & TOMORROW



Filtru de aer, cantitate		Pocket plastic net x 2(lavabil)
Telecomandă (opțional)		Cu fir:RC-EX3A, RC-E5, RCH-E3 Wireless:RCN-E-E3

Schema tehnica

Models FDE60VH, 71VH

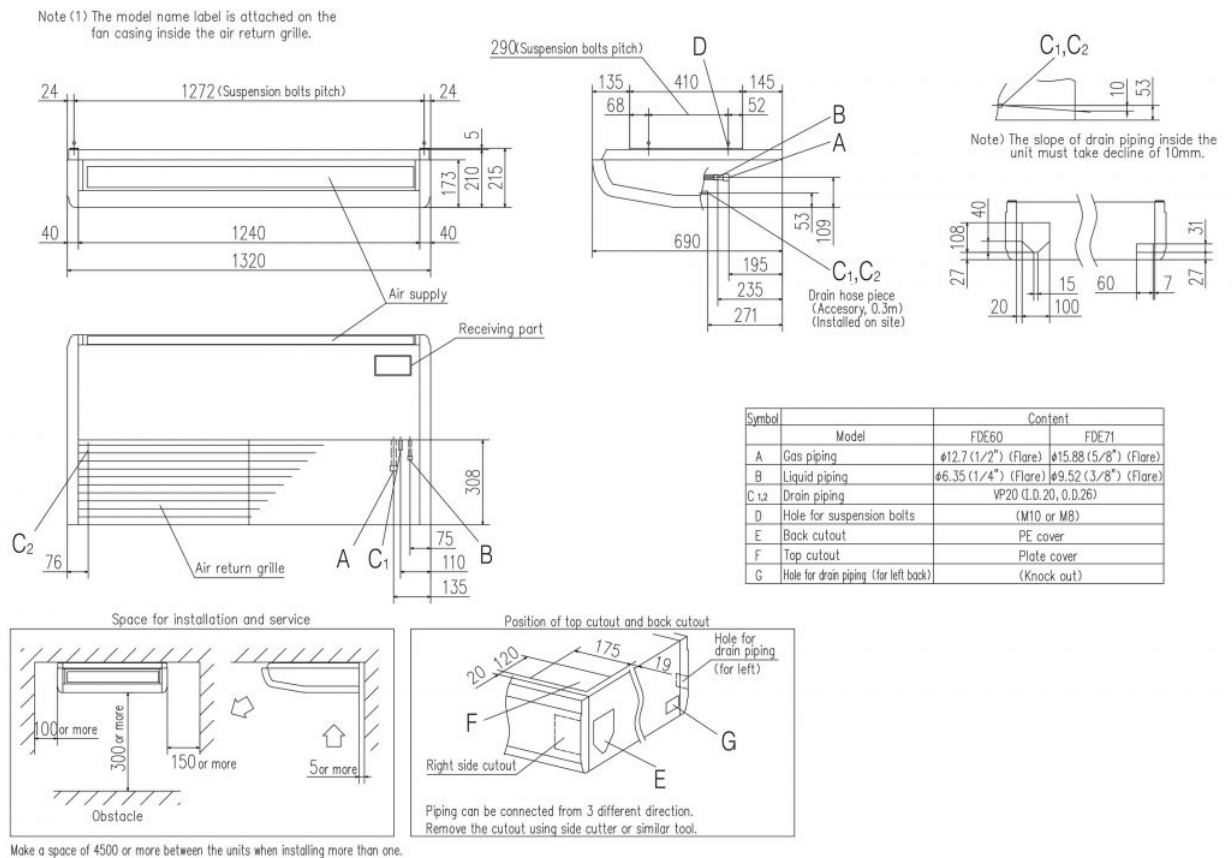

Datorită politicii de continuă îmbunătățire a produselor, ne rezervăm dreptul de a modifica specificațiile tehnice fără nicio notificare prealabilă.



TEMPERATURE CONTROL FOR TODAY & TOMORROW



FDC100VNA, 125VNA, 140VNA
100VSA, 125VSA, 140VSA

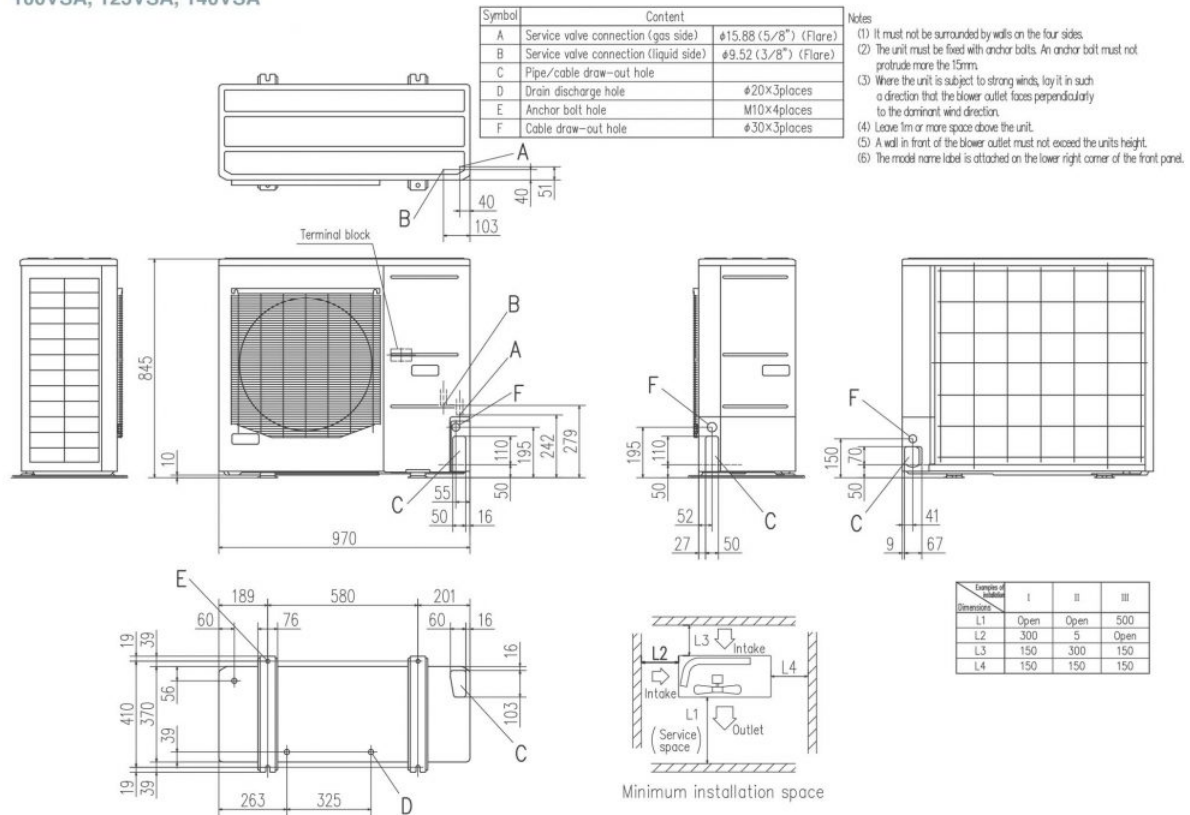

Datorită politicii de continuă îmbunătățire a produselor, ne rezervăm dreptul de a modifica specificațiile tehnice fără nicio notificare prealabilă.