



TEMPERATURE CONTROL
FOR **TODAY & TOMORROW**

MITSUBISHI
HEAVY INDUSTRIES

FDE125VSXVH

Capacitate nominala de racire: **12.5 KW**



Poze unitate interna si unitate externa



Specificatii

Unitate internă		FDE125VH	
Unitate externă		FDC125VSX	
Sursă de alimentare		Trifazic 380-415V, 50Hz / 380V, 60Hz	
Capacitate nominală de răcire (Min~Max)		kW	12.5 (5.0 ~ 14.0)
Capacitate nominală de încălzire (Min~Max)		kW	14.0 (4.0 ~ 18.0)
Consum de energie	Răcire/Încălzire	kW	3.50 / 3.77
EER/COP	Răcire/Încălzire		3.57 / 3.71



TEMPERATURE CONTROL FOR TODAY & TOMORROW



Curent de intrare		A	5	
Amperaj maxim		A	15	
Nivel putere sonoră*1	U.I.	Răcire/Încălzire	dB(A)	64 / 64
	U.E.	Răcire/Încălzire		70 / 70
Nivel presiune sonoră*1	U.I.	Răcire (Hi/Me/Lo/Ulo)		48 / 45 / 40 / 35
		Încălzire (Hi/Me/Lo/Ulo)		48 / 45 / 40 / 35
	U.E.	Răcire/Încălzire		48 / 50
Flux de aer	U.I.	Răcire (Hi/Me/Lo/Ulo)	m ³ /min	32 / 29 / 23 / 17
		Încălzire (Hi/Me/Lo/Ulo)		32 / 29 / 23 / 17
	U.E.	Răcire/Încălzire		100 / 100
Dimensiuni exterioare	U.I.	Înălțime / Lățime / Adâncime	mm	250 x 1,620 x 690
	U.E.			1,300 x 970 x 370
Greutate netă	U.I. / U.E.		kg	43 / 105
Refrigerant		Tip/GWP		R410A/2088
Dimensiuni țevă refrigerant		Lichid/Gaz	mm/ø	9.52(3/8") / 15.88(5/8")
Lungime țevă refrigerant (o direcție)			m	Max.100
Diferență de nivel suportată		Unitate externă este mai sus/mai jos	m	Max.30 / Max.15
Interval de funcționare - temperatură exterioară		Răcire*2	°C	-15~43

Datorită politicii de continuă îmbunătățire a produselor, ne rezervăm dreptul de a modifica specificațiile tehnice fără nicio notificare prealabilă.



TEMPERATURE CONTROL FOR TODAY & TOMORROW



Încălzire	-20~20	
Filtru de aer (cantitate)		2 x Filtre lavabile din plastic
Telecomandă (opțional)		Cu fir:RC-EX3A, RC-E5, RCH-E3 Wireless:RCN-E-E3
SEER		5.74
SCOP (Climat temperat)		3.66

Schema tehnica

Models FDE100VH, 125VH, 140VH

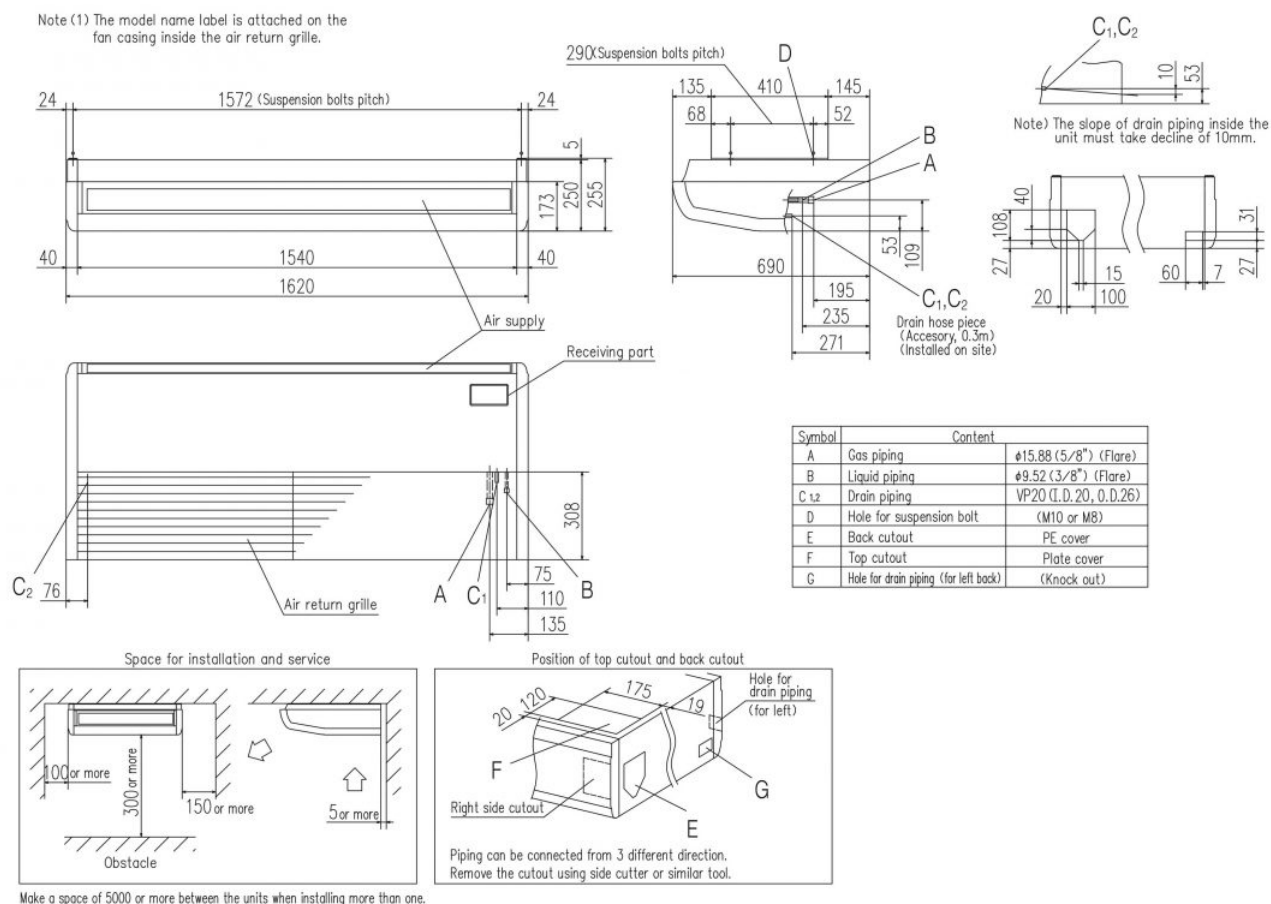

Datorită politicii de continuă îmbunătățire a produselor, ne rezervăm dreptul de a modifica specificațiile tehnice fără nicio notificare prealabilă.



TEMPERATURE CONTROL FOR TODAY & TOMORROW



FDC100VNX, 100VSX, 125VNX, 125VSX,
140VNX, 140VSX

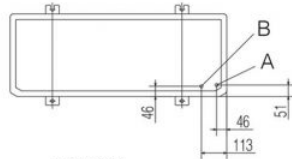

Symbol	Content
A	Service valve connection of the attached connecting pipe (gas side) $\phi 15.88$ (5/8") (Flare)
B	Service valve connection (liquid side) $\phi 9.52$ (3/8") (Flare)
C	Pipe / cable draw-out hole
D	Drain discharge hole $\phi 20 \times 3$ places
E	Anchor bolt hole M10 \times 4places
F	Cable draw-out hole $\phi 30$ (front) $\phi 45$ (side) $\phi 50$ (back)

Notes

- (1) It must not be surrounded by walls on the four sides.
- (2) The unit must be fixed with anchor bolts. An anchor bolt must not protrude more than 15mm.
- (3) Where the unit is subject to strong winds, lay it in such a direction that the blower outlet faces perpendicularly to the dominant wind direction.
- (4) Leave 1m or more space above the unit.
- (5) A wall in front of the blower outlet must not exceed the unit's height.
- (6) The model name label is attached on the lower right corner of the front panel.
- (7) Connect the Service valve with local pipe by using the pipe of the attachment. (Gas side only)

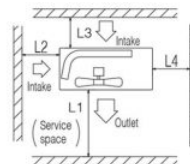
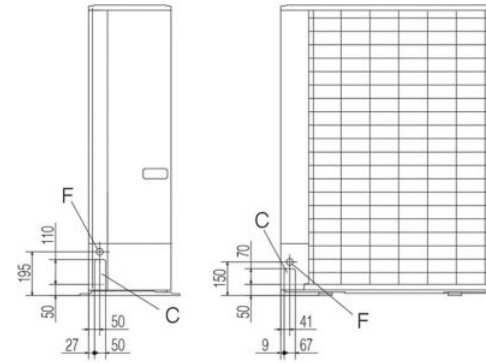
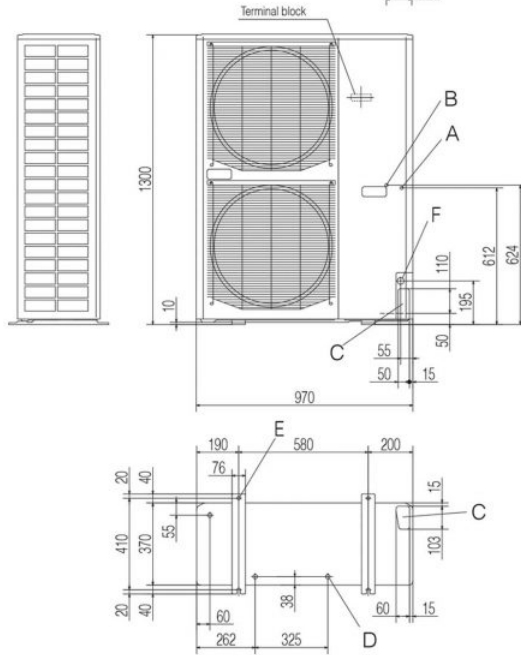

Minimum installation space

Examples of Dimensions	Examples of Installation		
	I	II	III
L1	Open	Open	500
L2	300	5	Open
L3	150	300	150
L4	5	5	5

Datorită politicii de continuă îmbunătățire a produselor, ne rezervăm dreptul de a modifica specificațiile tehnice fără nicio notificare prealabilă.