



TEMPERATURE CONTROL  
FOR **TODAY & TOMORROW**

  
**MITSUBISHI**  
**HEAVY INDUSTRIES**

## FDE140VSATVH

Capacitate nominala de racire: **13.6 KW**



## Poze unitate interna si unitate externa



## Specificatii

Unitate internă		FDE50VH x 3	
Unitate externă		FDC140VSA	
Sursă de alimentare		Trifazic 380-415V, 50Hz / 380V, 60Hz	
Capacitate nominală de răcire (Min-Max)		kW	13.6 ( 5.0 ~ 14.5 )
Capacitate nominală de încălzire (Min-Max)		kW	15.5 ( 4.0 ~ 16.5 )
Power Consumption	Răcire/Încălzire	kW	4.74 / 4.21
EER/COP	Răcire/Încălzire	kW	2.87 / 3.68



## TEMPERATURE CONTROL FOR TODAY & TOMORROW



Curent de intrare			A	5
Max. current			A	15
Nivel putere sonoră*1	U.I.*3	Răcire/Încălzire	dB(A)	60 / 60
	U.E.	Răcire/Încălzire		73 / 73
Nivel presiune sonoră*1	U.I.*3	Răcire (P-Hi/Hi/Me/Lo)		46 / 38 / 36 / 31
		Încălzire (P-Hi/Hi/Me/Lo)		46 / 38 / 36 / 31
	U.E.	Răcire/Încălzire		57 / 59
Flux de aer	U.I.*3	Răcire (P-Hi/Hi/Me/Lo)	m <sup>3</sup> /min	13 / 10 / 9 / 7
		Încălzire (P-Hi/Hi/Me/Lo)		13 / 10 / 9 / 7
	U.E.	Răcire/Încălzire		75 / 73
Exterior dimensions	U.I.	HeightxWidthxDepth	mm	210 x 1,070 x 690
	U.E.		mm	845 x 970 x 370
Greutate netă		U.I./U.E.	kg	28 / 82
Refrigerant Type GWP				R410A/2088
Ref.piping size	Lichid/Gaz		Ț,mm	9.52(3/8") / 15.88(5/8")
Lungime țeavă refrigerant (o direcție)			m	Max. 50
Diferență de nivel suportată	Unitate externă este mai sus/mai jos		m	Max.50 / Max.15
Interval de funcționare - temperatură exterioară	Răcire*2		°C	-15~50
	Încălzire		°C	-20~20

**Datorită politicii de continuă îmbunătățire a produselor, ne rezervăm dreptul de a modifica specificațiile tehnice fără nicio notificare prealabilă.**



# TEMPERATURE CONTROL FOR TODAY & TOMORROW



Filtru de aer, cantitate	Pocket plastic net x 2(lavabil)
Telecomandă (opțional)	Cu fir:RC-EX3A, RC-E5, RCH-E3 Wireless:RCN-E-E3

## Schema tehnica

### Models FDE40VH, 50VH

Note (1) The model name label is attached on the fan casing inside the air return grille.

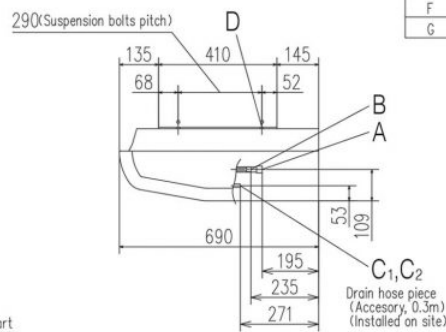
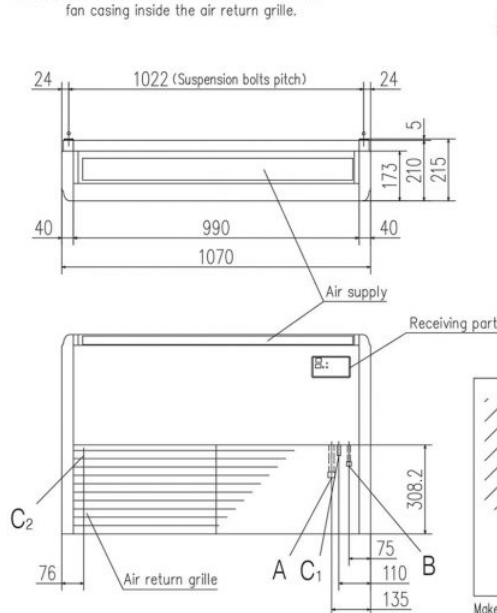

Symbol	Content	
A	Gas piping	φ12.7 (1/2") (Flare)
B	Liquid piping	φ6.35 (1/4") (Flare)
C 1,2	Drain piping	VP20 (I.D.20, O.D.26)
D	Hole for suspension bolts	(M10 or M8)
E	Back cutout	PE cover
F	Top cutout	Plate cover
G	Drain piping (for left back)	(Knock out)

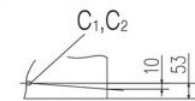

Note) The slope of drain piping inside the unit must take decline of 10mm.

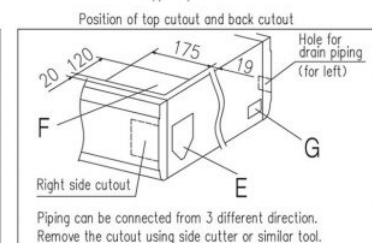
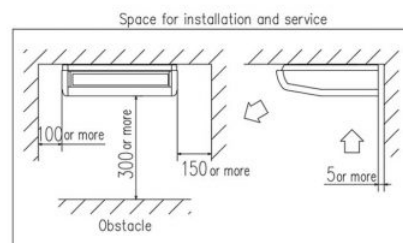
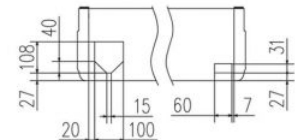

Make a space of 4000 or more between the units when installing more than one.

**Datorită politicii de continuă îmbunătățire a produselor, ne rezervăm dreptul de a modifica specificațiile tehnice fără nicio notificare prealabilă.**



# TEMPERATURE CONTROL FOR TODAY & TOMORROW



FDC100VNA, 125VNA, 140VNA  
100VSA, 125VSA, 140VSA

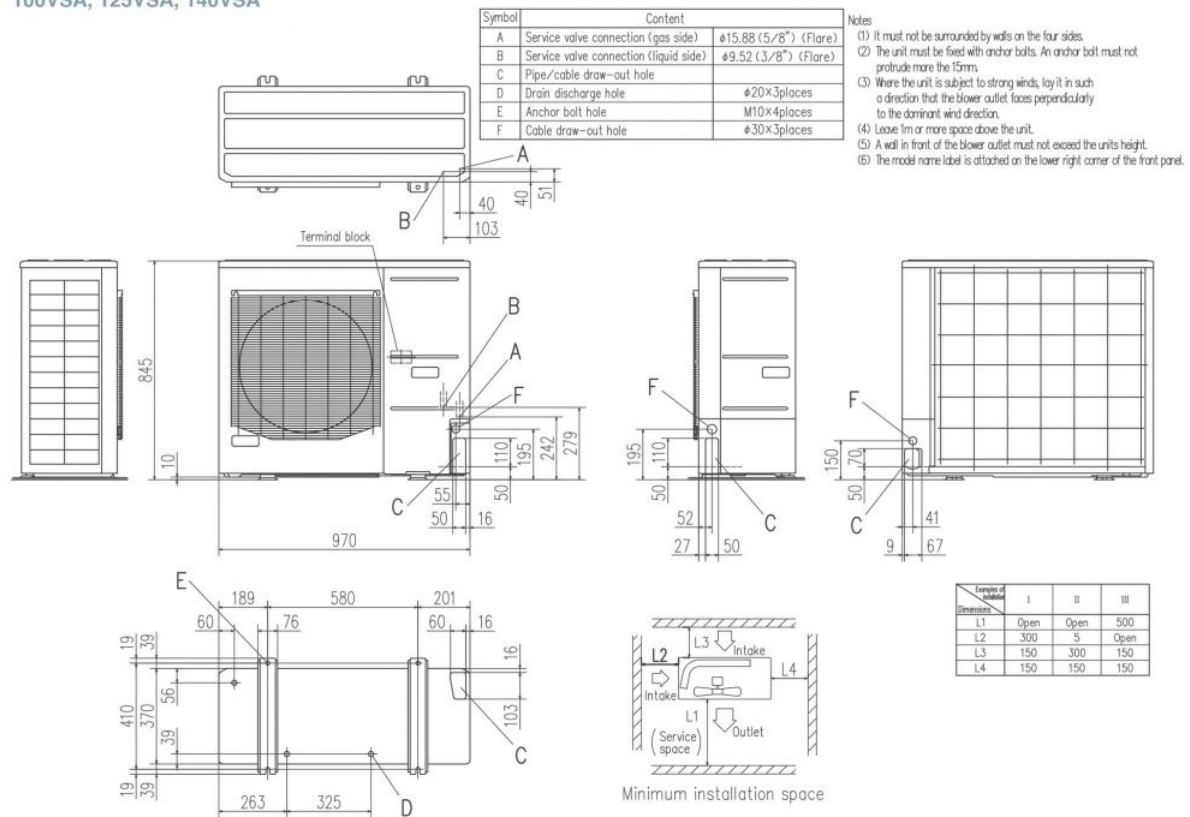

**Datorită politicii de continuă îmbunătățire a produselor, ne rezervăm dreptul de a modifica specificațiile tehnice fără nicio notificare prealabilă.**