



TEMPERATURE CONTROL
FOR **TODAY & TOMORROW**

MITSUBISHI
HEAVY INDUSTRIES

FDE200VSATVH

Capacitate nominala de racire: **19.0 KW**



Poze unitate interna si unitate externa



Specificatii

Unitate internă		FDE71VH x 3	
Unitate externă		FDC200VSA	
Sursă de alimentare		Trifazic 380-415V, 50Hz / 380V, 60Hz	
Capacitate nominală de răcire (Min-Max)		kW	19.0(5.2~22.4)
Capacitate nominală de încălzire (Min-Max)		kW	22.4(3.3~25.0)
Power Consumption	Răcire/Încălzire	kW	6.33 / 5.94
EER/COP	Răcire/Încălzire	kW	3.00 / 3.77



TEMPERATURE CONTROL FOR TODAY & TOMORROW



Curent de intrare			A	5
Max. current			A	20
Nivel putere sonoră*1	U.I.*3	Răcire/Încălzire	dB(A)	60 / 60
	U.E.	Răcire/Încălzire		72 / 74
Nivel presiune sonoră*1	U.I.*3	Răcire (P-Hi/Hi/Me/Lo)		47 / 41 / 37 / 32
		Încălzire (P-Hi/Hi/Me/Lo)		47 / 41 / 37 / 32
	U.E.	Răcire/Încălzire		58 / 59
Flux de aer	U.I.*3	Răcire (P-Hi/Hi/Me/Lo)	m ³ /min	20 / 16 / 13 / 10
		Încălzire (P-Hi/Hi/Me/Lo)		20 / 16 / 13 / 10
	U.E.	Răcire/Încălzire		135 / 135
Exterior dimensions	U.I.	HeightxWidthxDepth	mm	210 x 1,320 x 690
	U.E.		mm	1,300 x 970 x 370
Greutate netă		U.I./U.E.	kg	33 / 115
Refrigerant Type GWP				R410A/2088
Ref.piping size	Lichid/Gaz		Ț,mm	9.52(3/8") / 22.22(7/8")
Lungime țeavă refrigerant (o direcție)			m	Max.70
Diferență de nivel suportată	Unitate externă este mai sus/mai jos		m	Max.30 / Max.15
Interval de funcționare - temperatură exterioară	Răcire*2		°C	-15~50
	Încălzire		°C	-15~20

Datorită politicii de continuă îmbunătățire a produselor, ne rezervăm dreptul de a modifica specificațiile tehnice fără nicio notificare prealabilă.



TEMPERATURE CONTROL FOR TODAY & TOMORROW



Filtru de aer, cantitate		Pocket plastic net x 2(lavabil)
Telecomandă (opțional)		Cu fir:RC-EX3A, RC-E5, RCH-E3 Wireless:RCN-E-E3

Schema tehnica

Models FDE60VH, 71VH

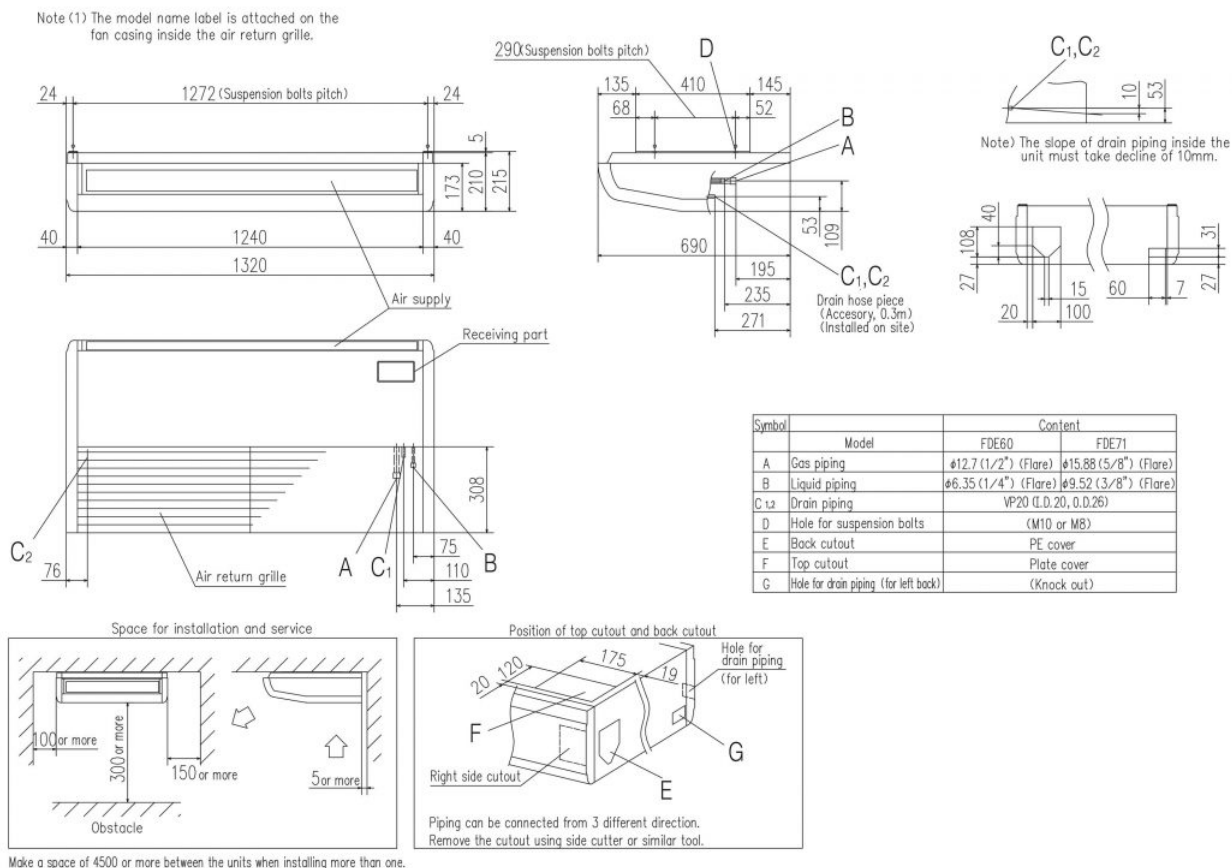

Datorită politicii de continuă îmbunătățire a produselor, ne rezervăm dreptul de a modifica specificațiile tehnice fără nicio notificare prealabilă.



TEMPERATURE CONTROL FOR TODAY & TOMORROW



FDC200VSA

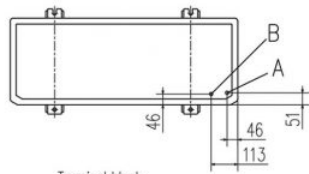

Symbol	Content	
A	Service valve connection of the attached connecting pipe (gas side)	φ19.05 (3/4") (Flare)
B	Service valve connection (liquid side)	φ9.52 (3/8") (Flare)
C	Pipe/cable draw-out hole	
D	Drain discharge hole	φ20×3places
E	Anchor bolt hole	M10×4places
F	Cable draw-out hole	φ30 (front) φ30 (side) φ30 (back)

Notes

- (1) It must not be surrounded by walls on the four sides.
- (2) The unit must be fixed with anchor bolts. An anchor bolt must not protrude more than 15mm.
- (3) Where the unit is subject to strong winds, lay it in such a direction that the blower outlet faces perpendicularly to the dominant wind direction.
- (4) Leave 1m or more space above the unit.
- (5) A wall in front of the blower outlet must not exceed the units height.
- (6) The model name label is attached on the lower right corner of the front panel.
- (7) Connect the Service valve with local pipe by using the pipe of the attachment. (Gas side only)
- (8) Regarding attaching the pipe of accessories, refer to an attached installation manual.

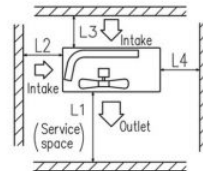
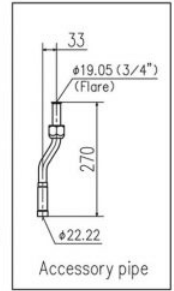
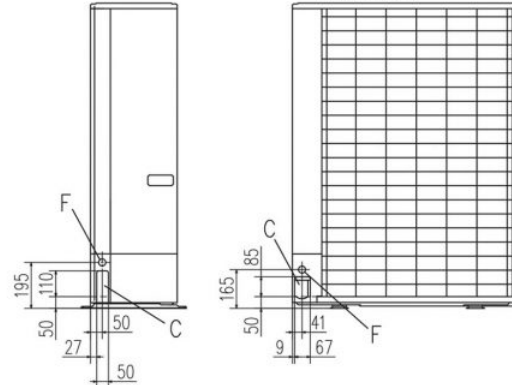
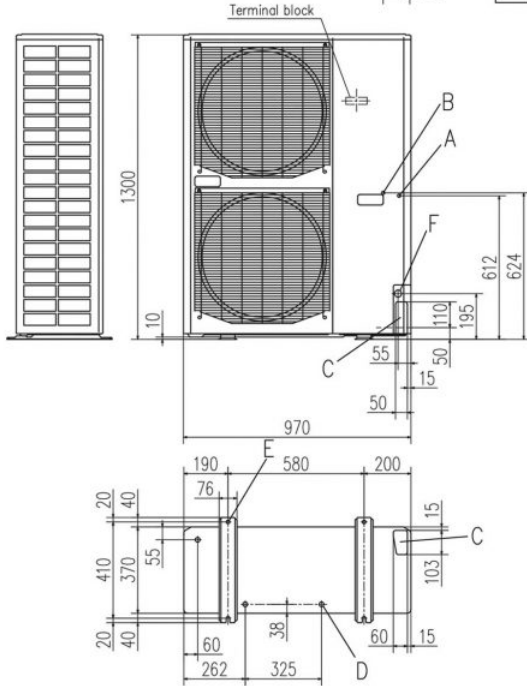

Minimum installation space

Dimensions	Examples of installation		
	I	II	III
L1	Open	Open	500
L2	300	5	Open
L3	150	300	150
L4	5	5	5

Datorită politicii de continuă îmbunătățire a produselor, ne rezervăm dreptul de a modifica specificațiile tehnice fără nicio notificare prealabilă.