



TEMPERATURE CONTROL
FOR **TODAY & TOMORROW**

MITSUBISHI
HEAVY INDUSTRIES

FDE250VSAPVH

Capacitate nominala de racire: **24.0 KW**



Poze unitate interna si unitate externa



Specificatii

Unitate internă		FDE125VH x 2	
Unitate externă		FDC250VSA	
Sursă de alimentare		Trifazic 380-415V, 50Hz / 380V, 60Hz	
Capacitate nominală de răcire (Min-Max)		kW	24.0(6.9~28.0)
Capacitate nominală de încălzire (Min-Max)		kW	27.0(5.5~31.5)
Power Consumption	Răcire/Încălzire	kW	8.52 / 7.54
EER/COP	Răcire/Încălzire	kW	2.82 / 3.58



TEMPERATURE CONTROL FOR TODAY & TOMORROW



Curent de intrare			A	5
Max. current			A	21
Nivel putere sonoră*1	U.I.*3	Răcire/Încălzire	dB(A)	64 / 64
	U.E.	Răcire/Încălzire		73 / 75
Nivel presiune sonoră*1	U.I.*3	Răcire (P-Hi/Hi/Me/Lo)		48 / 45 / 40 / 35
		Încălzire (P-Hi/Hi/Me/Lo)		48 / 45 / 40 / 35
	U.E.	Răcire/Încălzire		59 / 62
Flux de aer	U.I.*3	Răcire (P-Hi/Hi/Me/Lo)	m ³ /min	32 / 29 / 23 / 17
		Încălzire (P-Hi/Hi/Me/Lo)		32 / 29 / 23 / 17
	U.E.	Răcire/Încălzire		143 / 151
Exterior dimensions	U.I.	HeightxWidthxDepth	mm	250 x 1,620 x 690
	U.E.		mm	1,505 x 970 x 370
Greutate netă		U.I./U.E.	kg	43 / 143
Refrigerant Type GWP				R410A/2088
Ref.piping size	Lichid/Gaz		Ț,mm	12.7(1/2") / 22.22(7/8")
Lungime țeavă refrigerant (o direcție)			m	Max.70
Diferență de nivel suportată	Unitate externă este mai sus/mai jos		m	Max.30 / Max.15
Interval de funcționare - temperatură exterioară	Răcire*2		°C	-15~50
	Încălzire		°C	-15~20

Datorită politicii de continuă îmbunătățire a produselor, ne rezervăm dreptul de a modifica specificațiile tehnice fără nicio notificare prealabilă.



TEMPERATURE CONTROL FOR TODAY & TOMORROW



Filtru de aer, cantitate		Pocket plastic net x 2(lavabil)
Telecomandă (opțional)		Cu fir:RC-EX3A, RC-E5, RCH-E3 Wireless:RCN-E-E3

Schema tehnica

Models FDE100VH, 125VH, 140VH

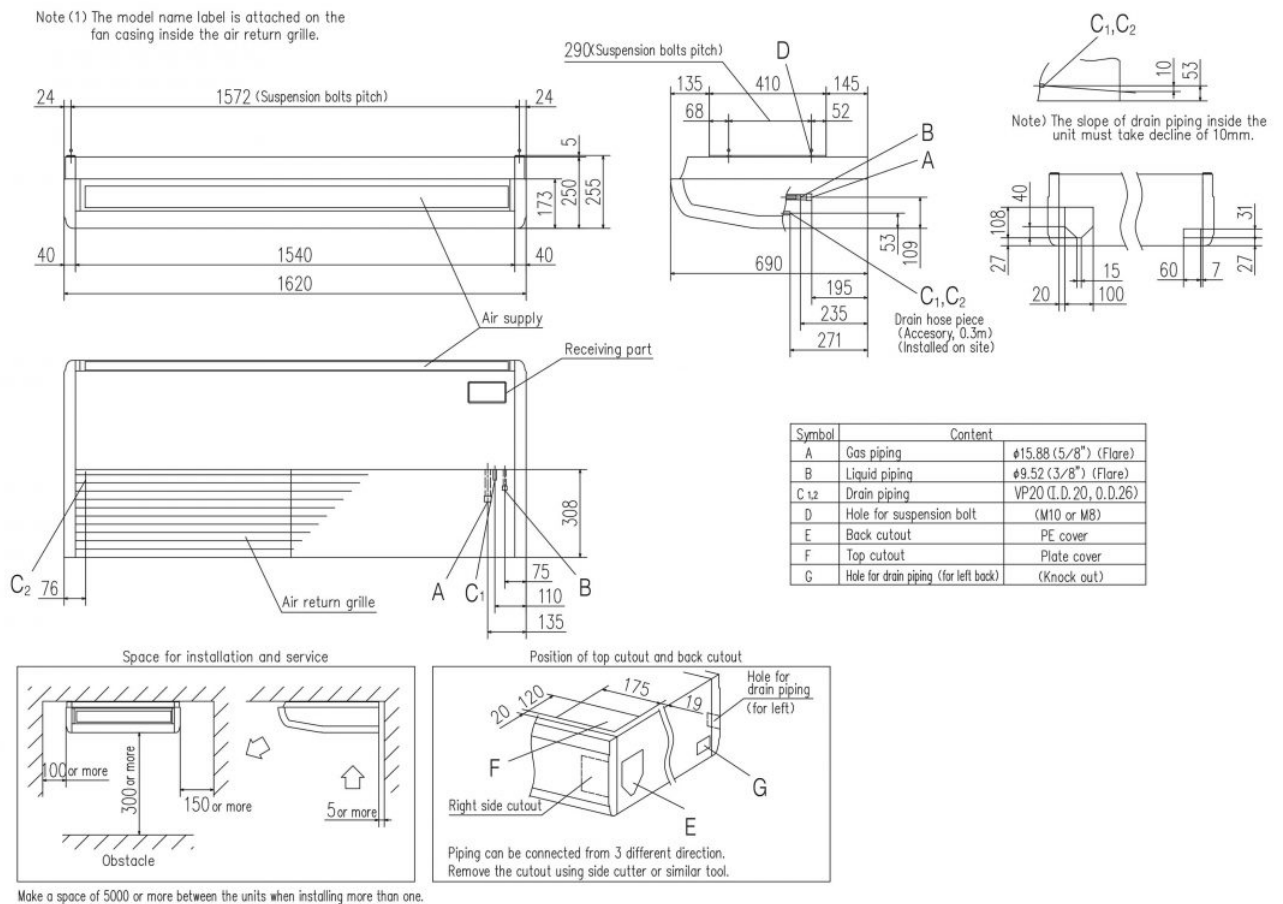

Datorită politicii de continuă îmbunătățire a produselor, ne rezervăm dreptul de a modifica specificațiile tehnice fără nicio notificare prealabilă.



TEMPERATURE CONTROL FOR TODAY & TOMORROW



FDC250VSA

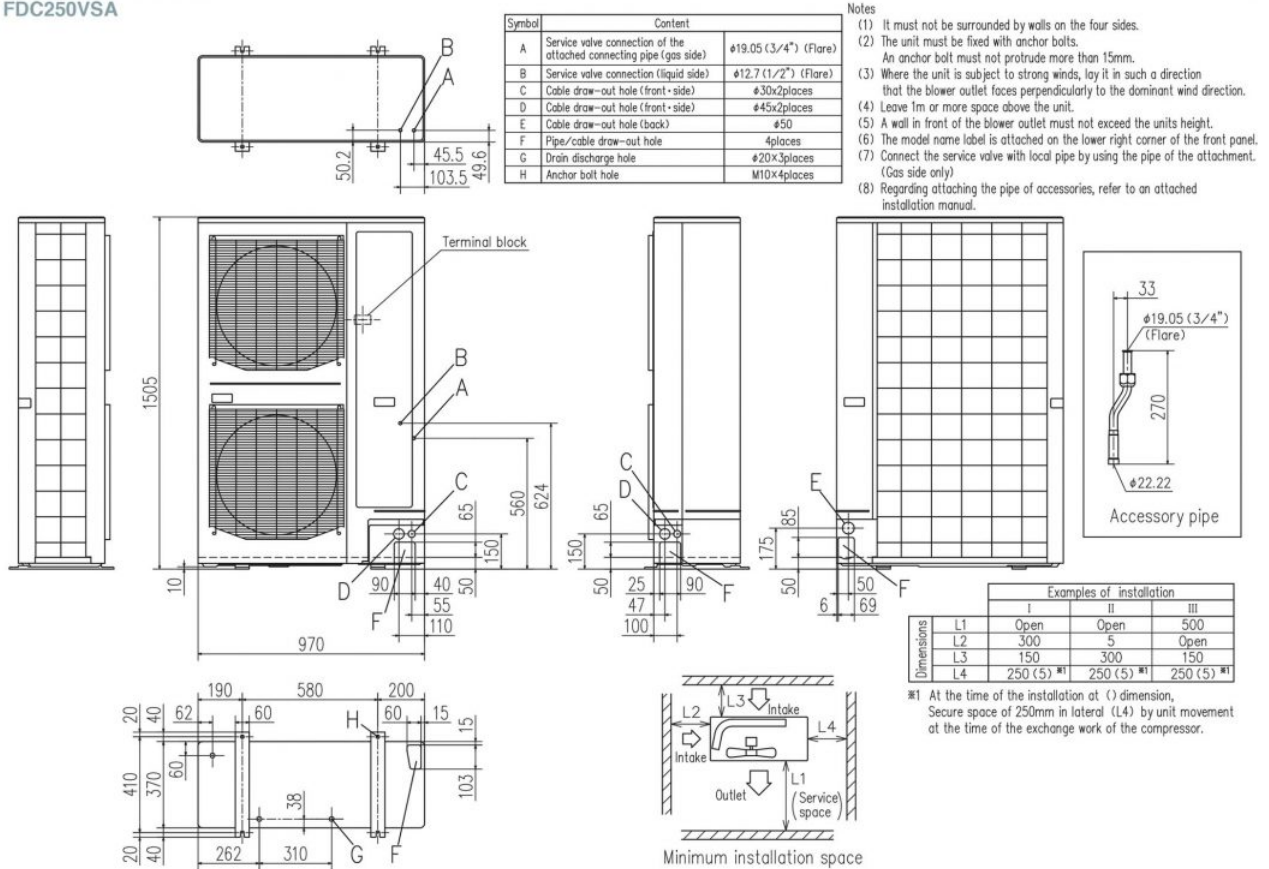

Datorită politicii de continuă îmbunătățire a produselor, ne rezervăm dreptul de a modifica specificațiile tehnice fără nicio notificare prealabilă.