



TEMPERATURE CONTROL
FOR **TODAY & TOMORROW**

mitsubishi
HEAVY INDUSTRIES

FDE50ZSXVH

Capacitate nominala de racire: **5.0 KW**



Poze unitate interna si unitate externa



Specificatii

Unitate internă		FDE50VH	
Unitate externă		SRC50ZSX-S	
Sursă de alimentare		Monofazic 220-240V, 50Hz / 220V, 60Hz	
Capacitate nominală de răcire (Min~Max)		kW	5.0 (1.1 ~ 5.6)
Capacitate nominală de încălzire (Min~Max)		kW	5.4 (0.6 ~ 6.3)
Consum de energie	Răcire/Încălzire	kW	1.52 / 1.46
EER/COP	Răcire/Încălzire		3.29 / 3.70



TEMPERATURE CONTROL FOR TODAY & TOMORROW



Curent de intrare		A	5	
Amperaj maxim		A	15	
Nivel putere sonoră*1	U.I.	Răcire/Încălzire	dB(A)	60 / 60
	U.E.	Răcire/Încălzire		63 / 63
Nivel presiune sonoră*1	U.I.	Răcire (Hi/Me/Lo/Ulo)		46 / 38 / 36 / 31
		Încălzire (Hi/Me/Lo/Ulo)		46 / 38 / 36 / 31
	U.E.	Răcire/Încălzire		50 / 49
Flux de aer	U.I.	Răcire (Hi/Me/Lo/Ulo)	m ³ /min	13 / 10 / 9 / 7
		Încălzire (Hi/Me/Lo/Ulo)		13 / 10 / 9 / 7
	U.E.	Răcire/Încălzire		40 / 33
Dimensiuni exterioare	U.I.	Înălțime / Lățime / Adâncime	mm	210 x 1,070 x 690
	U.E.			640 x 800(+71) x 290
Greutate netă	U.I. / U.E.		kg	28 / 45
Refrigerant		Tip/GWP		R410A/2088
Refrigerant		Încărcare	kg/TCO ₂ Eq	1.5/3.132
Dimensiuni țevă refrigerant		Lichid/Gaz	mm/ø	6.35(1/4") / 12.7(1/2")
Lungime țevă refrigerant (o direcție)			m	Max.30
Diferență de nivel suportată		Unitate externă este mai sus/mai jos	m	Max.20 / Max.20

Datorită politicii de continuă îmbunătățire a produselor, ne rezervăm dreptul de a modifica specificațiile tehnice fără nicio notificare prealabilă.



TEMPERATURE CONTROL FOR TODAY & TOMORROW



Interval de funcționare - temperatură exterioară	Răcire*2	°C	-15~46
	Încălzire		-20~24
Filtru de aer (cantitate)			2 x Filtre lavabile din plastic
Telecomandă (opțional)			Cu fir:RC-EX3A, RC-E5, RCH-E3 Wireless:RCN-E-E3
Clasa Energetică (Răcire/Încălzire)			A++/A
SEER			6.10
SCOP (Climat temperat)			3.92
Pdesign (răcire/încălzire(@-10°C))		kW	5.0/3.8
Consumul anual de electricitate (răcire/încălzire)		kWh/a	288/1359
Performanța pe modul încălzire			Climat temperat

Schema tehnica

Datorită politicii de continuă îmbunătățire a produselor, ne rezervăm dreptul de a modifica specificațiile tehnice fără nicio notificare prealabilă.



TEMPERATURE CONTROL FOR TODAY & TOMORROW



Models FDE40VH, 50VH

Note (1) The model name label is attached on the fan casing inside the air return grille.

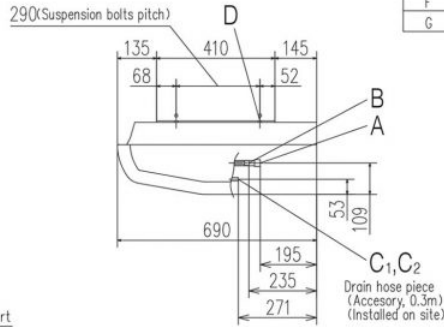
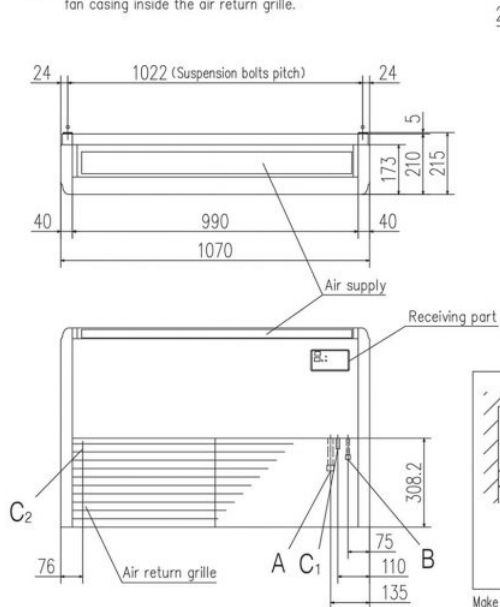

Symbol	Content	
A	Gas piping	φ12.7 (1/2") (Flare)
B	Liquid piping	φ6.35 (1/4") (Flare)
C 1,2	Drain piping	VP20 (I.D.20, O.D.26)
D	Hole for suspension bolts	(M10 or M8)
E	Back cutout	PE cover
F	Top cutout	Plate cover
G	Drain piping (for left back)	(Knock out)

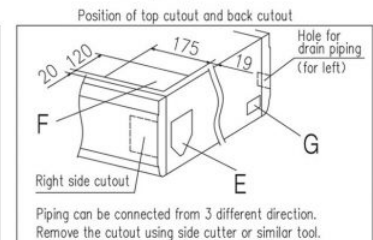
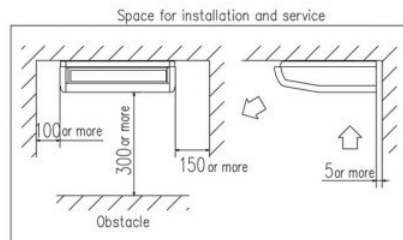
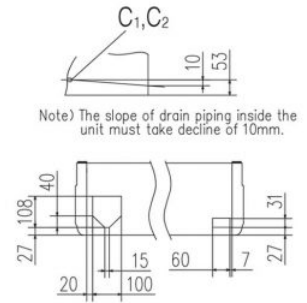

Make a space of 4000 or more between the units when installing more than one.

Datorită politicii de continuă îmbunătățire a produselor, ne rezervăm dreptul de a modifica specificațiile tehnice fără nicio notificare prealabilă.



TEMPERATURE CONTROL FOR TODAY & TOMORROW



SRC40ZSX-W1, 50ZSX-W1, 60ZSX-W1 SRC40ZSX-S, 50ZSX-S, 60ZSX-S

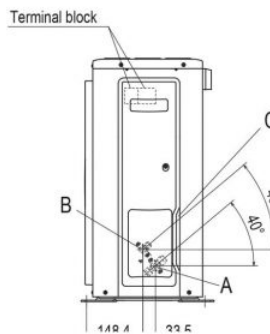
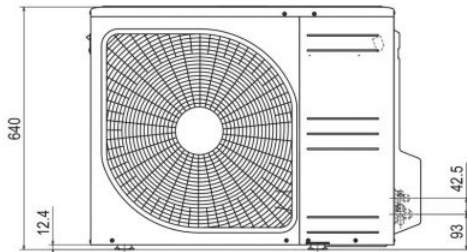
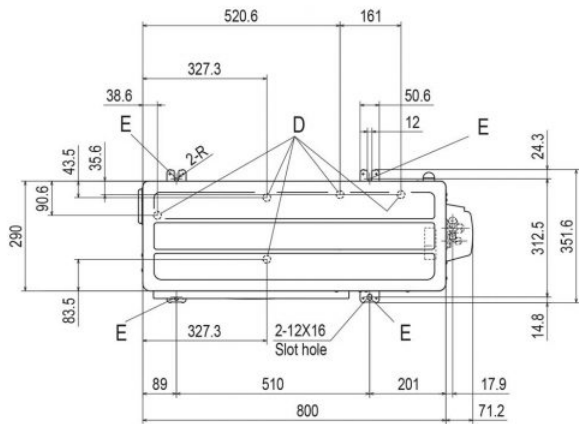

Symbol	Content	
A	Service valve connection (Gas side)	$\phi 12.7(1/2)$ (Flare)
B	Service valve connection (Liquid side)	$\phi 6.35(1/4)$ (Flare)
C	Pipe/cable draw-out hole	
D	Drain discharge hole	$\phi 20 \times 5$ places
E	Anchor bolt hole	M10-12 \times 4 places

Notes

- (1) The unit must not be surrounded by walls on the four sides.
- (2) The unit must be fixed with anchor bolts. An anchor bolt must not protrude more than 15mm.
- (3) If the unit is installed in the location where there is a possibility of strong winds, place the unit such that the direction of air from the outlet gets perpendicular to the wind direction.
- (4) Leave 200mm or more space above the unit.
- (5) The wall height on the outlet side should be 1200mm or less.
- (6) The model name label is attached on the front side of the unit.

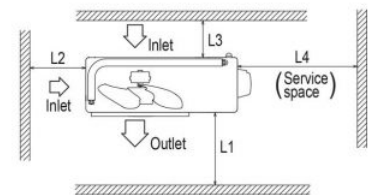

Minimum installation space

Examples installation Size	Minimum installation space			
	I	II	III	IV
L1	Open	280	280	180
L2	100	75	Open	Open
L3	100	80	80	80
L4	250	Open	250	Open

Datorită politicii de continuă îmbunătățire a produselor, ne rezervăm dreptul de a modifica specificațiile tehnice fără nicio notificare prealabilă.