



TEMPERATURE CONTROL
FOR **TODAY & TOMORROW**

MITSUBISHI
HEAVY INDUSTRIES

FDE71VNXPVH

Capacitate nominala de racire: **7.1 KW**



Poze unitate interna si unitate externa



Specificatii

Unitate internă		FDE40VH x 2	
Unitate externă		FDC71VNX	
Sursă de alimentare		Monofazic 220-240V, 50Hz / 220V, 60Hz	
Capacitate nominală de răcire (Min-Max)		kW	7.1 (3.2 ~ 8.0)
Capacitate nominală de încălzire (Min-Max)		kW	8.0 (3.6 ~ 9.0)
Power Consumption	Răcire/Încălzire	kW	2.05 / 2.35
EER/COP	Răcire/Încălzire	kW	3.46 / 3.40



TEMPERATURE CONTROL FOR TODAY & TOMORROW



Curent de intrare			A	5
Max. current			A	17
Nivel putere sonoră*1	U.I.*3	Răcire/Încălzire	dB(A)	60 / 60
	U.E.	Răcire/Încălzire		66 / 66
Nivel presiune sonoră*1	U.I.*3	Răcire (P-Hi/Hi/Me/Lo)		46 / 38 / 36 / 31
		Încălzire (P-Hi/Hi/Me/Lo)		46 / 38 / 36 / 31
	U.E.	Răcire/Încălzire		51 / 48
Flux de aer	U.I.*3	Răcire (P-Hi/Hi/Me/Lo)	m ³ /min	13 / 10 / 9 / 7
		Încălzire (P-Hi/Hi/Me/Lo)		13 / 10 / 9 / 7
	U.E.	Răcire/Încălzire		60 / 50
Exterior dimensions	U.I.	HeightxWidthxDepth	mm	210 x 1,070 x 690
	U.E.		mm	750 x 880(+88) x 340
Greutate netă		U.I./U.E.	kg	28 / 60
Refrigerant charge			kg/TCO ₂ E	2.95/6.160
Refrigerant Type GWP				R410A/2088
Ref.piping size	Lichid/Gaz		Ț, mm	9.52(3/8") / 15.88(5/8")
Lungime țeavă refrigerant (o direcție)			m	Max. 50
Diferență de nivel suportată	Unitate externă este mai sus/mai jos		m	Max.30 / Max.15
Interval de funcționare - temperatură exterioară		Răcire*2	°C	-15~43

Datorită politicii de continuă îmbunătățire a produselor, ne rezervăm dreptul de a modifica specificațiile tehnice fără nicio notificare prealabilă.



TEMPERATURE CONTROL FOR TODAY & TOMORROW



Încălzire	°C	-20~20	
Filtru de aer, cantitate			Pocket plastic net x2(lavabil)
Telecomandă (opțional)			Cu fir:RC-EX3A, RC-E5, RCH-E3 Wireless:RCN- E-E3
Clasa Energetică (Răcire/Încălzire)			A/A+
SEER			5.26
SCOP (Climat temperat)			4.09
Pdesign (răcire/încălzire(@-10°C))			7.1/6.0
Annual Electricity Consumption			473/2056
Performanța pe modul încălzire			Climat temperat

Schema tehnica

Datorită politicii de continuă îmbunătățire a produselor, ne rezervăm dreptul de a modifica specificațiile tehnice fără nicio notificare prealabilă.



TEMPERATURE CONTROL FOR TODAY & TOMORROW



Models FDE40VH, 50VH

Note (1) The model name label is attached on the fan casing inside the air return grille.

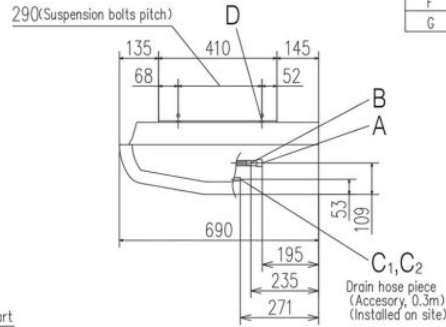
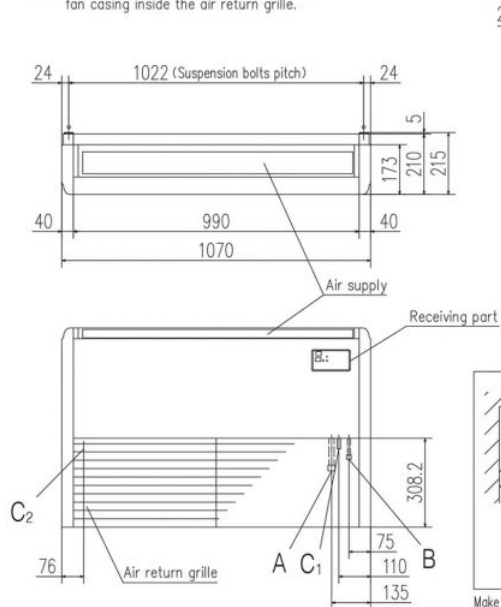

Symbol	Content	
A	Gas piping	φ12.7 (1/2") (Flare)
B	Liquid piping	φ6.35 (1/4") (Flare)
C 1,2	Drain piping	VP20 (I.D.20, O.D.26)
D	Hole for suspension bolts	(M10 or M8)
E	Back cutout	PE cover
F	Top cutout	Plate cover
G	Drain piping (for left back)	(Knock out)

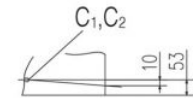

Note) The slope of drain piping inside the unit must take decline of 10mm.

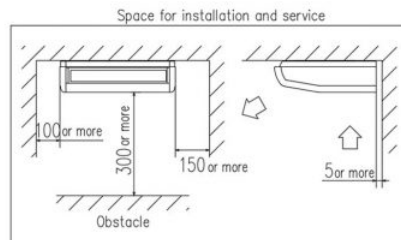
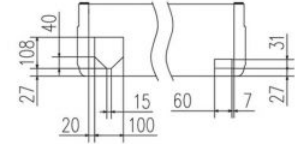

Make a space of 4000 or more between the units when installing more than one.

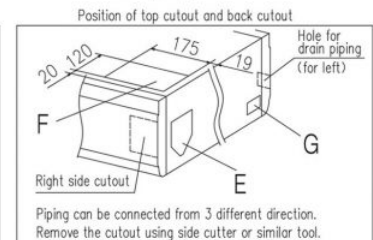

Datorită politicii de continuă îmbunătățire a produselor, ne rezervăm dreptul de a modifica specificațiile tehnice fără nicio notificare prealabilă.



TEMPERATURE CONTROL FOR TODAY & TOMORROW



FDC71VNX

Symbol	Content	
A	Service valve connection (gas side)	φ15.88 (5/8") (Flare)
B	Service valve connection (liquid side)	φ9.52 (3/8") (Flare)
C	Pipe/cable draw-out hole	
D	Drain discharge hole	φ20 × 3places
E	Anchor bolt hole	M10 × 4places

Notes

- (1) It must not be surrounded by walls on the four sides.
- (2) The unit must be fixed with anchor bolts. An anchor bolt must not protrude more than 15mm.
- (3) Where the unit is subject to strong winds, lay it in such a direction that the blower outlet faces perpendicularly to the dominant wind direction.
- (4) Leave 1m or more space above the unit.
- (5) A wall in front of the blower outlet must not exceed the units height.
- (6) The model name label is attached on the lower right corner of the front panel.

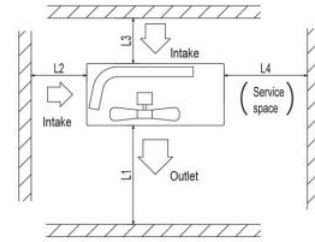
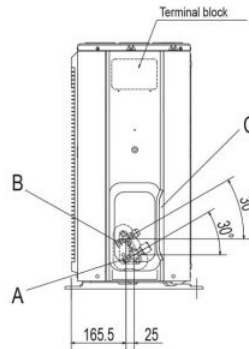
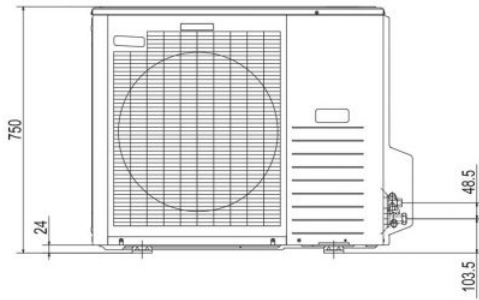
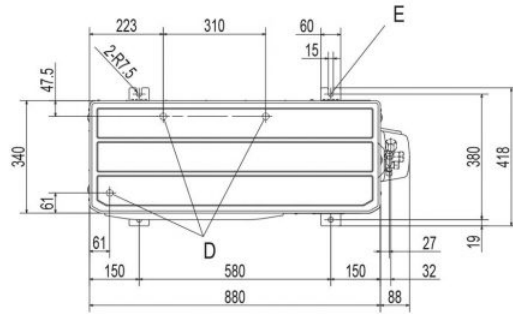

Minimum installation space

Examples of Dimensions	I	II	III
L1	Open	Open	500
L2	300	250	Open
L3	100	150	100
L4	250	250	250

Datorită politicii de continuă îmbunătățire a produselor, ne rezervăm dreptul de a modifica specificațiile tehnice fără nicio notificare prealabilă.