



TEMPERATURE CONTROL  
FOR **TODAY & TOMORROW**

  
**MITSUBISHI**  
**HEAVY INDUSTRIES**

## FDT100VNA VH

Capacitate nominala de racire: **10.0 KW**



## Poze unitate interna si unitate externa



## Specificatii

Unitate internă		FDT100VH	
Unitate externă		FDC100VNA	
Sursă de alimentare		Monofazic 220-240V, 50Hz / 220V, 60Hz	
Capacitate nominală de răcire (Min~Max)		kW	10.0 ( 4.0 ~ 11.2 )
Capacitate nominala de incalzire (Min~Max)		kW	11.2 ( 4.0 ~ 12.5 )
Consumul de energie	Racire/Incalzire	kW	2.73 / 2.64
EER/COP	Racire/Incalzire		3.66 / 4.26



## TEMPERATURE CONTROL FOR TODAY & TOMORROW



Curent de intrare			A	5
Amperaj maxim			A	24
Nivel putere sonoră*1	U.I.	Racire/Incalzire	dB(A)	62 / 62
	U.E.	Racire/Incalzire		70 / 70
Nivel presiune sonoră*1	U.I.	Racire (Hi/Me/Lo/Ulo)		47 / 39 / 36 / 30
		Incalzire (Hi/Me/Lo/Ulo)	47 / 39 / 36 / 29	
	U.E.	Racire/Incalzire	54 / 56	
Flux de aer	U.I.	Racire (Hi/Me/Lo/Ulo)	m <sup>3</sup> /min	37 / 26 / 23 / 17
		Incalzire (Hi/Me/Lo/Ulo)		37 / 26 / 23 / 17
	U.E.	Racire/Incalzire		75 / 73
Dimensiuni exterioare	U.I.	Inaltime x Latime x Adancime	mm	Unitate: 298 x 840 x 840 Panou: 35 x 950 x 950
	U.E.			
Greutate netă	U.E. U.I. / U.E.		kg	845 x 970 x 370 30 (Unitate:25 Panou standard:5) / 80
Refrigerant		Tip/GWP		R410A/2088
Refrigerant		Incarcare	kg/TCO <sub>2</sub> Eq	3.8/7.934
Dimensiuni țevă refrigerant		Lichid/Gaz	ø mm	9.52(3/8") / 15.88(5/8")
Lungime teava refrigerant (o directie)			m	Max.50
Diferenta de nivel suportata		Unitate externă este mai sus/mai jos	m	Max.50 / Max.15

**Datorită politicii de continuă îmbunătățire a produselor, ne rezervăm dreptul de a modifica specificațiile tehnice fără nicio notificare prealabilă.**



## TEMPERATURE CONTROL FOR TODAY & TOMORROW



Interval de functionare - temperatura exterioara	Racire*2	°C	-15~50
	Incalzire		-20~20
Panou			T-PSA-5BW-E, T-PSAE-5BW-E (Alb) / T-PSA-5BB-E, T-PSAE-5BB-E (Negru)
Filtru de aer			Filtru lavabil x 1(Lavabil)
Telecomanda (opționalal)			Cu fir: RC-EX3A, RC-E5, RCH-E3 Fara fir: RCN-T-5BW-E2, RCN-T-5BB-E2
Clasa energetica (Racire/Incalzire)			A++/A+
SEER			6.78
SCOP (Climat temperat)			4.52
Pdesign (racire/incalzire(@-10°C))		kW	10.0/8.5
Consumul anual de electricitate (racire/incalzire)		kWh/a	516/2633
Performanta in modul Incalzire			Medie

## Schema tehnica

---

**Datorită politicii de continuă îmbunătățire a produselor, ne rezervăm dreptul de a modifica specificațiile tehnice fără nicio notificare prealabilă.**



# TEMPERATURE CONTROL FOR TODAY & TOMORROW



Models FDT100VH, 125VH, 140VH

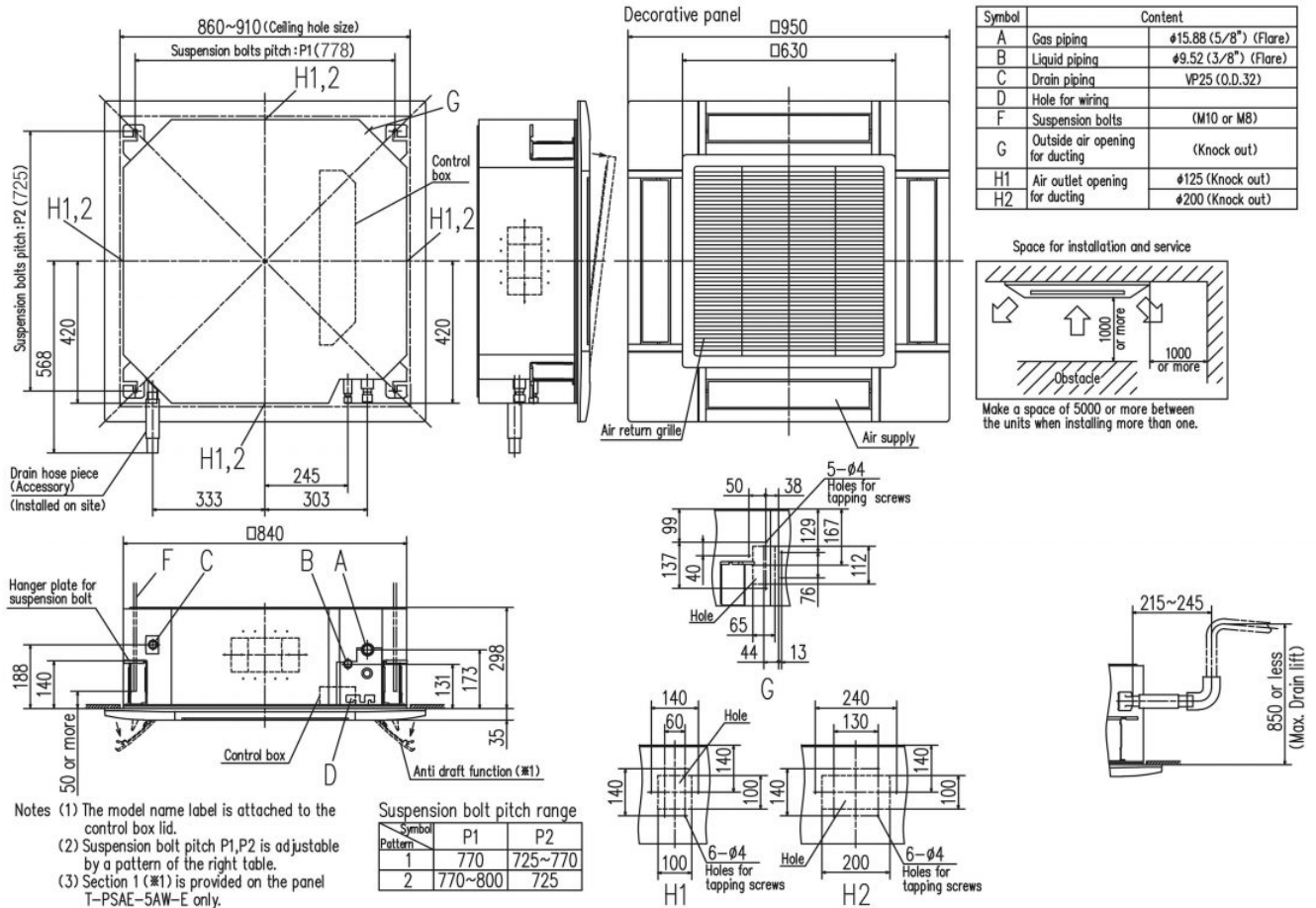

**Datorită politicii de continuă îmbunătățire a produselor, ne rezervăm dreptul de a modifica specificațiile tehnice fără nicio notificare prealabilă.**



# TEMPERATURE CONTROL FOR TODAY & TOMORROW



FDC100VNA, 125VNA, 140VNA  
100VSA, 125VSA, 140VSA

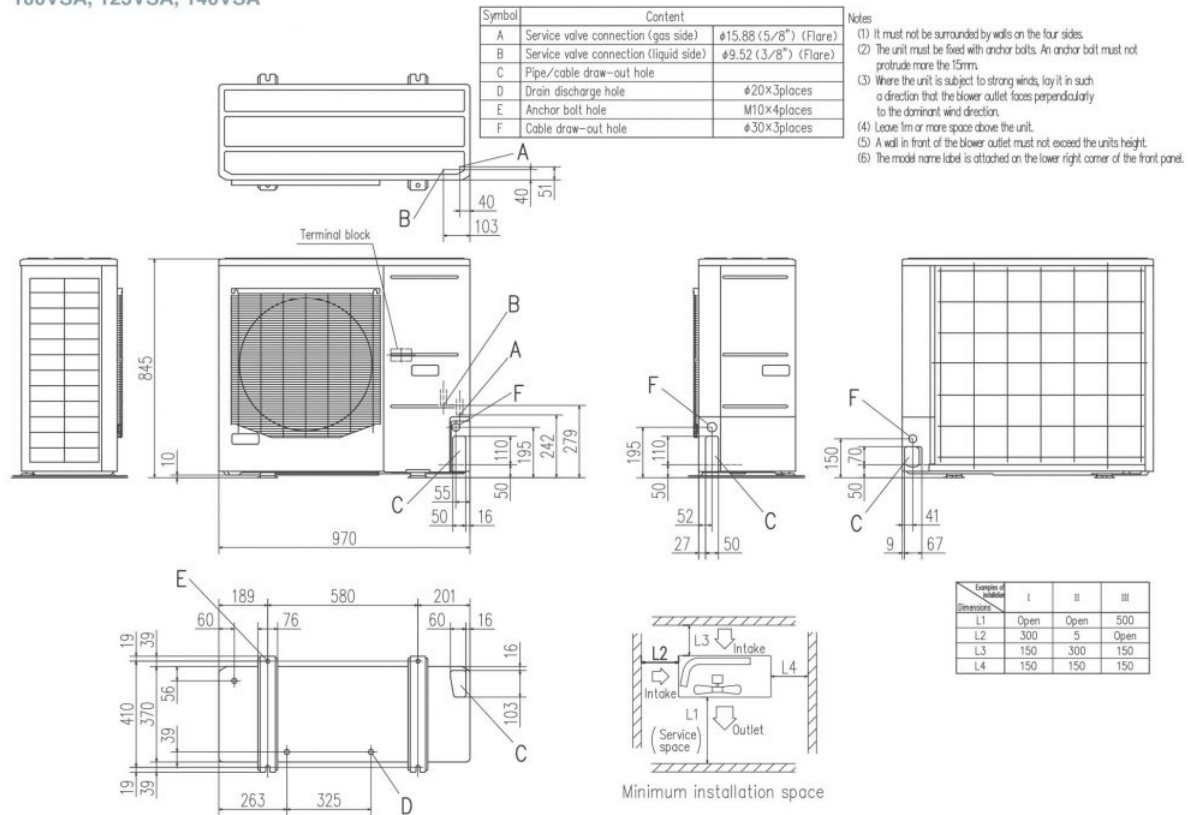

**Datorită politicii de continuă îmbunătățire a produselor, ne rezervăm dreptul de a modifica specificațiile tehnice fără nicio notificare prealabilă.**