



TEMPERATURE CONTROL  
FOR TODAY & TOMORROW

  
**MITSUBISHI**  
**HEAVY INDUSTRIES**

## FDT100VNXWPVH

Capacitate nominala de racire: **10.0 KW**



## Poze unitate interna si unitate externa



## Specificatii

Unitate internă		FDT50VH x 2	
Unitate externă		FDC100VNX-W	
Sursă de alimentare		Monofazic 220-240V, 50Hz / 220V, 60Hz	
Capacitate nominală de răcire (Min-Max)		kW	10.0 ( 3.5 ~ 11.2 )
Capacitate nominală de încălzire (Min-Max)		kW	11.2 ( 2.7 ~ 12.5 )
Power Consumption	Răcire/Încălzire	kW	2.30 / 2.64
EER/COP	Răcire/Încălzire	kW	4.35 / 4.25



## TEMPERATURE CONTROL FOR TODAY & TOMORROW



Curent de intrare			A	5
Max. current			A	25
Nivel putere sonoră*1	U.I.*3	Răcire/Încălzire	dB(A)	55 / 56
	U.E.	Răcire/Încălzire		67 / 67
Nivel presiune sonoră*1	U.I.*3	Răcire (P-Hi/Hi/Me/Lo)		41 / 33 / 30 / 26
		Încălzire (P-Hi/Hi/Me/Lo)		42 / 33 / 28 / 20
	U.E.	Răcire/Încălzire		53 / 51
Flux de aer	U.I.*3	Răcire (P-Hi/Hi/Me/Lo)	m <sup>3</sup> /min	22 / 16 / 13 / 10
		Încălzire (P-Hi/Hi/Me/Lo)		22 / 16 / 13 / 10
	U.E.	Răcire/Încălzire		100 / 100
Exterior dimensions	U.I.	HeightxWidthxDepth	mm	Unitate: 236 x 840 x 840 Panou: 35 x 950 x 950
	U.E.			
Greutate netă	U.E.	U.I./U.E.	mm kg	1,300 x 970 x 370 24(Unitate:19 Panou standard:5) / 97
Refrigerant charge			kg/TCO <sub>2</sub> E	4.0/2.7
Refrigerant Type GWP				R32/675
Ref.piping size	Lichid/Gaz		Ț, mm	9.52(3/8") / 15.88(5/8")
Lungime țeavă refrigerant (o direcție)			m	Max. 100
Diferență de nivel suportată	Unitate externă este mai sus/mai jos		m	Max.50 / Max.15

**Datorită politicii de continuă îmbunătățire a produselor, ne rezervăm dreptul de a modifica specificațiile tehnice fără nicio notificare prealabilă.**



## TEMPERATURE CONTROL FOR TODAY & TOMORROW



Interval de funcționare - temperatură exterioară	Răcire*2	°C	-15~50
	Încălzire	°C	-20~20
Panou			White: T-PSA-5BW-E, T-PSAE-5BW-E / Black: T-PSA-5BB-E, T-PSAE-5BB-E
Filtru de aer, cantitate			Filtru lavabil din plastic x 1 (Lavabil)
Telecomandă (opțional)			Cu fir: RC-EX3A, RC-E5, RCH-E3 Wireless: RCN-T-5BW-E2, RCN-T-5BB-E2
Clasa Energetică (Răcire/Încălzire)			A++/A+
SEER			8.24
SCOP (Climat temperat)			4.24
Pdesign (răcire/încălzire(@-10°C))			10.0/11.2
Annual Electricity Consumption			425/3700
Performanța pe modul încălzire			Climat temperat

## Schema tehnica

---

**Datorită politicii de continuă îmbunătățire a produselor, ne rezervăm dreptul de a modifica specificațiile tehnice fără nicio notificare prealabilă.**



# TEMPERATURE CONTROL FOR TODAY & TOMORROW



Models FDT40VH, 50VH, 60VH, 71VH

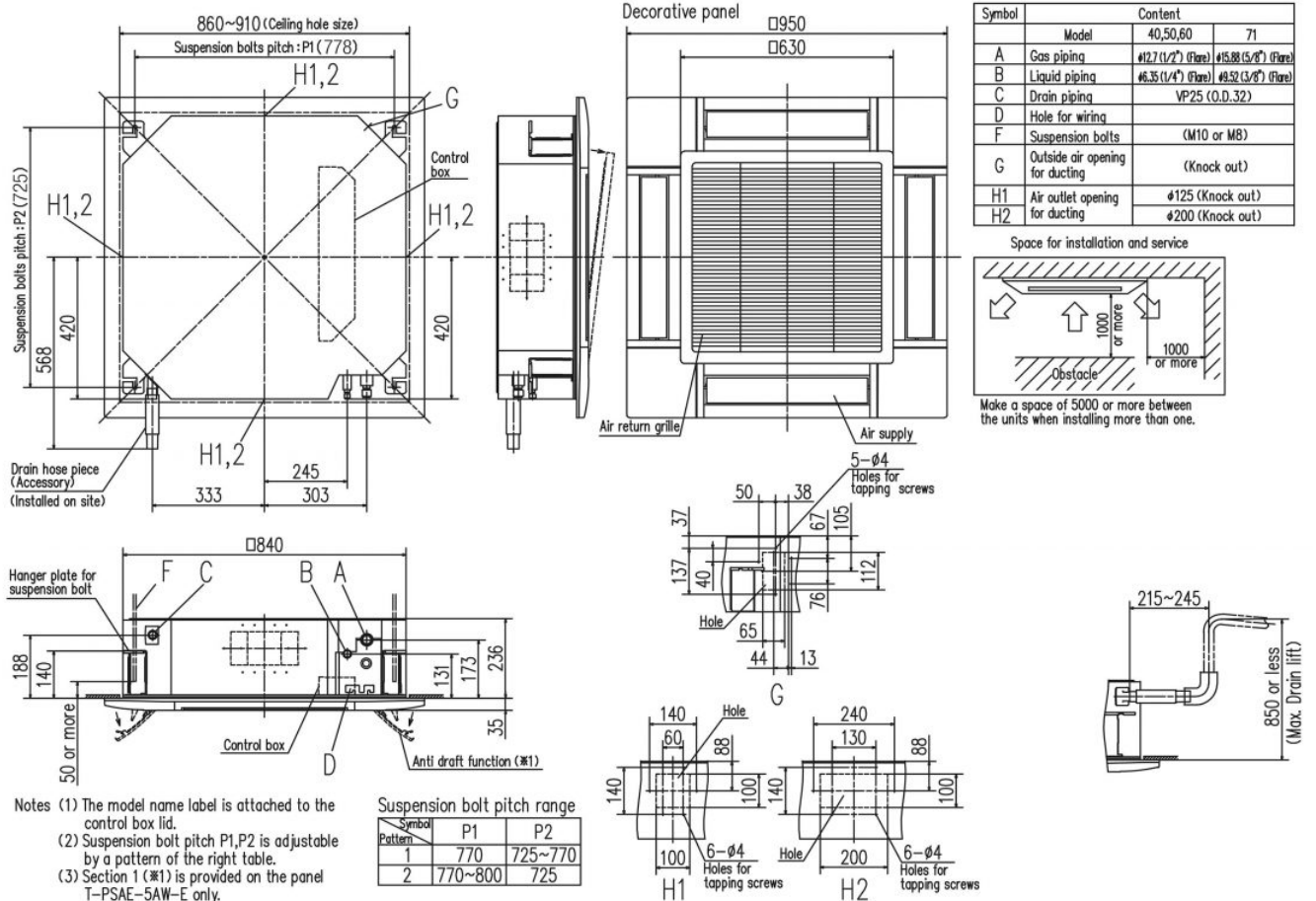

- Notes (1) The model name label is attached to the control box lid.  
 (2) Suspension bolt pitch P1,P2 is adjustable by a pattern of the right table.  
 (3) Section 1 (※1) is provided on the panel T-PSAE-5AW-E only.

Symbol	Pattern	P1	P2
1		770	725~770
2		770~800	725

**Datorită politicii de continuă îmbunătățire a produselor, ne rezervăm dreptul de a modifica specificațiile tehnice fără nicio notificare prealabilă.**



# TEMPERATURE CONTROL FOR TODAY & TOMORROW



FDC100VN-X-W, 125VN-X-W, 140VN-X-W, 100VS-X-W, 125VS-X-W, 140VS-X-W

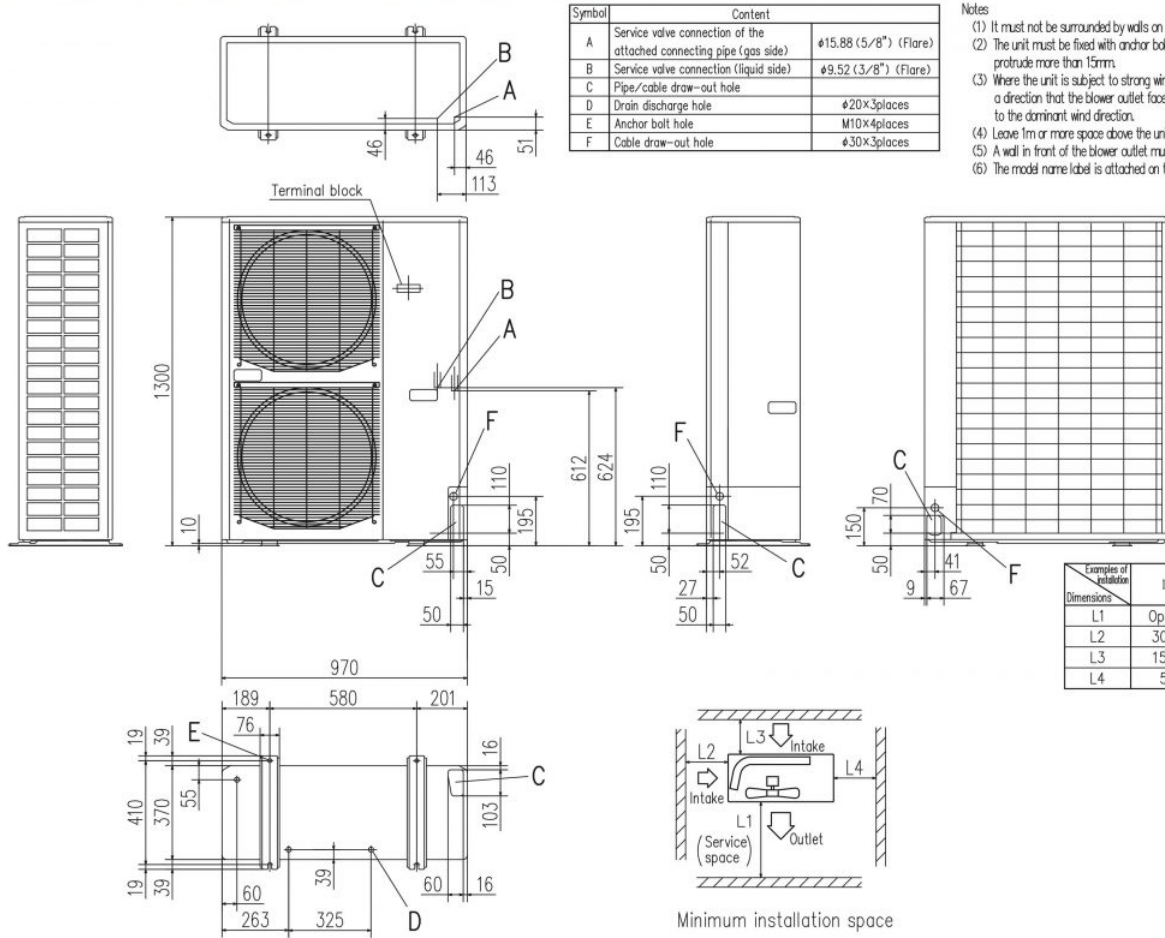

- Notes
- (1) It must not be surrounded by walls on the four sides.
  - (2) The unit must be fixed with anchor bolts. An anchor bolt must not protrude more than 15mm.
  - (3) Where the unit is subject to strong winds, lay it in such a direction that the blower outlet faces perpendicularly to the dominant wind direction.
  - (4) Leave 1m or more space above the unit.
  - (5) A wall in front of the blower outlet must not exceed the units height.
  - (6) The model name label is attached on the lower right corner of the front panel.

**Datorită politicii de continuă îmbunătățire a produselor, ne rezervăm dreptul de a modifica specificațiile tehnice fără nicio notificare prealabilă.**