



TEMPERATURE CONTROL  
FOR **TODAY & TOMORROW**

  
**MITSUBISHI**  
**HEAVY INDUSTRIES**

## FDT100VNXWVH

Capacitate nominala de racire: **10.0 KW**



## Poze unitate interna si unitate externa



## Specificatii

Unitate internă		FDT100VH	
Unitate externă		FDC100VNX-W	
Sursă de alimentare		Monofazic 220-240V, 50Hz / 220V, 60Hz	
Capacitate nominală de răcire (Min~Max)		kW	10.0 ( 3.5 ~ 11.2 )
Capacitate nominala de incalzire (Min~Max)		kW	11.2 ( 2.7 ~ 12.5 )
Consumul de energie	Racire/Incalzire	kW	2.28 / 2.48
EER/COP	Racire/Incalzire		4.38 / 4.52



## TEMPERATURE CONTROL FOR TODAY & TOMORROW



Curent de intrare		A	5	
Amperaj maxim		A	25	
Nivel putere sonoră*1	U.I.	Racire/Incalzire	dB(A)	62 / 62
	U.E.	Racire/Incalzire		67 / 67
Nivel presiune sonoră*1	U.I.	Racire (Hi/Me/Lo/Ulo)		47 / 39 / 36 / 30
		Incalzire (Hi/Me/Lo/Ulo)		47 / 39 / 36 / 29
	U.E.	Racire/Incalzire		53 / 51
Flux de aer	U.I.	Racire (Hi/Me/Lo/Ulo)	m <sup>3</sup> /min	37 / 26 / 23 / 17
		Incalzire (Hi/Me/Lo/Ulo)		37 / 26 / 23 / 17
	U.E.	Racire/Incalzire		100 / 100
Dimensiuni exterioare	U.I.	Inaltime x Latime x Adancime	mm	Unitate: 298 x 840 x 840 Panou: 35 x 950 x 950
	U.E.			
Greutate netă	U.E. U.I. / U.E.		kg	1,300 x 970 x 370 30 (Unitate:25 Panou standard:5) / 97
Refrigerant		Tip/GWP		R32/675
Refrigerant		Incarcare	kg/TCO <sub>2</sub> Eq	4.0/2.7
Dimensiuni țevă refrigerant		Lichid/Gaz	ø mm	9.52(3/8") / 15.88(5/8")
Lungime teava refrigerant (o directie)			m	Max.100
Diferenta de nivel suportata		Unitate externă este mai sus/mai jos	m	Max.50 / Max.15

**Datorită politicii de continuă îmbunătățire a produselor, ne rezervăm dreptul de a modifica specificațiile tehnice fără nicio notificare prealabilă.**



## TEMPERATURE CONTROL FOR TODAY & TOMORROW



Interval de functionare - temperatura exterioara	Racire*2	°C	-15~50
	Incalzire		-20~20
Panou			T-PSA-5BW-E, T-PSAE-5BW-E (Alb) / T-PSA-5BB-E, T-PSAE-5BB-E (Negru)
Filtru de aer			Filtru lavabil x 1(Lavabil)
Telecomanda (opționalal)			Cu fir: RC-EX3A, RC-E5, RCH-E3 Fara fir: RCN-T-5BW-E2, RCN-T-5BB-E2
Clasa energetica (Racire/Incalzire)			A++/A+
SEER			8.00
SCOP (Climat temperat)			4.44
Pdesign (racire/incalzire(@-10°C))		kW	10.0/11.2
Consumul anual de electricitate (racire/incalzire)		kWh/a	438/3534
Performanta in modul Incalzire			Medie

## Schema tehnica

---

**Datorită politicii de continuă îmbunătățire a produselor, ne rezervăm dreptul de a modifica specificațiile tehnice fără nicio notificare prealabilă.**



# TEMPERATURE CONTROL FOR TODAY & TOMORROW



Models FDT100VH, 125VH, 140VH

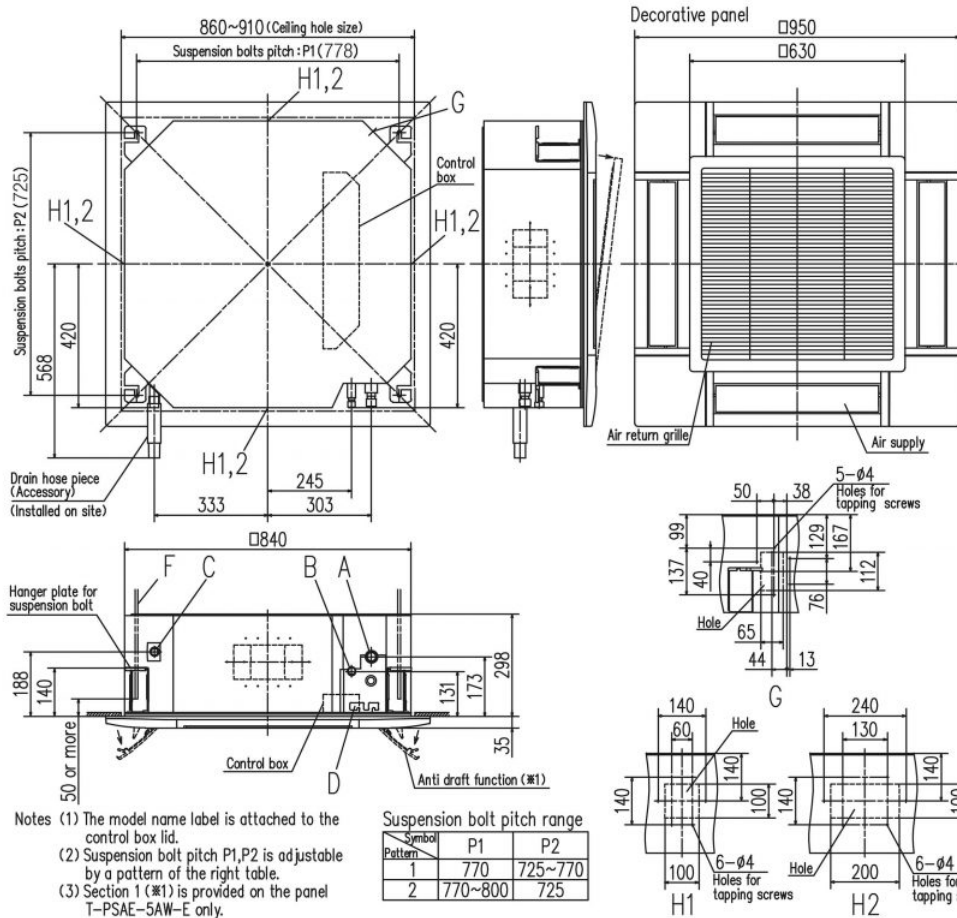

Symbol	Content
A	Gas piping #15.88 (5/8") (Flare)
B	Liquid piping #9.52 (3/8") (Flare)
C	Drain piping VP25 (O.D.32)
D	Hole for wiring
F	Suspension bolts (M10 or M8)
G	Outside air opening for ducting (Knock out)
H1	Air outlet opening for ducting #125 (Knock out)
H2	Air outlet opening for ducting #200 (Knock out)

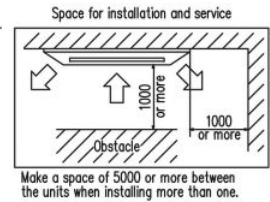

- Notes (1) The model name label is attached to the control box lid.  
 (2) Suspension bolt pitch P1,P2 is adjustable by a pattern of the right table.  
 (3) Section 1 (※1) is provided on the panel T-PSAE-5AW-E only.

Symbol	Suspension bolt pitch range	
Pattern	P1	P2
1	770	725~770
2	770~800	725

**Datorită politicii de continuă îmbunătățire a produselor, ne rezervăm dreptul de a modifica specificațiile tehnice fără nicio notificare prealabilă.**



# TEMPERATURE CONTROL FOR TODAY & TOMORROW



FDC100VN-X-W, 125VN-X-W, 140VN-X-W, 100VS-X-W, 125VS-X-W, 140VS-X-W

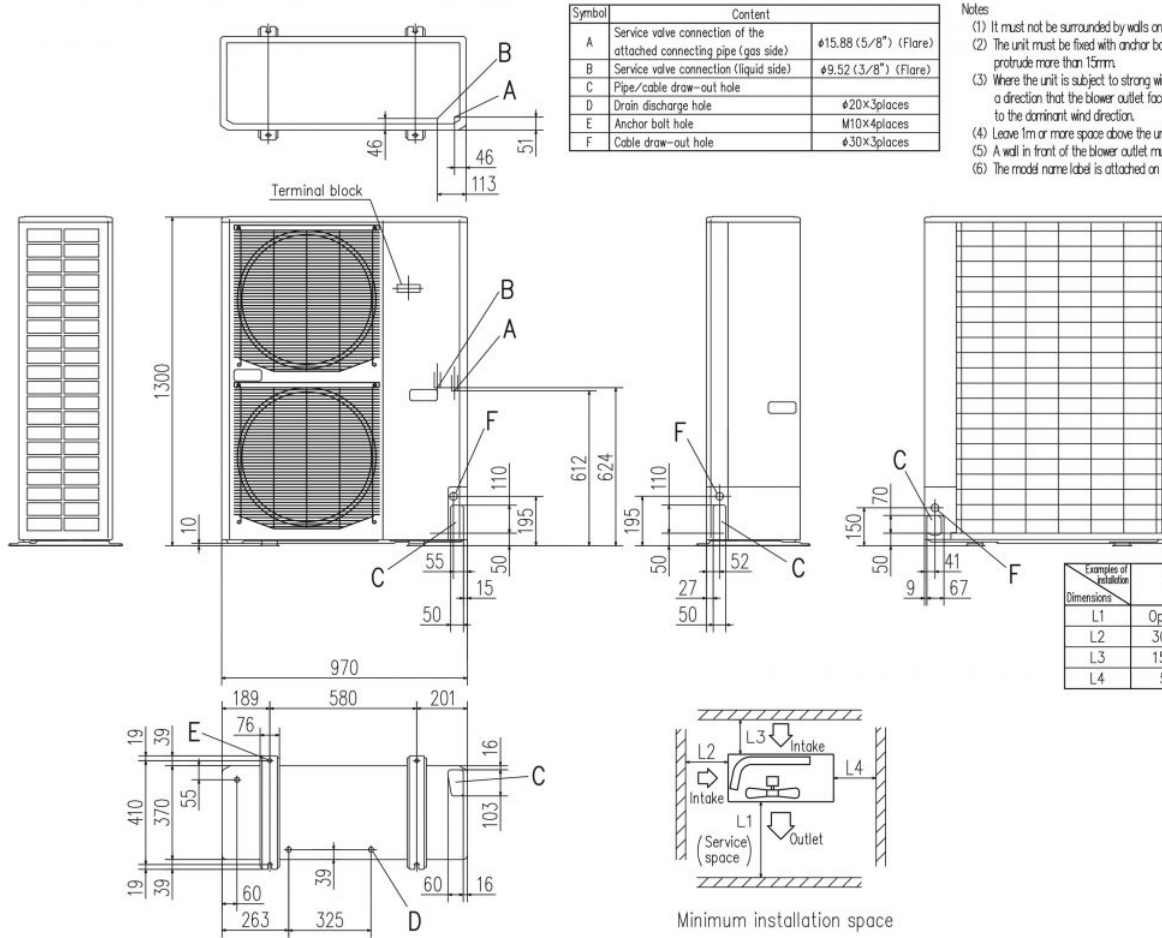

- Notes
- (1) It must not be surrounded by walls on the four sides.
  - (2) The unit must be fixed with anchor bolts. An anchor bolt must not protrude more than 15mm.
  - (3) Where the unit is subject to strong winds, lay it in such a direction that the blower outlet faces perpendicularly to the dominant wind direction.
  - (4) Leave 1m or more space above the unit.
  - (5) A wall in front of the blower outlet must not exceed the units height.
  - (6) The model name label is attached on the lower right corner of the front panel.

Minimum installation space

**Datorită politicii de continuă îmbunătățire a produselor, ne rezervăm dreptul de a modifica specificațiile tehnice fără nicio notificare prealabilă.**