



TEMPERATURE CONTROL
FOR TODAY & TOMORROW



mitsubishi
HEAVY INDUSTRIES

FDT125VNXWPVH

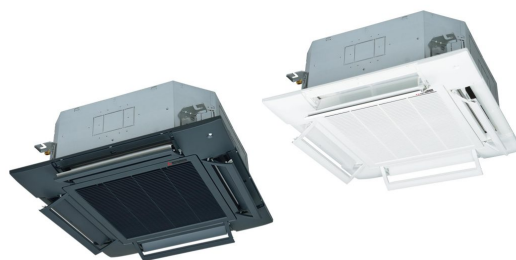
Capacitate nominala de racire: **12.5 KW**

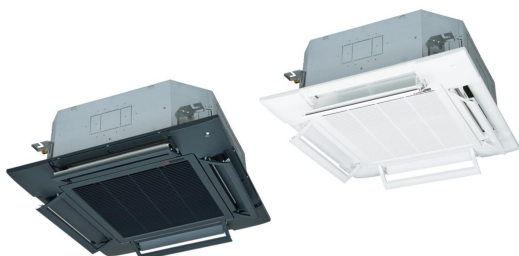

Poze unitate interna si unitate externa



Specificatii

Unitate internă		FDT60VH x 2	
Unitate externă		FDC125VNX-W	
Sursă de alimentare		Monofazic 220-240V, 50Hz / 220V, 60Hz	
Capacitate nominală de răcire (Min-Max)		kW	12.5 (3.5 ~ 14.0)
Capacitate nominală de încălzire (Min-Max)		kW	14.0 (2.7 ~ 17.0)
Power Consumption	Răcire/Încălzire	kW	2.98 / 3.03
EER/COP	Răcire/Încălzire	kW	4.19 / 4.62



TEMPERATURE CONTROL FOR TODAY & TOMORROW



Curent de intrare			A	5
Max. current			A	27
Nivel putere sonoră*1	U.I.*3	Răcire/Încălzire	dB(A)	58 / 59
	U.E.	Răcire/Încălzire		68 / 70
Nivel presiune sonoră*1	U.I.*3	Răcire (P-Hi/Hi/Me/Lo)		44 / 34 / 30 / 27
		Încălzire (P-Hi/Hi/Me/Lo)		44 / 34 / 30 / 20
	U.E.	Răcire/Încălzire		53 / 54
Flux de aer	U.I.*3	Răcire (P-Hi/Hi/Me/Lo)	m ³ /min	26 / 17 / 14 / 11
		Încălzire (P-Hi/Hi/Me/Lo)		26 / 17 / 14 / 11
	U.E.	Răcire/Încălzire		100 / 100
Exterior dimensions	U.I.	HeightxWidthxDepth	mm	Unitate: 236 x 840 x 840 Panou: 35 x 950 x 950
	U.E.	U.I./U.E.		
Greutate netă				1,300 x 970 x 370 26(Unitate:21 Panou standard:5) / 97
Refrigerant Type GWP				R32/675
Ref.piping size	Lichid/Gaz		Ã,mm	9.52(3/8") / 15.88(5/8")
Lungime țeavă refrigerant (o direcție)			m	Max. 100
Diferență de nivel suportată		Unitate externă este mai sus/mai jos	m	Max.50 / Max.15
Interval de funcționare - temperatură exterioară		Răcire*2	°C	-15~50

Datorită politicii de continuă îmbunătățire a produselor, ne rezervăm dreptul de a modifica specificațiile tehnice fără nicio notificare prealabilă.



TEMPERATURE CONTROL FOR TODAY & TOMORROW



Încălzire	°C	-20~20	
Panou			White: T-PSA-5BW-E, T-PSAE-5BW-E / Black: T-PSA-5BB-E, T-PSAE-5BB-E
Filtru de aer, cantitate			Filtru lavabil din plastic x 1 (Lavabil)
Telecomandă (opțional)			Cu fir: RC-EX3A, RC-E5, RCH-E3 Wireless: RCN-T-5BW-E2, RCN-T-5BB-E2

Schema tehnica

Datorită politicii de continuă îmbunătățire a produselor, ne rezervăm dreptul de a modifica specificațiile tehnice fără nicio notificare prealabilă.



TEMPERATURE CONTROL FOR TODAY & TOMORROW



Models FDT40VH, 50VH, 60VH, 71VH

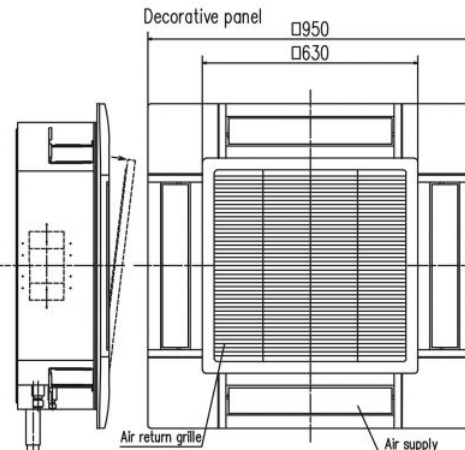
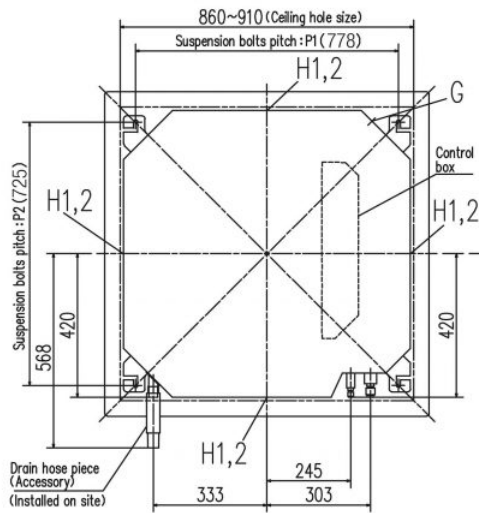

Symbol	Content		
	Model	40,50,60	71
A	Gas piping	φ12.7 (1/2") (Flare)	φ15.88 (5/8") (Flare)
B	Liquid piping	φ6.35 (1/4") (Flare)	φ9.52 (3/8") (Flare)
C	Drain piping	VP25 (O.D.32)	
D	Hole for wiring		
F	Suspension bolts	(M10 or M8)	
G	Outside air opening for ducting	(Knock out)	
H1	Air outlet opening for ducting	φ125 (Knock out)	
H2		φ200 (Knock out)	

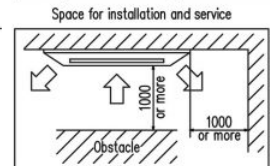

Make a space of 5000 or more between the units when installing more than one.

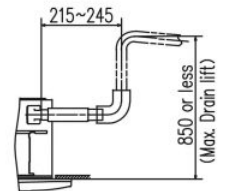
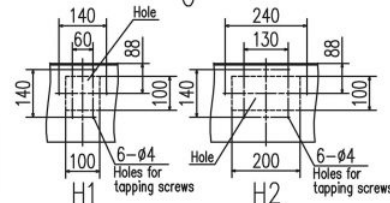
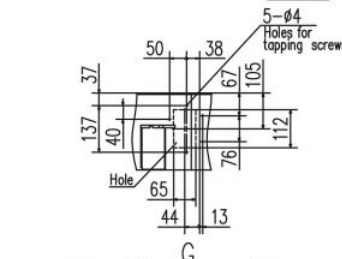
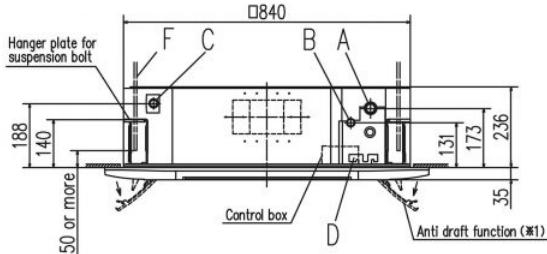

- Notes (1) The model name label is attached to the control box lid.
 (2) Suspension bolt pitch P1,P2 is adjustable by a pattern of the right table.
 (3) Section 1 (※1) is provided on the panel T-PSAE-5AW-E only.

Suspension bolt pitch range

Symbol	P1	P2
1	770	725~770
2	770~800	725

Datorită politicii de continuă îmbunătățire a produselor, ne rezervăm dreptul de a modifica specificațiile tehnice fără nicio notificare prealabilă.



TEMPERATURE CONTROL FOR TODAY & TOMORROW



FDC100VN-X-W, 125VN-X-W, 140VN-X-W, 100VS-X-W, 125VS-X-W, 140VS-X-W

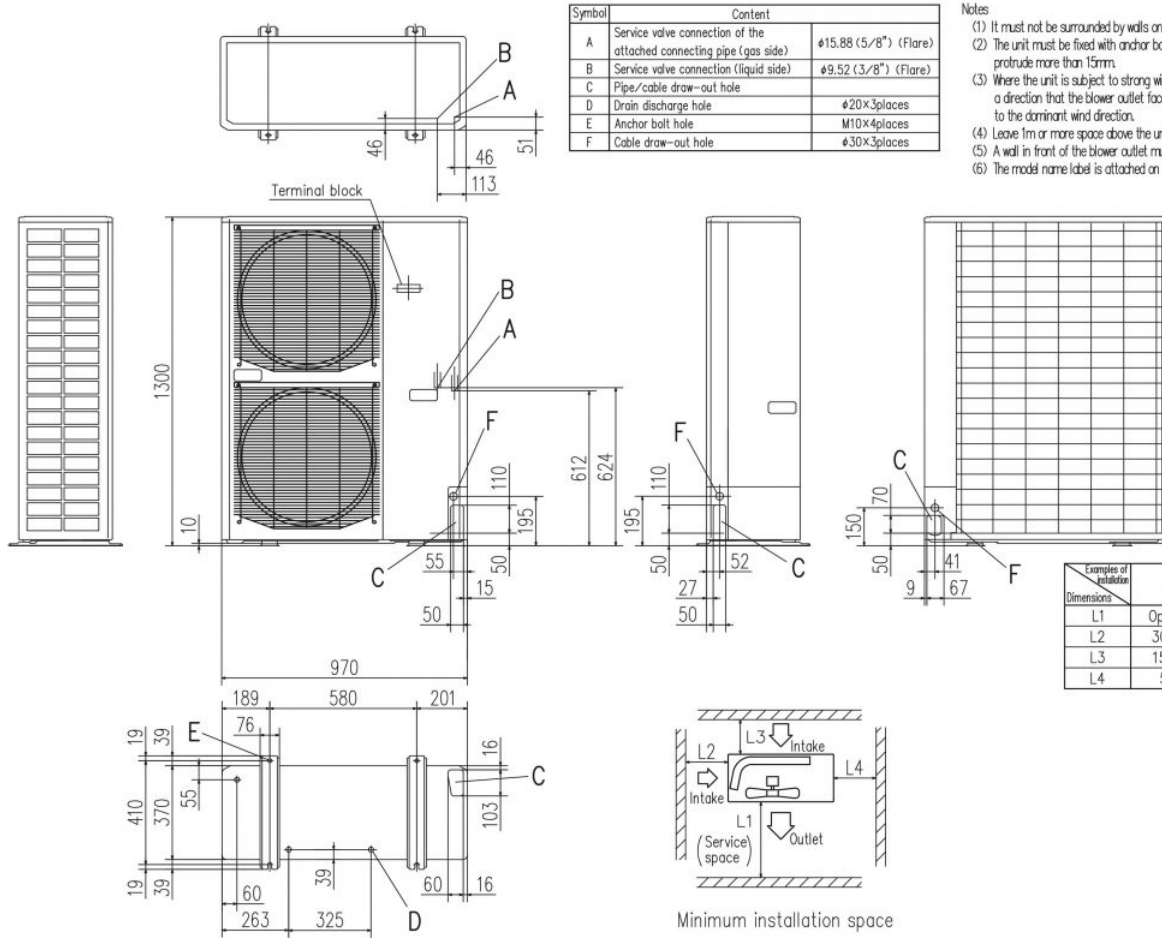

Symbol	Content	
A	Service valve connection of the attached connecting pipe (gas side)	φ15.88 (5/8") (Flare)
B	Service valve connection (liquid side)	φ9.52 (3/8") (Flare)
C	Pipe/cable draw-out hole	
D	Drain discharge hole	φ20×3places
E	Anchor bolt hole	M10×4places
F	Cable draw-out hole	φ30×3places

Notes

- (1) It must not be surrounded by walls on the four sides.
- (2) The unit must be fixed with anchor bolts. An anchor bolt must not protrude more than 15mm.
- (3) Where the unit is subject to strong winds, lay it in such a direction that the blower outlet faces perpendicularly to the dominant wind direction.
- (4) Leave 1m or more space above the unit.
- (5) A wall in front of the blower outlet must not exceed the units height.
- (6) The model name label is attached on the lower right corner of the front panel.

Example of installation Dimensions	I	II	III
L1	Open	Open	500
L2	300	5	Open
L3	150	300	150
L4	5	5	5

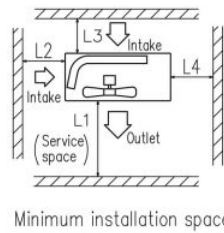

Datorită politicii de continuă îmbunătățire a produselor, ne rezervăm dreptul de a modifica specificațiile tehnice fără nicio notificare prealabilă.