



TEMPERATURE CONTROL
FOR **TODAY & TOMORROW**

MITSUBISHI
HEAVY INDUSTRIES

FDT125VSPVH

Capacitate nominala de racire: **12.5 KW**



Poze unitate interna si unitate externa



Specificatii

Unitate internă	FDT60VH x 2		
Unitate externă	FDC125VSX		
Sursă de alimentare	Trifazic 380-415V, 50Hz / 380V, 60Hz		
Capacitate nominală de răcire (Min-Max)	kW	12.5 (5.0 ~ 14.0)	
Capacitate nominală de încălzire (Min-Max)	kW	14.0 (4.0 ~ 18.0)	
Power Consumption	Răcire/Încălzire	kW	3.26 / 3.22
EER/COP	Răcire/Încălzire	kW	3.83 / 4.35



TEMPERATURE CONTROL FOR TODAY & TOMORROW



Curent de intrare			A	5
Max. current			A	15
Nivel putere sonoră*1	U.I.*3	Răcire/Încălzire	dB(A)	58 / 59
	U.E.	Răcire/Încălzire		70 / 70
Nivel presiune sonoră*1	U.I.*3	Răcire (P-Hi/Hi/Me/Lo)		44 / 34 / 30 / 27
		Încălzire (P-Hi/Hi/Me/Lo)		44 / 34 / 30 / 23
	U.E.	Răcire/Încălzire		48 / 50
Flux de aer	U.I.*3	Răcire (P-Hi/Hi/Me/Lo)	m ³ /min	26 / 17 / 14 / 11
		Încălzire (P-Hi/Hi/Me/Lo)		26 / 17 / 14 / 11
	U.E.	Răcire/Încălzire		100 / 100
Exterior dimensions	U.I.	HeightxWidthxDepth	mm	Unitate: 236 x 840 x 840 Panou: 35 x 950 x 950
	U.E.			
Greutate netă	U.E.	U.I./U.E.	mm kg	1,300 x 970 x 370 26(Unitate:21 Panou standard:5) / 105
Refrigerant Type GWP				R410A/2088
Ref.piping size	Lichid/Gaz		Ț, mm	9.52(3/8") / 15.88(5/8")
Lungime țeavă refrigerant (o direcție)			m	Max. 100
Diferență de nivel suportată	Unitate externă este mai sus/mai jos		m	Max.30 / Max.15
	Răcire*2		°C	-15~43
Interval de funcționare - temperatură exterioară				

Datorită politicii de continuă îmbunătățire a produselor, ne rezervăm dreptul de a modifica specificațiile tehnice fără nicio notificare prealabilă.



TEMPERATURE CONTROL FOR TODAY & TOMORROW



Încălzire	°C	-20~20	
Panou			White: T-PSA-5BW-E, T-PSAE-5BW-E / Black: T-PSA-5BB-E, T-PSAE-5BB-E
Filtru de aer, cantitate			Filtru lavabil din plastic x 1 (Lavabil)
Telecomandă (opțional)			Cu fir: RC-EX3A, RC-E5, RCH-E3 Wireless: RCN-T-5BW-E2, RCN-T-5BB-E2

Schema tehnica

Datorită politicii de continuă îmbunătățire a produselor, ne rezervăm dreptul de a modifica specificațiile tehnice fără nicio notificare prealabilă.



TEMPERATURE CONTROL FOR TODAY & TOMORROW



Models FDT40VH, 50VH, 60VH, 71VH

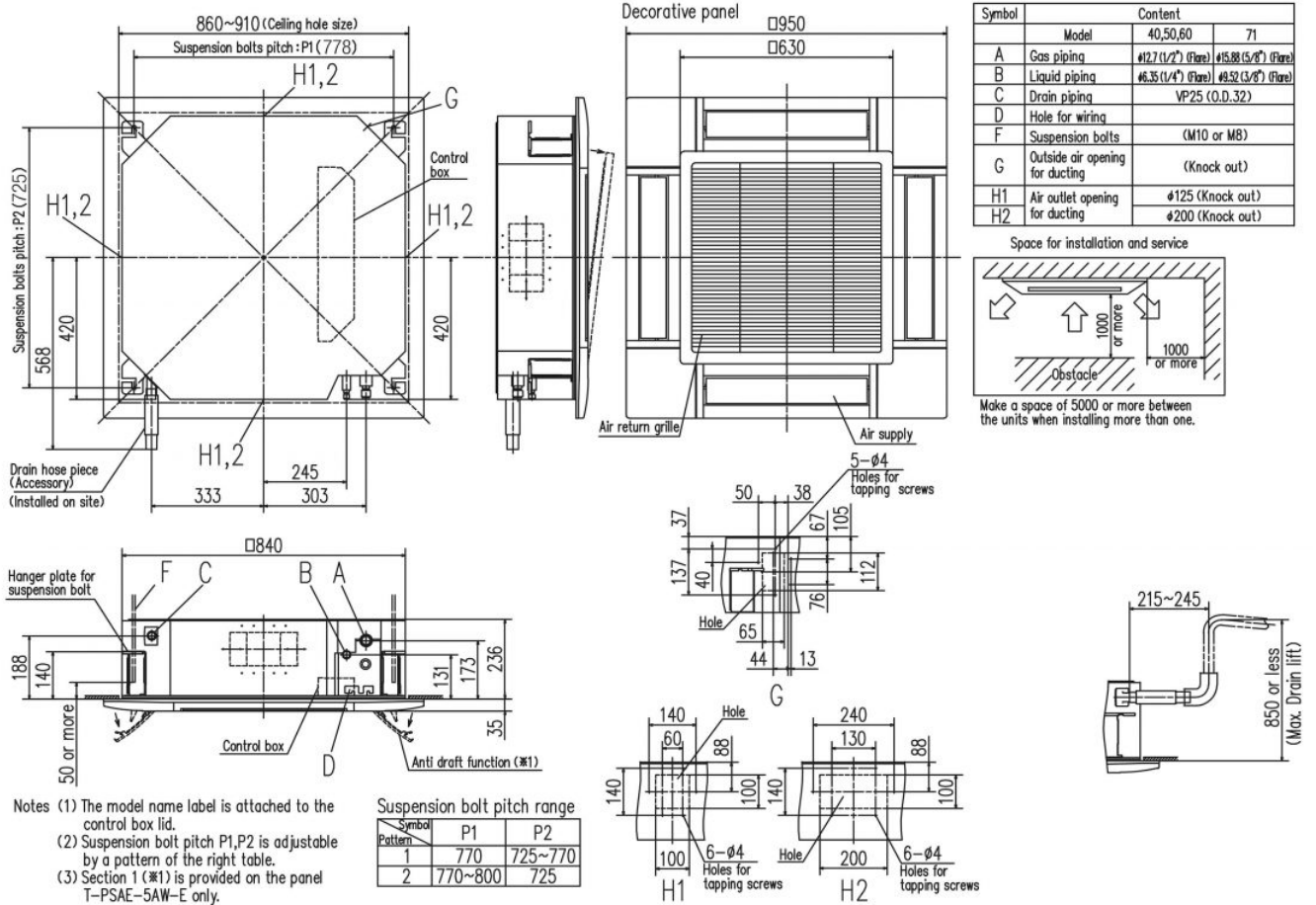

Datorită politicii de continuă îmbunătățire a produselor, ne rezervăm dreptul de a modifica specificațiile tehnice fără nicio notificare prealabilă.



TEMPERATURE CONTROL FOR TODAY & TOMORROW



FDC100VNX, 100VSX, 125VNX, 125VSX,
140VNX, 140VSX

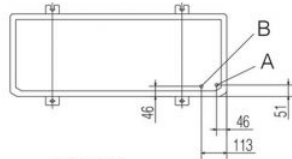

Symbol	Content
A	Service valve connection of the attached connecting pipe (gas side) $\phi 15.88$ (5/8") (Flare)
B	Service valve connection (liquid side) $\phi 9.52$ (3/8") (Flare)
C	Pipe / cable draw-out hole
D	Drain discharge hole $\phi 20 \times 3$ places
E	Anchor bolt hole M10 $\times 4$ places
F	Cable draw-out hole $\phi 30$ (front) $\phi 45$ (side) $\phi 50$ (back)

Notes

- (1) It must not be surrounded by walls on the four sides.
- (2) The unit must be fixed with anchor bolts. An anchor bolt must not protrude more than 15mm.
- (3) Where the unit is subject to strong winds, lay it in such a direction that the blower outlet faces perpendicularly to the dominant wind direction.
- (4) Leave 1m or more space above the unit.
- (5) A wall in front of the blower outlet must not exceed the unit's height.
- (6) The model name label is attached on the lower right corner of the front panel.
- (7) Connect the Service valve with local pipe by using the pipe of the attachment. (Gas side only)

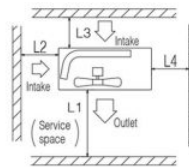
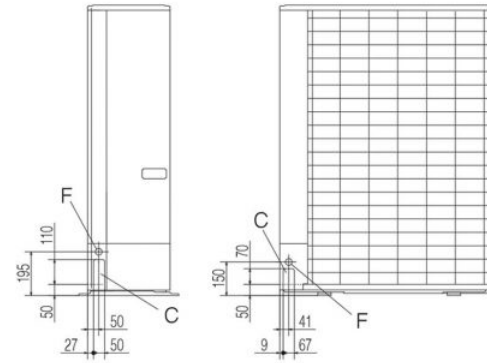
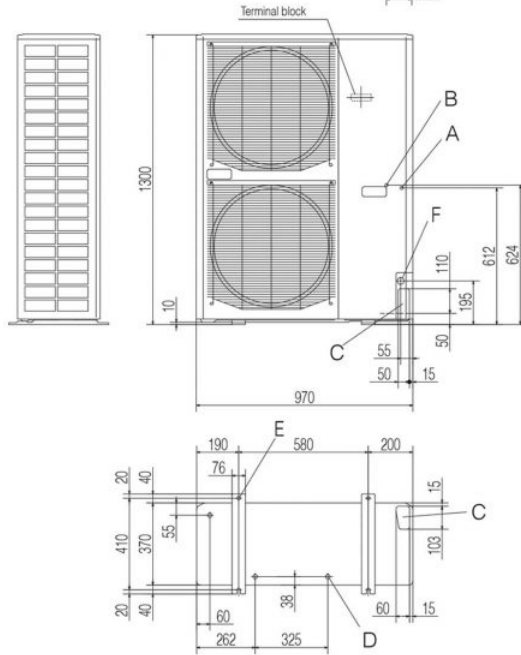

Minimum installation space

Examples of Dimensions	I	II	III
L1	Open	Open	500
L2	300	5	Open
L3	150	300	150
L4	5	5	5

Datorită politicii de continuă îmbunătățire a produselor, ne rezervăm dreptul de a modifica specificațiile tehnice fără nicio notificare prealabilă.