



TEMPERATURE CONTROL
FOR **TODAY & TOMORROW**

MITSUBISHI
HEAVY INDUSTRIES

FDT140VNAVH

Capacitate nominala de racire: **13.6 KW**



Poze unitate interna si unitate externa



Specificatii

Unitate internă		FDT140VH	
Unitate externă		FDC140VNA	
Sursă de alimentare		Monofazic 220-240V, 50Hz / 220V, 60Hz	
Capacitate nominală de răcire (Min~Max)		kW	13.6 (5.0 ~ 14.5)
Capacitate nominala de incalzire (Min~Max)		kW	15.5 (4.0 ~ 16.5)
Consumul de energie	Racire/Incalzire	kW	4.84 / 4.43
EER/COP	Racire/Incalzire		2.81 / 3.50



TEMPERATURE CONTROL FOR TODAY & TOMORROW



Curent de intrare		A	5
Amperaj maxim		A	24
Nivel putere sonoră*1	U.I.	Racire/Incalzire	dB(A) 63 / 64
	U.E.	Racire/Incalzire	73 / 73
Nivel presiune sonoră*1	U.I.	Racire (Hi/Me/Lo/Ulo)	48 / 42 / 39 / 32
		Incalzire (Hi/Me/Lo/Ulo)	48 / 41 / 38 / 31
	U.E.	Racire/Incalzire	57 / 59
Flux de aer	U.I.	Racire (Hi/Me/Lo/Ulo)	m ³ /min 38 / 29 / 26 / 19
		Incalzire (Hi/Me/Lo/Ulo)	38 / 29 / 26 / 19
	U.E.	Racire/Incalzire	75 / 73
Dimensiuni exterioare	U.I.	Inaltime x Latime x Adancime	mm Unitate: 298 x 840 x 840 Panou: 35 x 950 x 950
	U.E.		
Greutate netă	U.E.		845 x 970 x 370
	U.I. / U.E.		30 (Unitate:25 Panou standard:5) / 80
Refrigerant		Tip/GWP	R410A/2088
Dimensiuni țevă refrigerant		Lichid/Gaz	ø mm 9.52(3/8") / 15.88(5/8")
Lungime teava refrigerant (o directie)		m	Max.50
Diferenta de nivel suportata	Unitate externă este mai sus/mai jos		m Max.50 / Max.15
	Racire*2		°C -15~50
Interval de functionare - temperatura exterioara			

Datorită politicii de continuă îmbunătățire a produselor, ne rezervăm dreptul de a modifica specificațiile tehnice fără nicio notificare prealabilă.



TEMPERATURE CONTROL FOR TODAY & TOMORROW



Incalzire	-20~20	
Panou		T-PSA-5BW-E, T-PSAE-5BW-E (Alb) / T-PSA-5BB-E, T-PSAE-5BB-E (Negru)
Filtru de aer		Filtru lavabil x 1(Lavabil)
Telecomanda (opționalal)		Cu fir: RC-EX3A, RC-E5, RCH-E3 Fara fir: RCN-T-5BW-E2, RCN-T-5BB-E2
SEER		6.16
SCOP (Climat temperat)		4.28

Schema tehnica

Datorită politicii de continuă îmbunătățire a produselor, ne rezervăm dreptul de a modifica specificațiile tehnice fără nicio notificare prealabilă.



TEMPERATURE CONTROL FOR TODAY & TOMORROW



Models FDT100VH, 125VH, 140VH

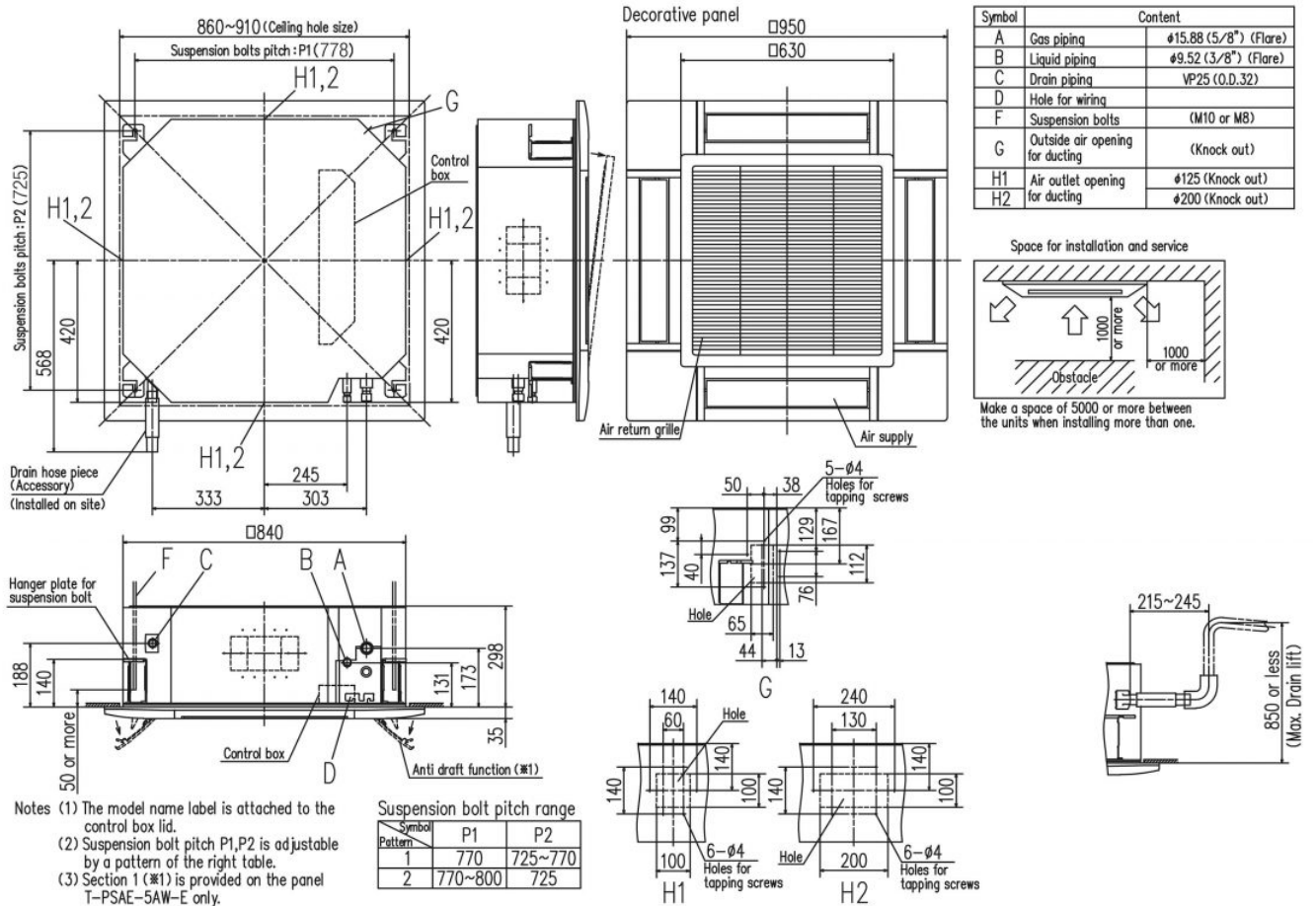

Datorită politicii de continuă îmbunătățire a produselor, ne rezervăm dreptul de a modifica specificațiile tehnice fără nicio notificare prealabilă.



TEMPERATURE CONTROL FOR TODAY & TOMORROW



FDC100VNA, 125VNA, 140VNA
100VSA, 125VSA, 140VSA

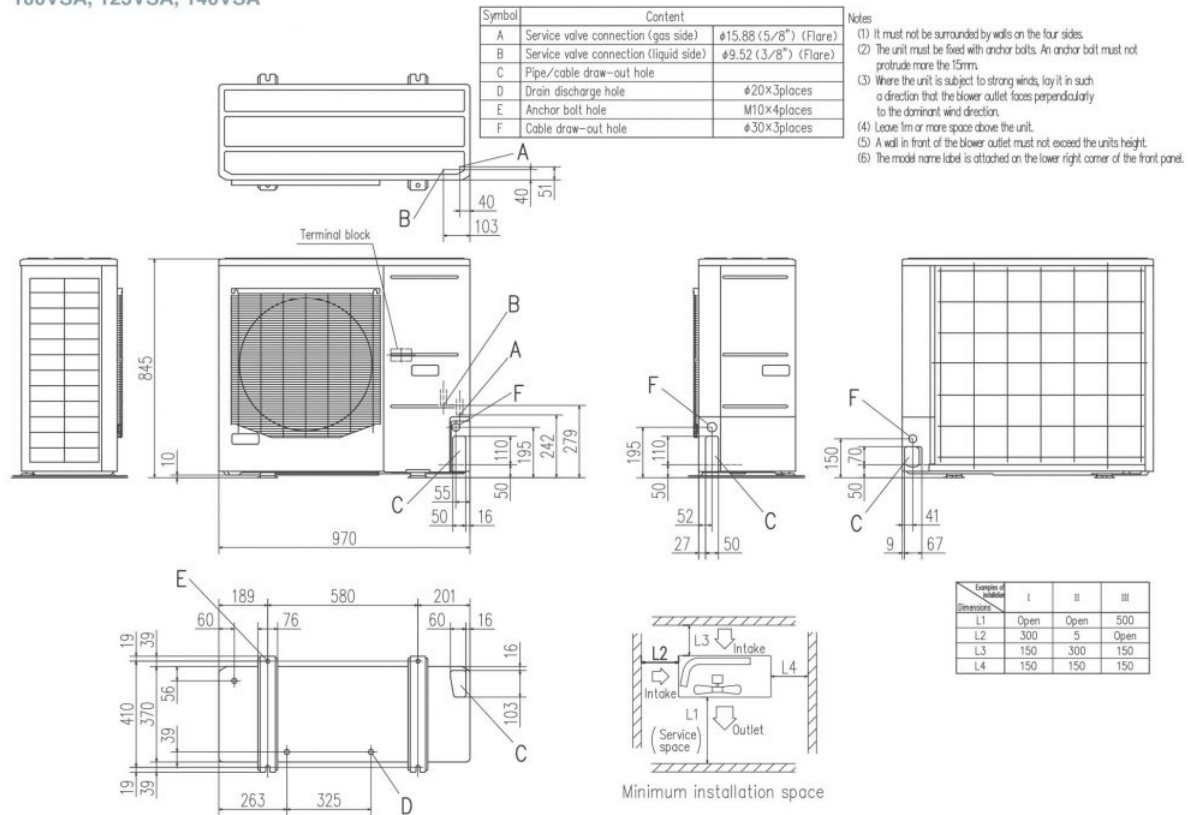

Datorită politicii de continuă îmbunătățire a produselor, ne rezervăm dreptul de a modifica specificațiile tehnice fără nicio notificare prealabilă.