



TEMPERATURE CONTROL
FOR TODAY & TOMORROW

MITSUBISHI
HEAVY INDUSTRIES

FDT200VSA WPVH

Capacitate nominala de racire: **20.0 KW**



Poze unitate interna si unitate externa



Specificatii

Unitate internă		FDT100VH x 2	
Unitate externă		FDC200VSA-W	
Sursă de alimentare		Trifazic 380-415V, 50Hz / 380V, 60Hz	
Capacitate nominală de răcire (Min-Max)		kW	20.0 (6.8 ~ 22.4)
Capacitate nominală de încălzire (Min-Max)		kW	22.4 (6.6 ~ 25.0)
Power Consumption	Răcire/Încălzire	kW	5.48 / 5.27
EER/COP	Răcire/Încălzire	kW	3.65 / 4.25



TEMPERATURE CONTROL FOR TODAY & TOMORROW



Curent de intrare			A	5
Max. current			A	19
Nivel putere sonoră*1	U.I.*3	Răcire/Încălzire	dB(A)	62 / 62
	U.E.	Răcire/Încălzire		72 / 74
Nivel presiune sonoră*1	U.I.*3	Răcire (P-Hi/Hi/Me/Lo)		47 / 39 / 36 / 30
		Încălzire (P-Hi/Hi/Me/Lo)		47 / 39 / 36 / 29
	U.E.	Răcire/Încălzire		58 / 59
Flux de aer	U.I.*3	Răcire (P-Hi/Hi/Me/Lo)	m ³ /min	37 / 26 / 23 / 17
		Încălzire (P-Hi/Hi/Me/Lo)		37 / 26 / 23 / 17
	U.E.	Răcire/Încălzire		148 / 134
Exterior dimensions	U.I.	HeightxWidthxDepth	mm	Unitate: 298 x 840 x 840 Panou: 35 x 950 x 950
	U.E.			
Greutate netă	U.E.	U.I./U.E.	mm kg	1,505 x 970 x 370 30(Unitate:25 Panou standard:5) / 144
Refrigerant Type GWP				R32/675
Ref.piping size	Lichid/Gaz		Ț, mm	9.52(3/8") / 22.22(7/8")
Lungime țeavă refrigerant (o direcție)			m	Max. 70
Diferență de nivel suportată	Unitate externă este mai sus/mai jos		m	Max.50 / Max.15
	Răcire*2		°C	-15~50
Interval de funcționare - temperatură exterioară				

Datorită politicii de continuă îmbunătățire a produselor, ne rezervăm dreptul de a modifica specificațiile tehnice fără nicio notificare prealabilă.



TEMPERATURE CONTROL FOR TODAY & TOMORROW



Încălzire	°C	-20~20	
Panou			T-PSA-5BW-E, T-PSAE-5BW-E(Alb) / T-PSA-5BB-E, T-PSAE-5BB-E(Negru)
Filtru de aer, cantitate			Filtru lavabil din plastic x 1 (Lavabil)
Telecomandă (opțional)			Cu fir: RC-EX3A, RC-E5, RCH-E3 Wireless: RCN-T-5BW-E2, RCN-T-5BB-E2

Schema tehnica

Datorită politicii de continuă îmbunătățire a produselor, ne rezervăm dreptul de a modifica specificațiile tehnice fără nicio notificare prealabilă.



TEMPERATURE CONTROL FOR TODAY & TOMORROW



Models FDT100VH, 125VH, 140VH

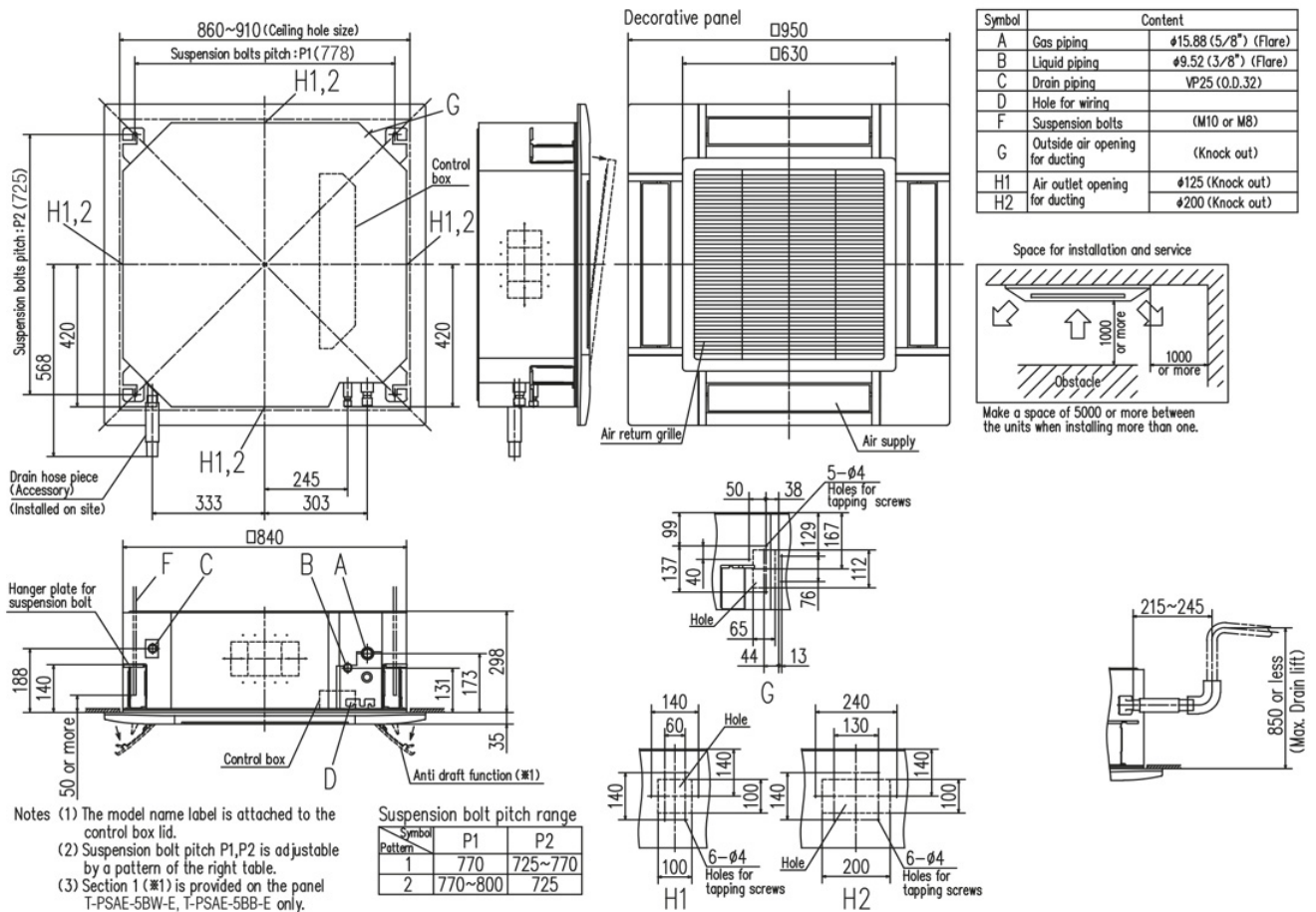

Datorită politicii de continuă îmbunătățire a produselor, ne rezervăm dreptul de a modifica specificațiile tehnice fără nicio notificare prealabilă.



TEMPERATURE CONTROL FOR TODAY & TOMORROW



FDC200VSA-W, 250VSA-W, FDC280VSA-W
FDC250VSA

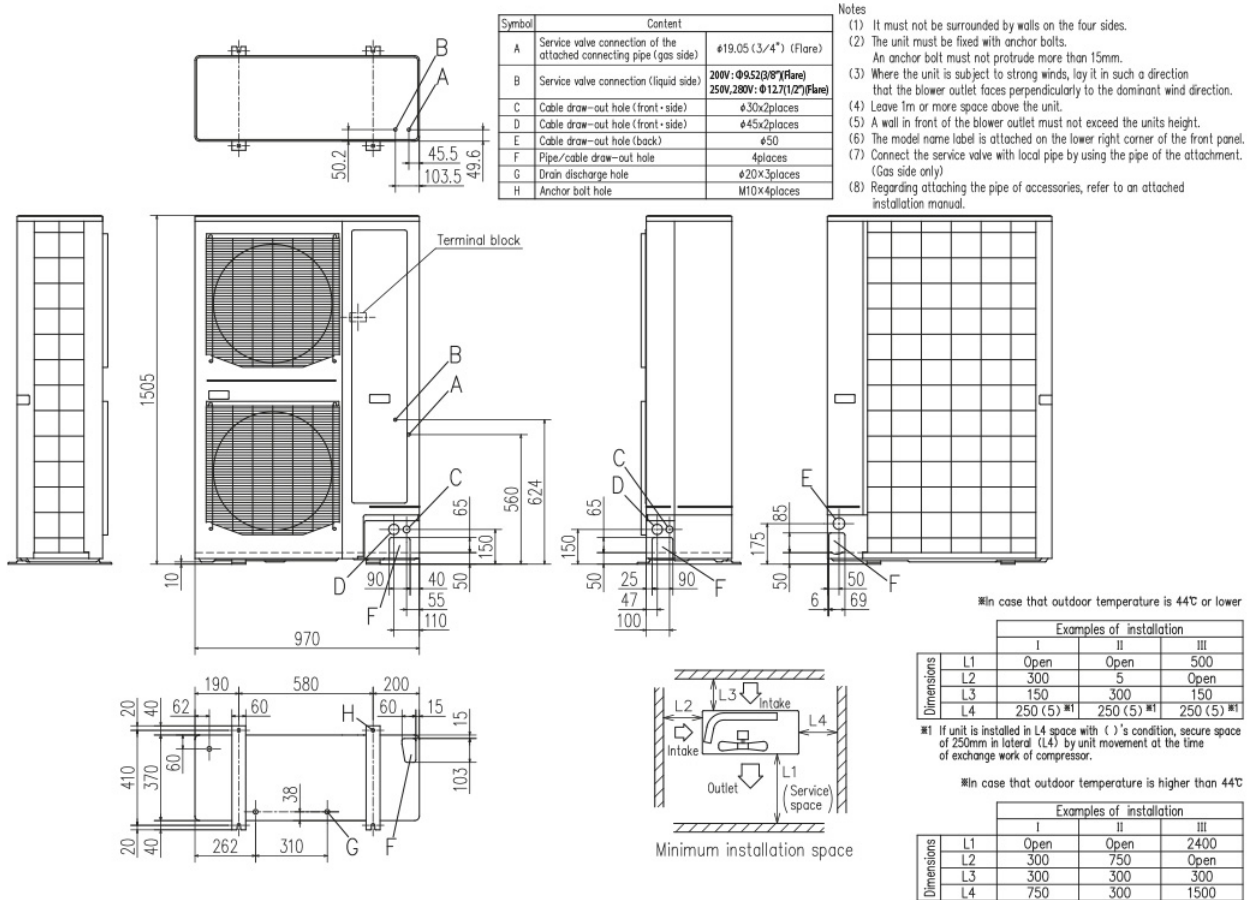

Datorită politicii de continuă îmbunătățire a produselor, ne rezervăm dreptul de a modifica specificațiile tehnice fără nicio notificare prealabilă.