



TEMPERATURE CONTROL  
FOR TODAY & TOMORROW

  
**MITSUBISHI**  
**HEAVY INDUSTRIES**

## FDT40ZSXVH

Capacitate nominala de racire: **4.0 KW**



## Poze unitate interna si unitate externa



## Specificatii

Unitate internă		FDT40VH	
Unitate externă		SRC40ZSX-S	
Sursă de alimentare		Monofazic 220-240V, 50Hz / 220V, 60Hz	
Capacitate nominală de răcire (Min~Max)		kW	4.0 ( 1.1 ~ 4.7 )
Capacitate nominala de incalzire (Min~Max)		kW	4.5 ( 0.6 ~ 5.4 )
Consumul de energie	Racire/Incalzire	kW	0.93 / 1.03
EER/COP	Racire/Incalzire		4.30 / 4.37



## TEMPERATURE CONTROL FOR TODAY & TOMORROW



Curent de intrare		A	5	
Amperaj maxim		A	12	
Nivel putere sonoră*1	U.I.	Racire/Incalzire	dB(A)	50 / 50
	U.E.	Racire/Incalzire		63 / 63
Nivel presiune sonoră*1	U.I.	Racire (Hi/Me/Lo/Ulo)		36 / 33 / 30 / 26
		Incalzire (Hi/Me/Lo/Ulo)		36 / 33 / 28 / 20
	U.E.	Racire/Incalzire		50 / 49
Flux de aer	U.I.	Racire (Hi/Me/Lo/Ulo)	m <sup>3</sup> /min	19 / 16 / 13 / 10
		Incalzire (Hi/Me/Lo/Ulo)		19 / 16 / 13 / 10
	U.E.	Racire/Incalzire		36 / 33
Dimensiuni exterioare	U.I.	Inaltime x Latime x Adancime	mm	Unitate: 236 x 840 x 840 Panou: 35 x 950 x 950
	U.E.			
Greutate netă	U.I. / U.E.		kg	640 x 800(+71) x 290 24(Unitate:19 Panou standard:5) / 45
Refrigerant		Tip/GWP		R410A/2088
Refrigerant		Incarcare	kg/TCO <sub>2</sub> Eq	1.5/3.132
Dimensiuni țeavă refrigerant		Lichid/Gaz	ø mm	6.35(1/4") / 12.7(1/2")
Lungime teava refrigerant (o directie)			m	Max.30
Diferenta de nivel suportata		Unitate externă este mai sus/mai jos	m	Max.20 / Max.20

**Datorită politicii de continuă îmbunătățire a produselor, ne rezervăm dreptul de a modifica specificațiile tehnice fără nicio notificare prealabilă.**



## TEMPERATURE CONTROL FOR TODAY & TOMORROW



Interval de functionare - temperatura exterioara	Racire*2	°C	-15~46
	Incalzire		-20~24
Panou			T-PSA-5BW-E, T-PSAE-5BW-E(Alb) / T-PSA-5BB-E, T-PSAE-5BB-E(Negru)
Filtru de aer			Filtru lavabil x 1(Lavabil)
Telecomanda (opționalal)			Cu fir: RC-EX3A, RC-E5, RCH-E3 Fara fir: RCN-T-5BW-E2, RCN-T-5BB-E2
Clasa energetica (Racire/Incalzire)			A+++ / A+
SEER			8.51
SCOP (Climat temperat)			4.47
Pdesign (racire/incalzire(@-10°C))		kW	4.0/3.8
Consumul anual de electricitate (racire/incalzire)		kWh/a	165/1192
Performanta in modul Incalzire			Medie

## Schema tehnica

---

**Datorită politicii de continuă îmbunătățire a produselor, ne rezervăm dreptul de a modifica specificațiile tehnice fără nicio notificare prealabilă.**



# TEMPERATURE CONTROL FOR TODAY & TOMORROW



Indoor units: FDT40VH, 50VH, 60VH, 71VH

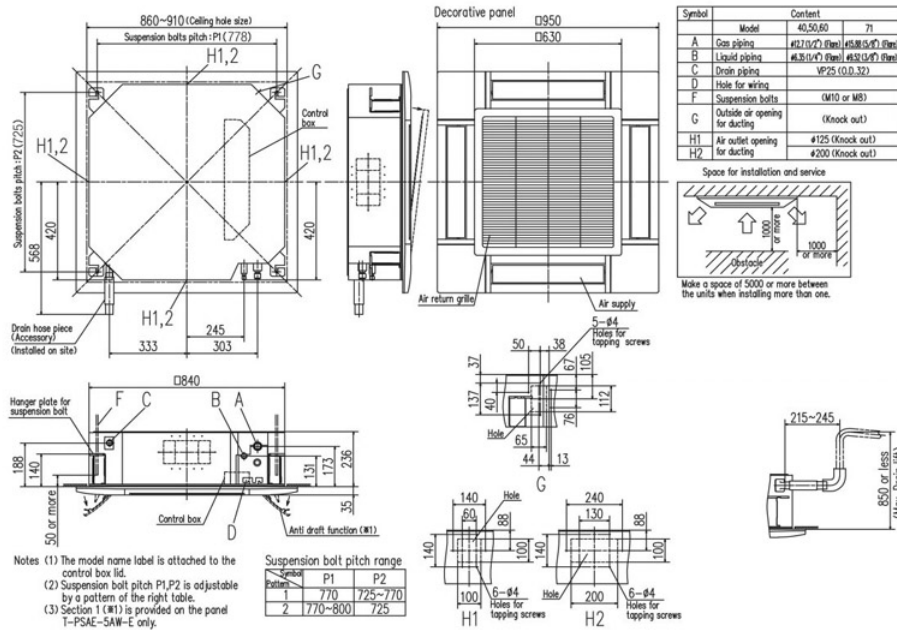

Unit: mm

Models SRC40ZSX-W1, 50ZSX-W1, 60ZSX-W1

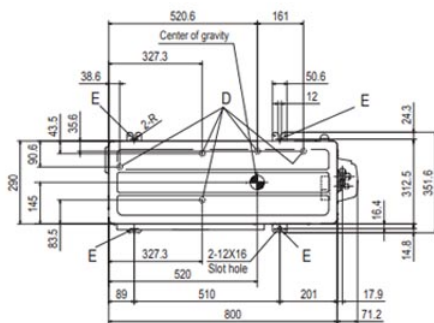

Notes

- The unit must not be surrounded by walls on the four sides.
- The unit must be fixed with anchor bolts. An anchor bolt must not protrude more than 15mm.
- If the unit is installed in the location where there is a possibility of strong winds, place the unit such that the direction of air from the outlet gets perpendicular to the wind direction.
- Leave 200mm or more space above the unit.
- The wall height on the outlet side should be 1200mm or less.
- The model name label is attached on the front side of the unit.

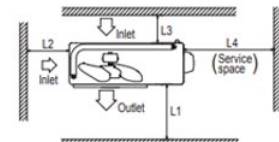

Minimum installation space

Examples installation	I	II	III	IV
L1	Open	280	280	180
L2	100	75	Open	Open
L3	100	80	80	80
L4	250	Open	250	Open

Symbol	Content
A	Service valve connection (Gas side) $\phi 12.7(1/2)$ (Flare)
B	Service valve connection (Liquid side) $\phi 6.35(1/4)$ (Flare)
C	Pipe / cable draw-out hole
D	Drain discharge hole $\phi 20 \times 5$ places
E	Anchor bolt hole M10-12 $\times$ 4 places

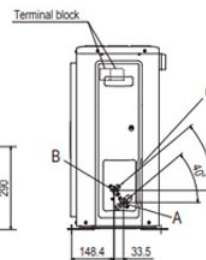
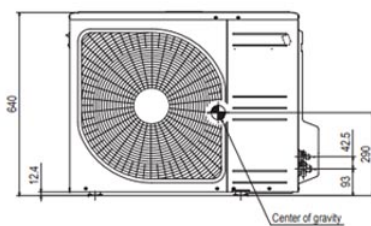

**Datorită politicii de continuă îmbunătățire a produselor, ne rezervăm dreptul de a modifica specificațiile tehnice fără nicio notificare prealabilă.**