



TEMPERATURE CONTROL
FOR TODAY & TOMORROW

MITSUBISHI
HEAVY INDUSTRIES

FDT60ZSXVH

Capacitate nominala de racire: **5.6 KW**



Poze unitate interna si unitate externa



Specificatii

Unitate internă		FDT60VH	
Unitate externă		SRC60ZSX-S	
Sursă de alimentare		Monofazic 220-240V, 50Hz / 220V, 60Hz	
Capacitate nominală de răcire (Min~Max)		kW	5.6 (1.1 ~ 6.3)
Capacitate nominala de incalzire (Min~Max)		kW	6.7 (0.6 ~ 7.1)
Consumul de energie	Racire/Incalzire	kW	1.52 / 1.56
EER/COP	Racire/Incalzire		3.68 / 4.29



TEMPERATURE CONTROL FOR TODAY & TOMORROW



Curent de intrare		A	5	
Amperaj maxim		A	15	
Nivel putere sonoră*1	U.I.	Racire/Incalzire	dB(A)	58 / 59
	U.E.	Racire/Incalzire		65 / 64
Nivel presiune sonoră*1	U.I.	Racire (Hi/Me/Lo/Ulo)		44 / 34 / 30 / 27
		Incalzire (Hi/Me/Lo/Ulo)		44 / 34 / 30 / 23
	U.E.	Racire/Incalzire		52 / 52
Flux de aer	U.I.	Racire (Hi/Me/Lo/Ulo)	m ³ /min	26 / 17 / 14 / 11
		Incalzire (Hi/Me/Lo/Ulo)		26 / 17 / 14 / 11
	U.E.	Racire/Incalzire		41.5 / 39
Dimensiuni exterioare	U.I.	Inaltime x Latime x Adancime	mm	Unitate: 236 x 840 x 840 Panou: 35 x 950 x 950
	U.E.			
Greutate netă	U.I. / U.E.		kg	640 x 800(+71) x 290 26(Unitate:21 Panou standard:5) / 60
Refrigerant		Tip/GWP		R410A/2088
Refrigerant		Incarcare	kg/TCO ₂ Eq	1.5/3.132
Dimensiuni țevă refrigerant		Lichid/Gaz	ø mm	6.35(1/4") / 12.7(1/2")
Lungime teava refrigerant (o directie)			m	Max.30
Diferenta de nivel suportata		Unitate externă este mai sus/mai jos	m	Max.20 / Max.20

Datorită politicii de continuă îmbunătățire a produselor, ne rezervăm dreptul de a modifica specificațiile tehnice fără nicio notificare prealabilă.



TEMPERATURE CONTROL FOR TODAY & TOMORROW



Interval de functionare - temperatura exterioara	Racire*2	°C	-15~46
	Incalzire		-20~24
Panou			T-PSA-5BW-E, T-PSAE-5BW-E (Alb) / T-PSA-5BB-E, T-PSAE- 5BB-E (Negru)
Filtru de aer			Filtru lavabil x 1(Lavabil)
Telecomanda (opționalal)			Cu fir: RC-EX3A, RC-E5, RCH- E3 Fara fir: RCN-T-5BW-E2, RCN-T-5BB-E2
Clasa energetica (Racire/Incalzire)			A++/A++
SEER			8.26
SCOP (Climat temperat)			5.00
Pdesign (racire/incalzire(@-10°C))		kW	5.6/4.7
Consumul anual de electricitate (racire/incalzire)		kWh/a	238/1316
Performanta in modul Incalzire			Medie

Schema tehnica

Datorită politicii de continuă îmbunătățire a produselor, ne rezervăm dreptul de a modifica specificațiile tehnice fără nicio notificare prealabilă.



TEMPERATURE CONTROL FOR TODAY & TOMORROW



SRC40ZSX-W1, 50ZSX-W1, 60ZSX-W1 SRC40ZSX-S, 50ZSX-S, 60ZSX-S

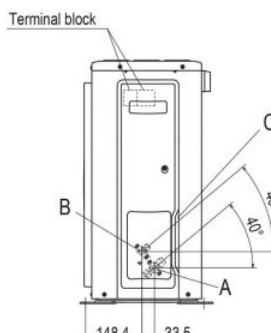
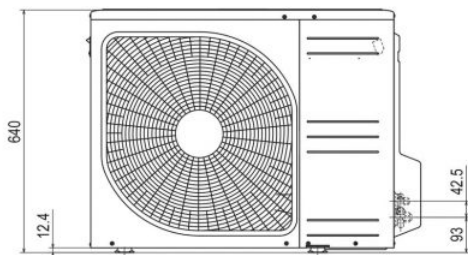
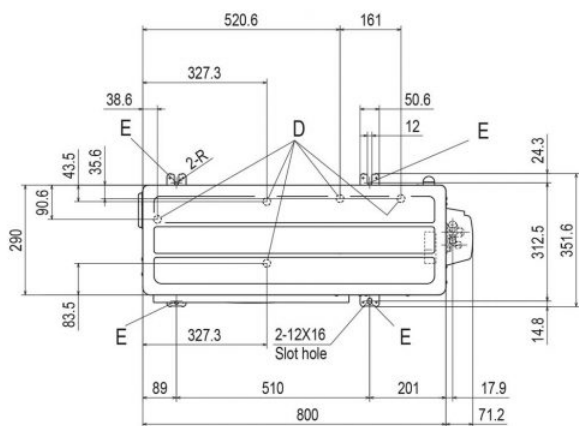

Symbol	Content	
A	Service valve connection (Gas side)	φ 12.7(1/2")(Flare)
B	Service valve connection (Liquid side)	φ 6.35(1/4")(Flare)
C	Pipe/cable draw-out hole	
D	Drain discharge hole	φ 20×5 places
E	Anchor bolt hole	M10-12×4 places

Notes

- (1) The unit must not be surrounded by walls on the four sides.
- (2) The unit must be fixed with anchor bolts. An anchor bolt must not protrude more than 15mm.
- (3) If the unit is installed in the location where there is a possibility of strong winds, place the unit such that the direction of air from the outlet gets perpendicular to the wind direction.
- (4) Leave 200mm or more space above the unit.
- (5) The wall height on the outlet side should be 1200mm or less.
- (6) The model name label is attached on the front side of the unit.

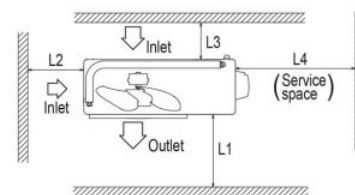

Minimum installation space

Examples installation	I	II	III	IV
Size				
L1	Open	280	280	180
L2	100	75	Open	Open
L3	100	80	80	80
L4	250	Open	250	Open

Datorită politicii de continuă îmbunătățire a produselor, ne rezervăm dreptul de a modifica specificațiile tehnice fără nicio notificare prealabilă.