



TEMPERATURE CONTROL
FOR TODAY & TOMORROW

MITSUBISHI
HEAVY INDUSTRIES

FDTC140VSATVH

Capacitate nominala de racire: **13.6 KW**



Poze unitate interna si unitate externa



Specificatii

Unitate internă		FDTC50VH x 3	
Unitate externă		FDC140VSA	
Sursă de alimentare		Trifazic 380-415V, 50Hz / 380V, 60Hz	
Capacitate nominală de răcire (Min-Max)		kW	13.6 (5.0 ~ 14.5)
Capacitate nominală de încălzire (Min-Max)		kW	15.5 (4.0 ~ 16.5)
Power Consumption	Răcire/Încălzire	kW	4.75 / 4.60
EER/COP	Răcire/Încălzire	kW	2.86 / 3.37



TEMPERATURE CONTROL FOR TODAY & TOMORROW



Curent de intrare			A	5
Max. current			A	15
Nivel putere sonoră*1	U.I.*3	Răcire/Încălzire	dB(A)	59 / 59
	U.E.	Răcire/Încălzire		73 / 73
Nivel presiune sonoră*1	U.I.*3	Răcire (P-Hi/Hi/Me/Lo)		44 / 40 / 35 / 27
		Încălzire (P-Hi/Hi/Me/Lo)		44 / 40 / 35 / 27
	U.E.	Răcire/Încălzire		57 / 59
Flux de aer	U.I.*3	Răcire (P-Hi/Hi/Me/Lo)	m ³ /min	13 / 11 / 9 / 7
		Încălzire (P-Hi/Hi/Me/Lo)		13 / 11 / 9 / 7
	U.E.	Răcire/Încălzire		75 / 73
Exterior dimensions	U.I.	HeightxWidthxDepth	mm	Unitate: 248 x 570 x 570 Panou: 10 x 620 x 620
	U.E.	U.I./U.E.		mm kg
Refrigerant Type GWP				R410A/2088
Ref.piping size	Lichid/Gaz		Ț, mm	9.52(3/8") / 15.88(5/8")
Lungime țeavă refrigerant (o direcție)			m	Max.50
Diferență de nivel suportată	Unitate externă este mai sus/mai jos		m	Max.50 / Max.15
Interval de funcționare - temperatură exterioară	Răcire*2		°C	-15~50

Datorită politicii de continuă îmbunătățire a produselor, ne rezervăm dreptul de a modifica specificațiile tehnice fără nicio notificare prealabilă.



TEMPERATURE CONTROL FOR TODAY & TOMORROW



Încălzire	°C	-20~20	
Panou			TC-PSA-5AW-E, TC-PSAE-5AW-E, ETC-PSA-5AW-E, TC-PSAE-5AW-E(Fagure) / TC-PSAG-5AW-E, TC-PSAGE-5AW-E(Grid)
Filtru de aer, cantitate			Filtru lavabil din plastic x 1 (Lavabil)
Telecomandă (opțional)			Cu fir:RC-EX3A, RC-E5, RCH-E3, Wireless:RCN-TC-5AW-E2, -E3

Schema tehnica

FDTC25VH1 FDTC35VH1 FDTC40VH FDTC50VH FDTC60VH

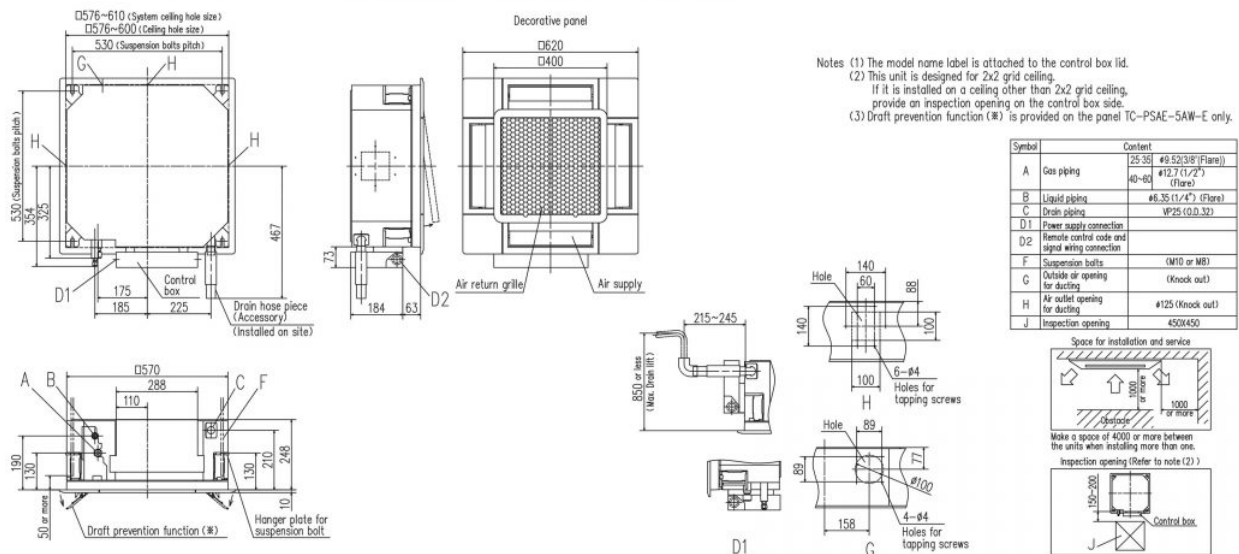

Datorită politicii de continuă îmbunătățire a produselor, ne rezervăm dreptul de a modifica specificațiile tehnice fără nicio notificare prealabilă.



TEMPERATURE CONTROL FOR TODAY & TOMORROW



FDC100VNA, 125VNA, 140VNA
100VSA, 125VSA, 140VSA

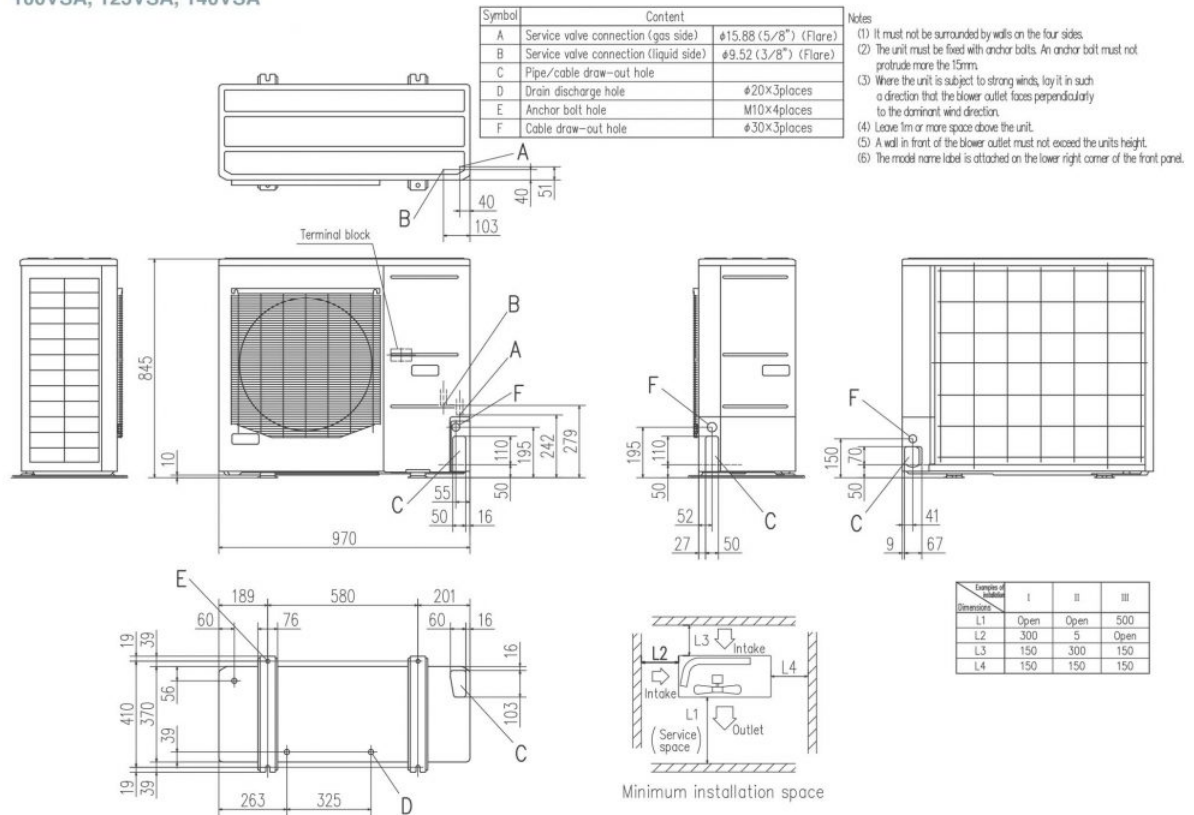

Datorită politicii de continuă îmbunătățire a produselor, ne rezervăm dreptul de a modifica specificațiile tehnice fără nicio notificare prealabilă.