



TEMPERATURE CONTROL
FOR TODAY & TOMORROW

MITSUBISHI
HEAVY INDUSTRIES

FDTC200VSADVH

Capacitate nominala de racire: **19.0 KW**



Poze unitate interna si unitate externa



Specificatii

Unitate internă		FDTC50VH x 4	
Unitate externă		FDC200VSA	
Sursă de alimentare		Trifazic 380-415V, 50Hz / 380V, 60Hz	
Capacitate nominală de răcire (Min-Max)		kW	19.0 (5.2 ~ 22.4)
Capacitate nominală de încălzire (Min-Max)		kW	22.4 (3.3 ~ 25.0)
Power Consumption	Răcire/Încălzire	kW	6.95 / 10.7
EER/COP	Răcire/Încălzire	kW	2.73 / 2.10



TEMPERATURE CONTROL FOR TODAY & TOMORROW



Curent de intrare			A	5
Max. current			A	20
Nivel putere sonoră*1	U.I.*3	Răcire/Încălzire	dB(A)	59 / 59
	U.E.	Răcire/Încălzire		72 / 74
Nivel presiune sonoră*1	U.I.*3	Răcire (P-Hi/Hi/Me/Lo)		44 / 40 / 35 / 27
		Încălzire (P-Hi/Hi/Me/Lo)		44 / 40 / 35 / 27
	U.E.	Răcire/Încălzire		58 / 59
Flux de aer	U.I.*3	Răcire (P-Hi/Hi/Me/Lo)	m ³ /min	13 / 11 / 9 / 7
		Încălzire (P-Hi/Hi/Me/Lo)		13 / 11 / 9 / 7
	U.E.	Răcire/Încălzire		135 / 135
Exterior dimensions	U.I.	HeightxWidthxDepth	mm	Unitate: 248 x 570 x 570 Panou: 10 x 620 x 620
Greutate netă	U.E.	U.I./U.E.	mm kg	1,300 x 970 x 370 16.5(Unitate:14 Panou standard:2.5) / 115
Refrigerant Type GWP				R410A/2088
Ref.piping size	Lichid/Gaz		Ț, mm	9.52(3/8") / 22.22(7/8")
Lungime țeavă refrigerant (o direcție)			m	Max.70
Diferență de nivel suportată		Unitate externă este mai sus/mai jos	m	Max.30 / Max.15
Interval de funcționare - temperatură exterioară		Răcire*2	°C	-15~50

Datorită politicii de continuă îmbunătățire a produselor, ne rezervăm dreptul de a modifica specificațiile tehnice fără nicio notificare prealabilă.



TEMPERATURE CONTROL FOR TODAY & TOMORROW



Încălzire	°C	-15~20	
Panou			TC-PSA-5AW-E, TC-PSAE-5AW-E(Fagure) / TC-PSAG-5AW-E, TC-PSAGE-5AW-E(Grid)
Filtru de aer, cantitate			Filtru lavabil din plastic x 1 (Lavabil)
Telecomandă (opțional)			Cu fir:RC-EX3A, RC-E5, RCH-E3, Wireless:RCN-TC-5AW-E2, -E3

Schema tehnica

FDTC25VH1 FDTC35VH1 FDTC40VH FDTC50VH FDTC60VH

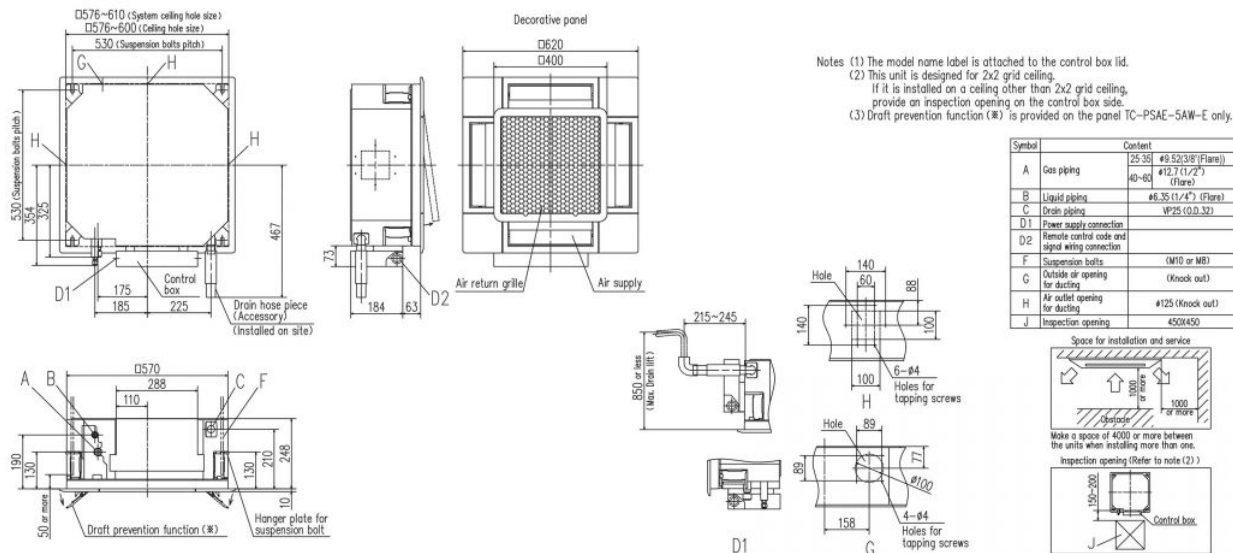

Datorită politicii de continuă îmbunătățire a produselor, ne rezervăm dreptul de a modifica specificațiile tehnice fără nicio notificare prealabilă.



TEMPERATURE CONTROL FOR TODAY & TOMORROW



FDC200VSA

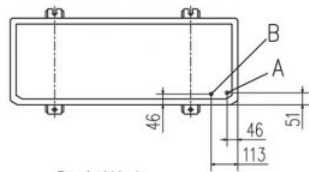

Symbol	Content	
A	Service valve connection of the attached connecting pipe (gas side)	φ19.05 (3/4") (Flare)
B	Service valve connection (liquid side)	φ9.52 (3/8") (Flare)
C	Pipe/cable draw-out hole	
D	Drain discharge hole	φ20×3places
E	Anchor bolt hole	M10×4places
F	Cable draw-out hole	φ30 (front) φ30 (side) φ30 (back)

Notes

- (1) It must not be surrounded by walls on the four sides.
- (2) The unit must be fixed with anchor bolts. An anchor bolt must not protrude more than 15mm.
- (3) Where the unit is subject to strong winds, lay it in such a direction that the blower outlet faces perpendicularly to the dominant wind direction.
- (4) Leave 1m or more space above the unit.
- (5) A wall in front of the blower outlet must not exceed the units height.
- (6) The model name label is attached on the lower right corner of the front panel.
- (7) Connect the Service valve with local pipe by using the pipe of the attachment. (Gas side only)
- (8) Regarding attaching the pipe of accessories, refer to an attached installation manual.

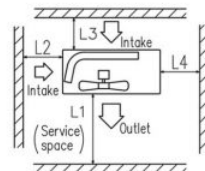
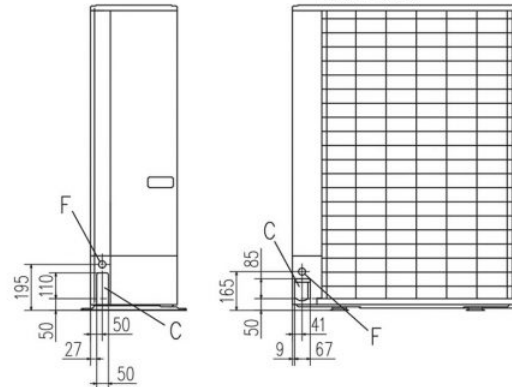
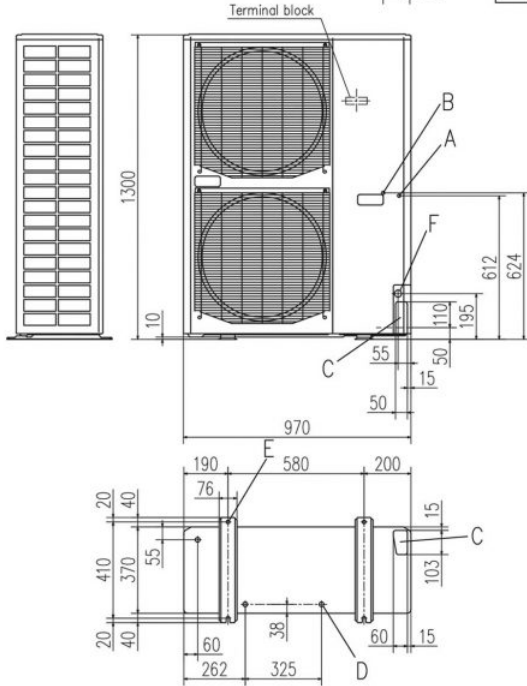

Minimum installation space

Dimensions	Examples of installation		
	I	II	III
L1	Open	Open	500
L2	300	5	Open
L3	150	300	150
L4	5	5	5

Datorită politicii de continuă îmbunătățire a produselor, ne rezervăm dreptul de a modifica specificațiile tehnice fără nicio notificare prealabilă.