



TEMPERATURE CONTROL
FOR **TODAY & TOMORROW**

MITSUBISHI
HEAVY INDUSTRIES

FDTC50ZSXVH

Capacitate nominala de racire: **5.0 KW**



Poze unitate interna si unitate externa



Specificatii

Unitate internă		FDTC50VH	
Unitate externă		SRC50ZSX-S	
Sursă de alimentare		Monofazic 220-240V, 50Hz / 220V, 60Hz	
Capacitate nominală de răcire (Min~Max)		kW	5.0 (1.1 ~ 5.6)
Capacitate nominală de încălzire (Min~Max)		kW	5.4 (0.6 ~ 6.3)
Consum de energie	Răcire/Încălzire	kW	1.43 / 1.53
EER/COP	Răcire/Încălzire		3.50 / 3.53



TEMPERATURE CONTROL FOR TODAY & TOMORROW



Curent de intrare			A	5
Amperaj maxim			A	15
Nivel putere sonoră*1	U.I.	Răcire/Încălzire	dB(A)	59 / 59
	U.E.	Răcire/Încălzire		63 / 63
Nivel presiune sonoră*1	U.I.	Răcire (Hi/Me/Lo/Ulo)		44 / 40 / 35 / 27
		Încălzire (Hi/Me/Lo/Ulo)	44 / 40 / 35 / 27	
	U.E.	Răcire/Încălzire	50 / 49	
Flux de aer	U.I.	Răcire (Hi/Me/Lo/Ulo)	m ³ /min	13 / 11 / 9 / 7
		Încălzire (Hi/Me/Lo/Ulo)		13 / 11 / 9 / 7
	U.E.	Răcire/Încălzire		40 / 33
Dimensiuni exterioare	U.I.	Înălțime / Lățime / Adâncime	mm	Unitate: 248 x 570 x 570 Panou: 10 x 620 x 620
	U.E.			640 x 800(+71) x 290
Greutate netă	U.I. / U.E.		kg	16.5(Unitate:14 Panou standard:2.5) / 45
Refrigerant		Tip/GWP		R410A/2088
Refrigerant		Încărcare	kg/TCO ₂ Eq	1.5/3.132
Dimensiuni țevă refrigerant		Lichid/Gaz	mm/ø	6.35(1/4") / 12.7(1/2")
Lungime țevă refrigerant (o direcție)			m	Max.30

Datorită politicii de continuă îmbunătățire a produselor, ne rezervăm dreptul de a modifica specificațiile tehnice fără nicio notificare prealabilă.



TEMPERATURE CONTROL FOR TODAY & TOMORROW



Diferență de nivel suportată	Unitate externă este mai sus/mai jos	m	Max.20 / Max.20
Interval de funcționare - temperatură exterioară	Răcire*2	°C	-15~46
	Încălzire		-20~24
Panou			TC-PSA-5AW-E, TC-PSAE-5AW-E(Fagure) / TC-PSAG-5AW-E, TC-PSAGE-5AW-E(Grid)
Filtru de aer (cantitate)			Filtru lavabil din plastic x 1 (Lavabil)
Telecomandă (opțional)			Cu fir:RC-EX3A, RC-E5, RCH-E3 Wireless:RCN-TC-5AW-E2, -E3
Clasa Energetică (Răcire/Încălzire)			A++/A+
SEER			6.49
SCOP (Climat temperat)			4.30
Pdesign (răcire/încălzire(@-10°C))		kW	5.0/4.3
Consumul anual de electricitate (răcire/încălzire)		kWh/a	270/1402
Performanța pe modul încălzire			Climat temperat

Schema tehnica

Datorită politicii de continuă îmbunătățire a produselor, ne rezervăm dreptul de a modifica specificațiile tehnice fără nicio notificare prealabilă.



TEMPERATURE CONTROL FOR TODAY & TOMORROW



■ DIMENSIONS (Unit:mm) - FDTC -

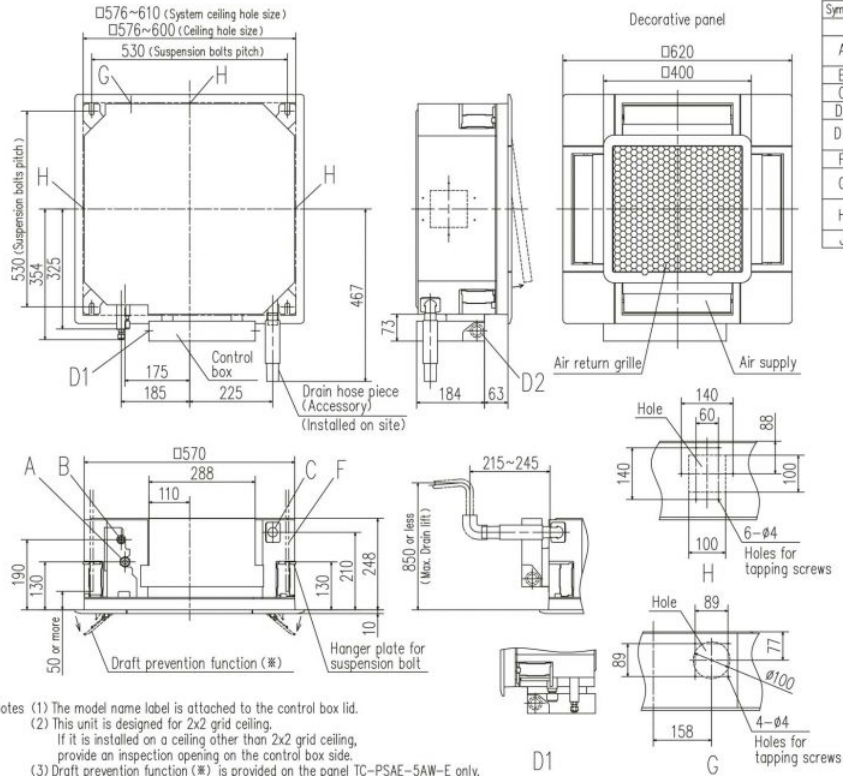

Symbol	Content		
	Model	25,35	40,50,60
A	Gas piping	φ9.52 (3/8") (Flare)	φ12.7 (1/2") (Flare)
B	Liquid piping	φ6.35 (1/4") (Flare)	
C	Drain piping	VP25 (O.D.32)	
D1	Power supply connection		
D2	Remote control code and signal wiring connection		
F	Suspension bolts	(M10 or M8)	
G	Outside air opening for ducting	(Knock out)	
H	Air outlet opening for ducting	φ125 (Knock out)	
J	Inspection opening	450X450	

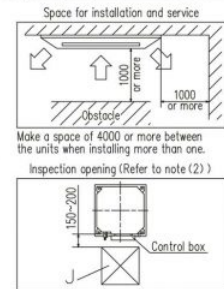

- Notes (1) The model name label is attached to the control box lid.
 (2) This unit is designed for 2x2 grid ceiling. If it is installed on a ceiling other than 2x2 grid ceiling, provide an inspection opening on the control box side.
 (3) Draft prevention function (※) is provided on the panel TC-PSAE-5AW-E only.

Datorită politicii de continuă îmbunătățire a produselor, ne rezervăm dreptul de a modifica specificațiile tehnice fără nicio notificare prealabilă.



TEMPERATURE CONTROL FOR TODAY & TOMORROW



SRC40ZSX-W1, 50ZSX-W1, 60ZSX-W1 SRC40ZSX-S, 50ZSX-S, 60ZSX-S

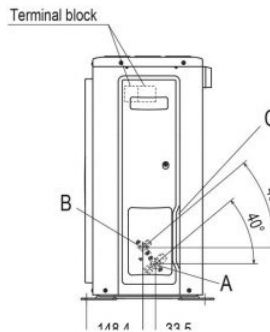
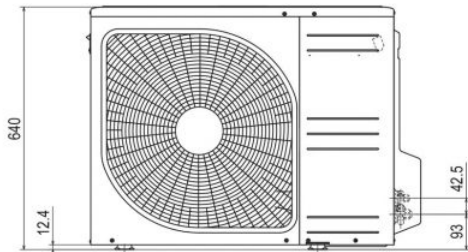
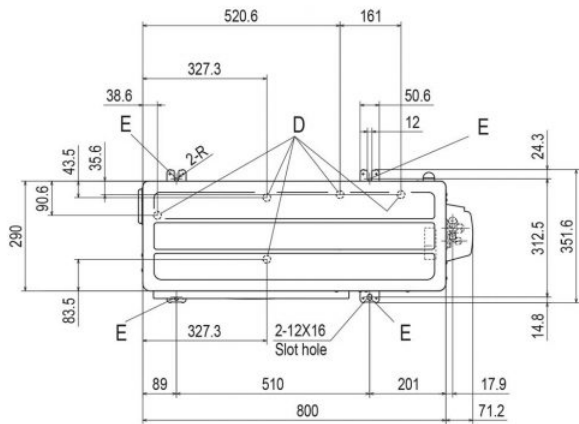

Symbol	Content	
A	Service valve connection (Gas side)	φ 12.7(1/2")(Flare)
B	Service valve connection (Liquid side)	φ 6.35(1/4")(Flare)
C	Pipe/cable draw-out hole	
D	Drain discharge hole	φ 20×5 places
E	Anchor bolt hole	M10-12×4 places

Notes

- (1) The unit must not be surrounded by walls on the four sides.
- (2) The unit must be fixed with anchor bolts. An anchor bolt must not protrude more than 15mm.
- (3) If the unit is installed in the location where there is a possibility of strong winds, place the unit such that the direction of air from the outlet gets perpendicular to the wind direction.
- (4) Leave 200mm or more space above the unit.
- (5) The wall height on the outlet side should be 1200mm or less.
- (6) The model name label is attached on the front side of the unit.

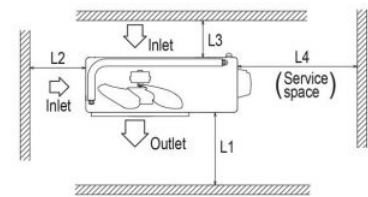

Minimum installation space

Examples installation Size	Minimum installation space			
	I	II	III	IV
L1	Open	280	280	180
L2	100	75	Open	Open
L3	100	80	80	80
L4	250	Open	250	Open

Datorită politicii de continuă îmbunătățire a produselor, ne rezervăm dreptul de a modifica specificațiile tehnice fără nicio notificare prealabilă.