



TEMPERATURE CONTROL
FOR **TODAY & TOMORROW**

MITSUBISHI
HEAVY INDUSTRIES

FDU100VSXWVH

Capacitate nominala de racire: **10.0 KW**



Poze unitate interna si unitate externa



Specificatii

Unitate internă		FDU100VH	
Unitate externă		FDC100VSX-W	
Sursă de alimentare		Trifazic 380-415V, 50Hz / 380V, 60Hz	
Capacitate nominală de răcire (Min~Max)		kW	10.0 (3.5 ~ 11.2)
Capacitate nominală de încălzire (Min~Max)		kW	11.2 (2.7 ~ 16.0)
Consum de energie	Răcire/Încălzire	kW	2.59 / 2.63
EER/COP	Răcire/Încălzire		3.86 / 4.26



TEMPERATURE CONTROL FOR TODAY & TOMORROW



Curent de intrare			A	5
Amperaj maxim			A	15
Nivel putere sonoră*1	U.I. *3	Răcire/Încălzire	dB(A)	65 / 65
	U.E.	Răcire/Încălzire		67 / 67
Nivel presiune sonoră*1	U.I. *3	Răcire (Hi/Me/Lo/Ulo)		44 / 38 / 36 / 30
		Încălzire (Hi/Me/Lo/Ulo)		44 / 38 / 36 / 30
	U.E.	Răcire/Încălzire		53 / 51
Flux de aer	U.I. *3	Răcire (Hi/Me/Lo/Ulo)	m ³ /min	36 / 28 / 25 / 19
		Încălzire (Hi/Me/Lo/Ulo)		36 / 28 / 25 / 19
	U.E.	Răcire/Încălzire		100 / 100
Presiune statică externă disponibilă			Pa	Standard:60 Max:200
Dimensiuni exterioare	U.I.	Înălțime / Lățime / Adâncime	mm	280 x 1,370 x 740
	U.E.			1,300 x 970 x 370
Greutate netă	U.I. / U.E.		kg	54 / 99
Refrigerant		Tip/GWP		R32/675
Refrigerant		Încărcare	kg/TCO ₂ Eq	4.0/2.7
Dimensiuni țevă refrigerant		Lichid/Gaz	mm/ø	9.52(3/8") / 15.88(5/8")
Lungime țevă refrigerant (o direcție)			m	Max.100

Datorită politicii de continuă îmbunătățire a produselor, ne rezervăm dreptul de a modifica specificațiile tehnice fără nicio notificare prealabilă.



TEMPERATURE CONTROL FOR TODAY & TOMORROW



Diferență de nivel suportată	Unitate externă este mai sus/mai jos	m	Max.50 / Max.15
Interval de funcționare - temperatură exterioară	Răcire*2	°C	-15~50
	Încălzire		-20~20
Filtru de aer (cantitate)			Discutați cu un specialist ATX
Telecomandă (opțional)			Cu fir:RC-EX3A, RC-E5, RCH-E3 Wireless:RCN-KIT4-E2
Clasa Energetică (Răcire/Încălzire)			A++/A+
SEER			6.29
SCOP (Climat temperat)			4.13
Pdesign (răcire/încălzire(@-10°C))		kW	10.0/11.2
Consumul anual de electricitate (răcire/încălzire)		kWh/a	557/3800
Performanța pe modul încălzire			Climat temperat

Schema tehnica

Datorită politicii de continuă îmbunătățire a produselor, ne rezervăm dreptul de a modifica specificațiile tehnice fără nicio notificare prealabilă.



TEMPERATURE CONTROL FOR TODAY & TOMORROW



Models FDU100VH,125VH,140VH

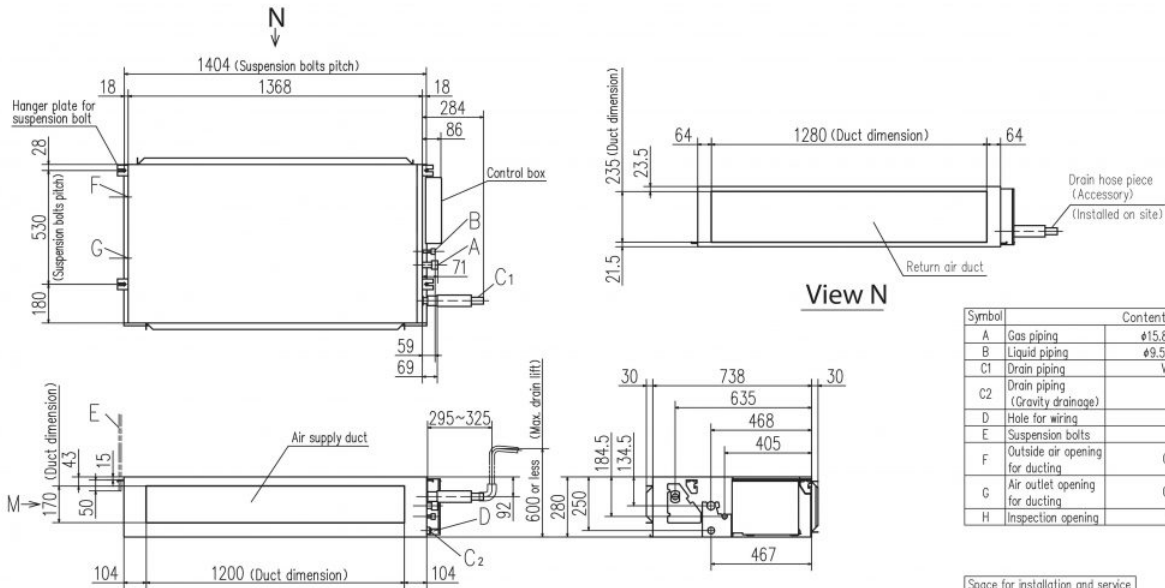

Symbol	Content
A	Gas piping $\phi 15.88$ (5/8") (Flare)
B	Liquid piping $\phi 9.52$ (3/8") (Flare)
C1	Drain piping VP25 (O.D.32)
C2	Drain piping (Gravity drainage) VP20
D	Hole for wiring
E	Suspension bolts M10
F	Outside air opening for ducting (Knock out)
G	Air outlet opening for ducting (Knock out)
H	Inspection opening (450X450)

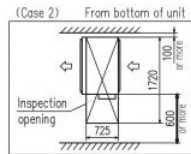
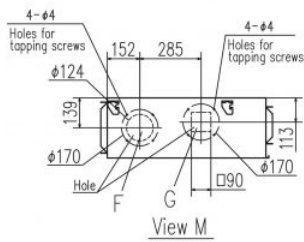

Note (1) The model name label is attached on the lid of the control box.

Space for installation and service

Select either of two cases to keep space for installation and services.
(Case 1) From side of unit

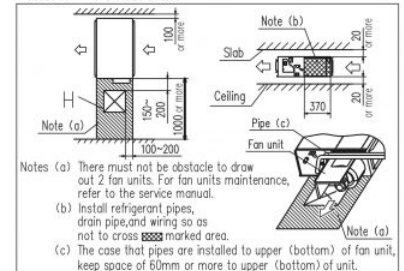

Datorită politicii de continuă îmbunătățire a produselor, ne rezervăm dreptul de a modifica specificațiile tehnice fără nicio notificare prealabilă.



TEMPERATURE CONTROL FOR TODAY & TOMORROW



FDC100VN-X-W, 125VN-X-W, 140VN-X-W, 100VS-X-W, 125VS-X-W, 140VS-X-W

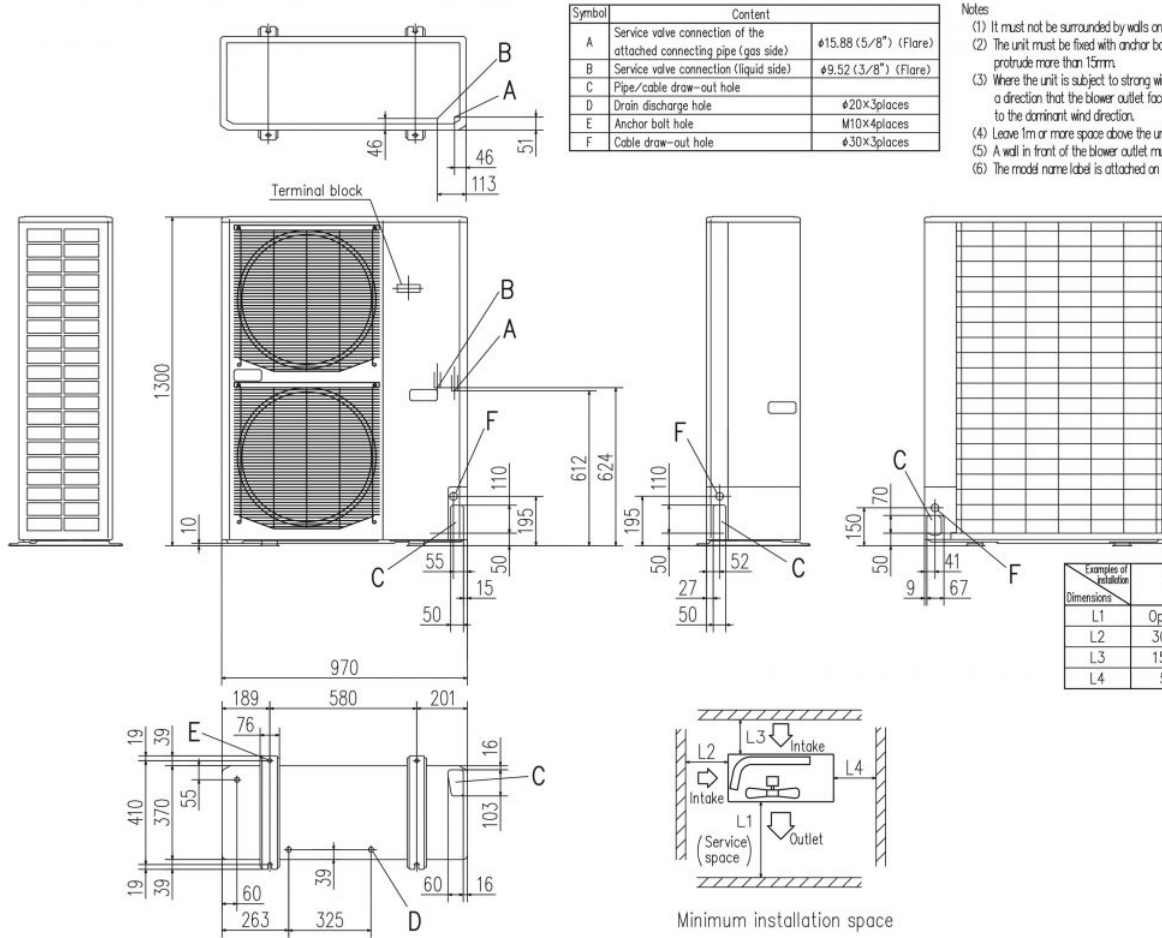

- Notes
- (1) It must not be surrounded by walls on the four sides.
 - (2) The unit must be fixed with anchor bolts. An anchor bolt must not protrude more than 15mm.
 - (3) Where the unit is subject to strong winds, lay it in such a direction that the blower outlet faces perpendicularly to the dominant wind direction.
 - (4) Leave 1m or more space above the unit.
 - (5) A wall in front of the blower outlet must not exceed the units height.
 - (6) The model name label is attached on the lower right corner of the front panel.

Minimum installation space

Datorită politicii de continuă îmbunătățire a produselor, ne rezervăm dreptul de a modifica specificațiile tehnice fără nicio notificare prealabilă.