



TEMPERATURE CONTROL
FOR **TODAY & TOMORROW**

MITSUBISHI
HEAVY INDUSTRIES

FDU71VNPVH

Capacitate nominala de racire: **7.1 KW**



Poze unitate interna si unitate externa



Specificatii

Unitate internă		FDU71VH	
Unitate externă		FDC71VNP	
Sursă de alimentare		Monofazic 220-240V, 50Hz / 220V, 60Hz	
Capacitate nominală de răcire (Min~Max)		kW	7.1 (1.4 ~ 7.1)
Capacitate nominală de încălzire (Min~Max)		kW	7.1 (1.0 ~ 7.1)
Consum de energie	Răcire/Încălzire	kW	2.60 / 1.89
EER/COP	Răcire/Încălzire		2.73. / 3.76



TEMPERATURE CONTROL FOR TODAY & TOMORROW



Curent de intrare			A	5
Amperaj maxim			A	14.5
Nivel putere sonoră*1	U.I. *3	Răcire/Încălzire	dB(A)	65 / 65
	U.E.	Răcire/Încălzire		67 / 67
Nivel presiune sonoră*1	U.I. *3	Răcire (Hi/Me/Lo/Ulo)		38 / 33 / 29 / 25
		Încălzire (Hi/Me/Lo/Ulo)	38 / 33 / 29 / 25	
	U.E.	Răcire/Încălzire	54 / 54	
Flux de aer	U.I. *3	Răcire (Hi/Me/Lo/Ulo)	m ³ /min	24 / 19 / 15 / 10
		Încălzire (Hi/Me/Lo/Ulo)		24 / 19 / 15 / 10
	U.E.	Răcire/Încălzire		36 / 36
Presiune statică externă disponibilă			Pa	Standard:35 Max:200
Dimensiuni exterioare	U.I.	Înălțime / Lățime / Adâncime	mm	280 x 950 x 635
	U.E.			640 x 800(+71) x 290
Greutate netă	U.I. / U.E.		kg	34 / 45
Refrigerant		Tip/GWP		R410A/2088
Refrigerant		Încărcare	kg/TCO ₂ Eq	1.6/3.341
Dimensiuni țeavă refrigerant		Lichid/Gaz	mm/ø	6.35(1/4") / 12.7(1/2")
Lungime țeavă refrigerant (o direcție)			m	Max.30

Datorită politicii de continuă îmbunătățire a produselor, ne rezervăm dreptul de a modifica specificațiile tehnice fără nicio notificare prealabilă.



TEMPERATURE CONTROL FOR TODAY & TOMORROW



Diferență de nivel suportată	Unitate externă este mai sus/mai jos	m	Max.20 / Max.20
Interval de funcționare - temperatură exterioară	Răcire*2	°C	-15~46
	Încălzire		-15~20
Filtru de aer (cantitate)			Discutați cu un specialist ATX
Telecomandă (opțional)			Cu fir:RC-EX3A, RC-E5, RCH-E3 Wireless:RCN-KIT4-E2
Clasa Energetică (Răcire/Încălzire)			A+/A+
SEER			5.73
SCOP (Climat temperat)			4.00
Pdesign (răcire/încălzire(@-10°C))	kW		7.1/5.7
Consumul anual de electricitate (răcire/încălzire)	kWh/a		434/1997
Performanța pe modul încălzire			Climat temperat

Schema tehnica

Datorită politicii de continuă îmbunătățire a produselor, ne rezervăm dreptul de a modifica specificațiile tehnice fără nicio notificare prealabilă.



TEMPERATURE CONTROL FOR TODAY & TOMORROW



Model FDU71VH

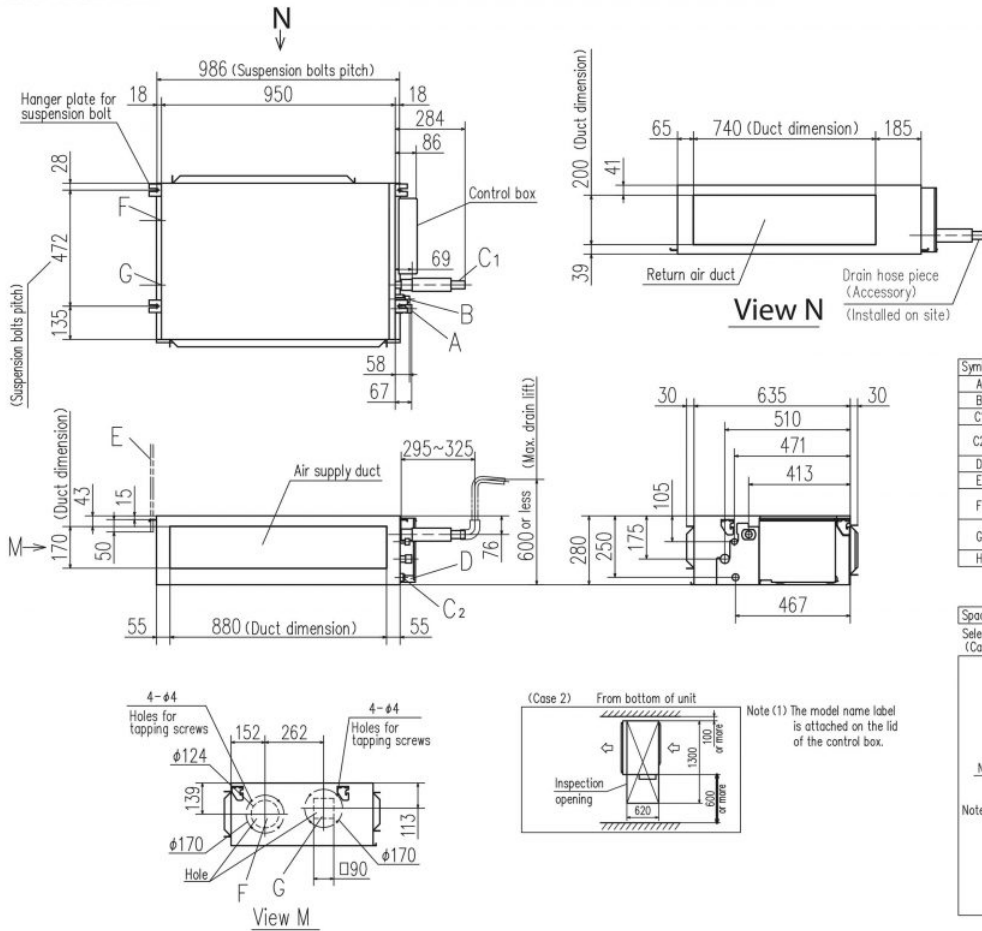

Symbol	Content
A	Gas piping φ15.88 (5/8") (Flare)
B	Liquid piping φ9.52 (3/8") (Flare)
C1	Drain piping VP25 (O.D.32)
C2	Drain piping (Gravity drainage) VP20
D	Hole for wiring
E	Suspension bolts M10
F	Outside air opening for ducting (Knock out)
G	Air outlet opening for ducting (Knock out)
H	Inspection opening (450x450)

Space for installation and service
Select either of two cases to keep space for installation and services.
(Case 1) From side of unit

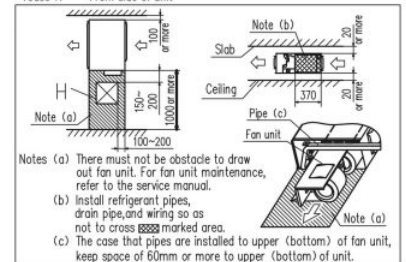

Datorită politicii de continuă îmbunătățire a produselor, ne rezervăm dreptul de a modifica specificațiile tehnice fără nicio notificare prealabilă.



TEMPERATURE CONTROL FOR TODAY & TOMORROW



FDC71VNP

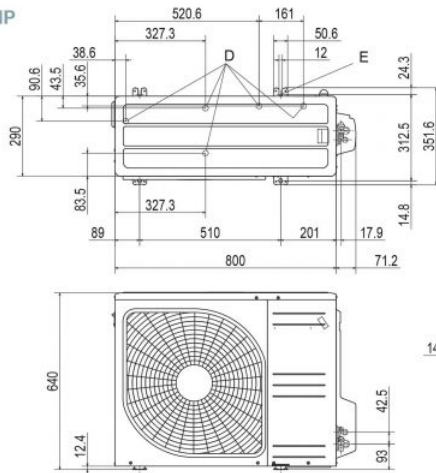

Symbol	Content
A	Service valve connection (gas side) $\phi 12.7(1/2)$ (Flare)
B	Service valve connection (liquid side) $\phi 8.35(1/4)$ (Flare)
C	Pipe/cable draw-out hole
D	Drain discharge hole $\phi 20 \times 5$ places
E	Anchor bolt hole $M10 \times 4$ places

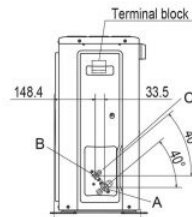

Notes

- (1) It must not be surrounded by walls on the four sides.
- (2) The unit must be fixed with anchor bolts. An anchor bolt must not protrude more than 15mm.
- (3) Where the unit is subject to strong winds, lay it in such a direction that the blower outlet faces perpendicularly to the dominant wind direction.
- (4) Leave 1m or more space above the unit.
- (5) A wall in front of the blower outlet must not exceed the units height.
- (6) The model name label is attached on the lower right corner of the front panel.

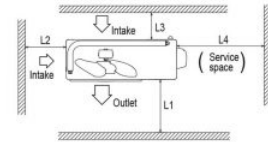

Minimum installation space

Examples of Dimensions	Installation			
	I	II	III	IV
L1	Open	280	280	180
L2	100	75	Open	Open
L3	100	80	80	80
L4	250	Open	250	Open

Datorită politicii de continuă îmbunătățire a produselor, ne rezervăm dreptul de a modifica specificațiile tehnice fără nicio notificare prealabilă.