



TEMPERATURE CONTROL
FOR **TODAY & TOMORROW**

MITSUBISHI
HEAVY INDUSTRIES

FDUM100VNPWVH

Capacitate nominala de racire: **10.0 KW**



Poze unitate interna si unitate externa



Specificatii

Unitate internă			FDUM100VH
Unitate externă			FDC100VNP-W
Sursă de alimentare			Monofazic 220-240V, 50Hz / 220V, 60Hz
Capacitate nominală de răcire (Min~Max)		kW	10.0 (2.1 ~ 10.2)
Capacitate nominală de încălzire (Min~Max)		kW	10.0 (1.7 ~ 10.4)
Consum de energie	Răcire/Încălzire	kW	3.08 / 2.45
EER/COP	Răcire/Încălzire		3.25 / 4.08



TEMPERATURE CONTROL FOR TODAY & TOMORROW



Curent de intrare			A	5
Amperaj maxim			A	19
Nivel putere sonoră*1	U.I. *3	Răcire/Încălzire	dB(A)	65 / 65
	U.E.	Răcire/Încălzire		68 / 67
Nivel presiune sonoră*1	U.I. *3	Răcire (Hi/Me/Lo/Ulo)		44 / 38 / 36 / 30
		Încălzire (Hi/Me/Lo/Ulo)		44 / 38 / 36 / 30
	U.E.	Răcire/Încălzire		56 / 54
Flux de aer	U.I. *3	Răcire (Hi/Me/Lo/Ulo)	m ³ /min	36 / 28 / 25 / 19
		Încălzire (Hi/Me/Lo/Ulo)		36 / 28 / 25 / 19
	U.E.	Răcire/Încălzire		63 / 55
Presiune statică externă disponibilă			Pa	Standard:60 Max:100
Dimensiuni exterioare	U.I.	Înălțime / Lățime / Adâncime	mm	280 x 1,370 x 740
	U.E.			750 Å 880(+88) Å 340
Greutate netă	U.I. / U.E.		kg	54 / 57
Refrigerant		Tip/GWP		R32/675
Refrigerant		Încărcare	kg/TCO ₂ Eq	1.7/1.148
Dimensiuni țevă refrigerant		Lichid/Gaz	mm/ø	6.35(1/4") / 15.88(5/8")
Lungime țevă refrigerant (o direcție)			m	Max.30

Datorită politicii de continuă îmbunătățire a produselor, ne rezervăm dreptul de a modifica specificațiile tehnice fără nicio notificare prealabilă.



TEMPERATURE CONTROL FOR TODAY & TOMORROW



Diferență de nivel suportată	Unitate externă este mai sus/mai jos	m	Max.20 / Max.20
Interval de funcționare - temperatură exterioară	Răcire*2	°C	-15~46
	Încălzire		-15~20
Filtru de aer (cantitate)			(Opțional) Kit filtru : UM-FL3EF
Telecomandă (opțional)			Cu fir:RC-EX3A, RC-E5, RCH-E3 Wireless:RCN-KIT4-E2
Clasa Energetică (Răcire/Încălzire)			A++/A+
SEER			6.11
SCOP (Climat temperat)			4.13
Pdesign (răcire/încălzire(@-10°C))	kW		10.0/6.4
Consumul anual de electricitate (răcire/încălzire)	kWh/a		573/2169
Performanța pe modul încălzire			Climat temperat

Schema tehnica

Datorită politicii de continuă îmbunătățire a produselor, ne rezervăm dreptul de a modifica specificațiile tehnice fără nicio notificare prealabilă.



TEMPERATURE CONTROL FOR TODAY & TOMORROW



Models FDUM100VH,125VH,140VH

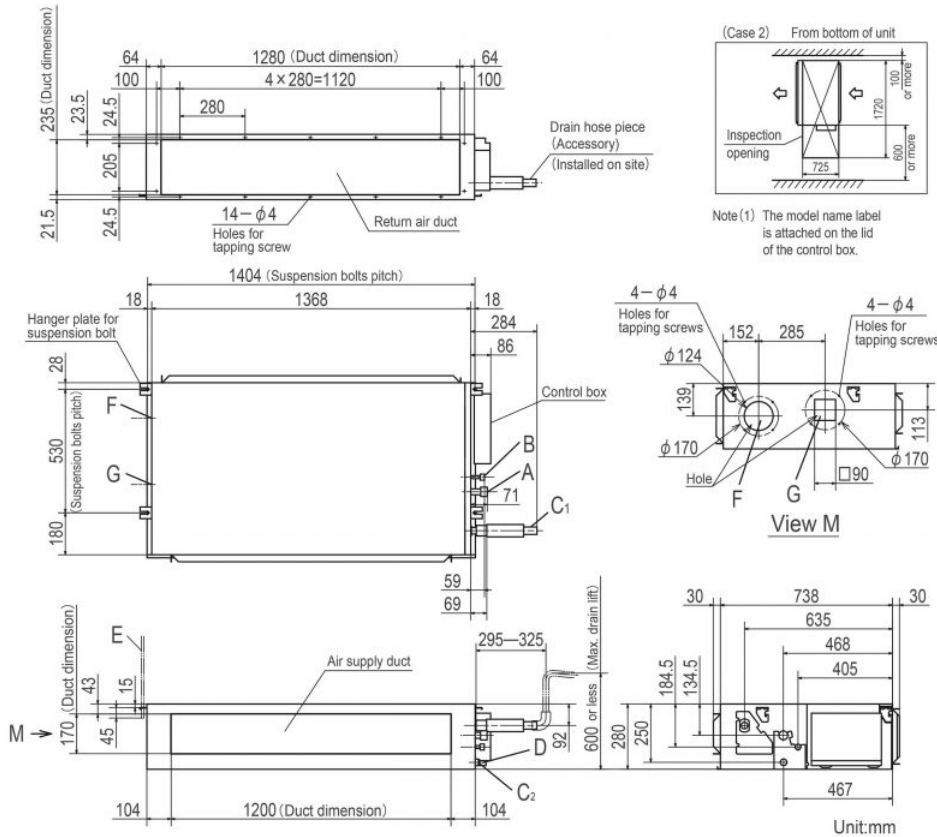

Symbol	Content
A	Gas piping φ 15.88 (5/8") (Flare)
B	Liquid piping φ 9.52 (3/8") (Flare)
C ₁	Drain piping VP25 (O.D.32)
C ₂	Drain piping (Gravity drainage) VP20
D	Hole for wiring
E	Suspension bolts (M10)
F	Outside air opening for ducting (φ 150) (Knock out)
G	Air outlet opening for ducting (φ 125) (Knock out)
H	Inspection opening (450×450)

Space for installation and service

Select either of two cases to keep space for installation and services.
(Case 1) From side of unit

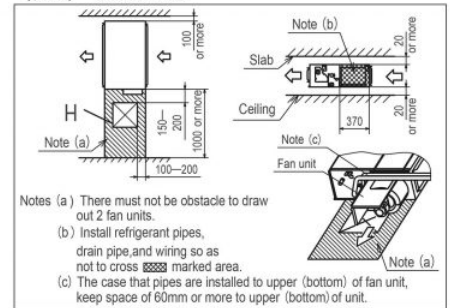

Datorită politicii de continuă îmbunătățire a produselor, ne rezervăm dreptul de a modifica specificațiile tehnice fără nicio notificare prealabilă.



TEMPERATURE CONTROL FOR TODAY & TOMORROW



FDC90VNP-W, 100VNP-W
FDC90VNP1

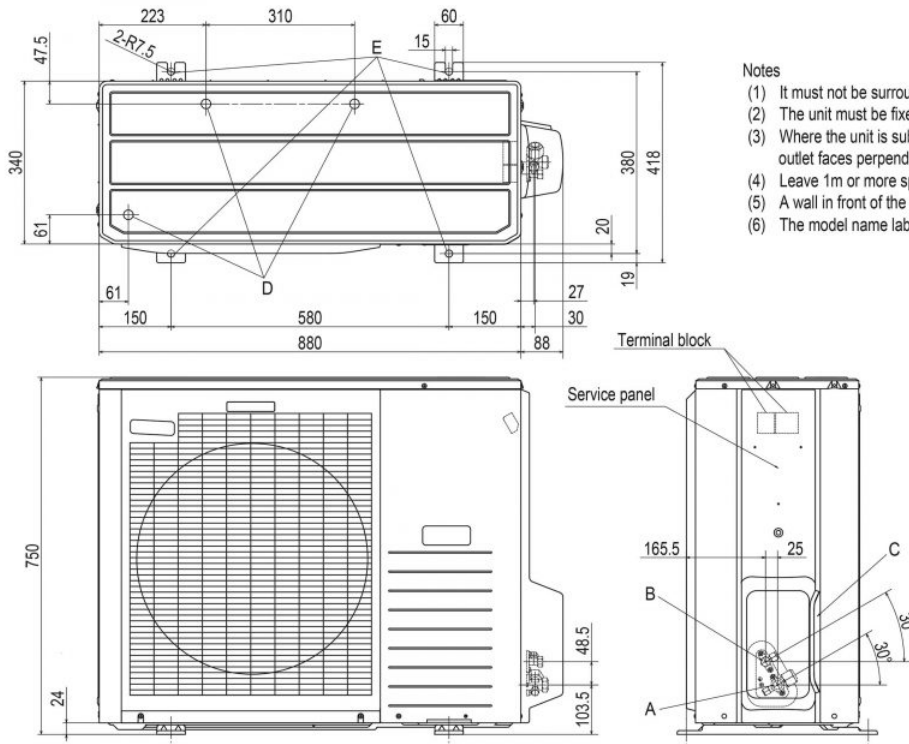

Notes

- (1) It must not be surrounded by walls on four sides.
- (2) The unit must be fixed with anchor bolts. An anchor bolt must not protrude more than 15mm.
- (3) Where the unit is subjected to strong winds, lay it in such a direction that the blower outlet faces perpendicularly to the dominant wind direction.
- (4) Leave 1m or more space above the unit.
- (5) A wall in front of the blower outlet must not exceed the unit's height.
- (6) The model name label is attached on the lower right corner of the front panel.

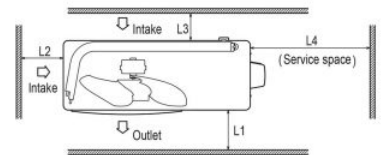

Minimum installation space

Examples of installation Dimensions	I			II		III
	Open	Open	Open	Open	Open	500
L1	Open	Open	Open	Open	Open	500
L2	300	250	250	Open	Open	Open
L3	100	150	150	100	100	100
L4	250	250	250	250	250	250

Symbol	Content	
A	Service valve connection (gas side)	φ 15.88(5/8") (Flare)
B	Service valve connection (liquid side)	φ 6.35(1/4") (Flare)
C	Pipe / cable draw-out hole	
D	Drain discharge hole	φ 20 x 3 places
E	Anchor bolt hole	M10 x 4 places

Datorită politicii de continuă îmbunătățire a produselor, ne rezervăm dreptul de a modifica specificațiile tehnice fără nicio notificare prealabilă.