



TEMPERATURE CONTROL
FOR TODAY & TOMORROW

MITSUBISHI
HEAVY INDUSTRIES

FDUM100VSAWPVH

Capacitate nominala de racire: **10.0 KW**



Poze unitate interna si unitate externa



Specificatii

Unitate internă		FDUM50VH x 2	
Unitate externă		FDC100VSA-W	
Sursă de alimentare		Trifazic 380-415V, 50Hz / 380V, 60Hz	
Capacitate nominală de răcire (Min-Max)		kW	10.0 (4.0 ~ 11.2)
Capacitate nominală de încălzire (Min-Max)		kW	11.2 (4.0 ~ 12.5)
Power Consumption	Răcire/Încălzire	kW	3.25 / 3.04
EER/COP	Răcire/Încălzire	kW	3.08 / 3.68



TEMPERATURE CONTROL FOR TODAY & TOMORROW



Curent de intrare			A	5
Max. current			A	17
Nivel putere sonoră*1	U.I.*3	Răcire/Încălzire	dB(A)	60 / 60
	U.E.	Răcire/Încălzire		69 / 70
Nivel presiune sonoră*1	U.I.*3	Răcire (P-Hi/Hi/Me/Lo)		37 / 32 / 29 / 26
		Încălzire (P-Hi/Hi/Me/Lo)		37 / 32 / 29 / 26
	U.E.	Răcire/Încălzire		54 / 55
Flux de aer	U.I.*3	Răcire (P-Hi/Hi/Me/Lo)	m ³ /min	13 / 10 / 9 / 8
		Încălzire (P-Hi/Hi/Me/Lo)		13 / 10 / 9 / 8
	U.E.	Răcire/Încălzire		75 / 73
Presiune statică externă			Pa	Standard:35 Max:100
Exterior dimensions	U.I.	HeightxWidthxDepth	mm	280 x 750 x 635
	U.E.		mm	845 x 970 x 370
Greutate netă		U.I./U.E.	kg	29 / 78
Refrigerant charge			kg/TCO ₂ E	3.3/2.228
Refrigerant Type GWP				R32/675
Ref.piping size	Lichid/Gaz		Ț, mm	9.52(3/8") / 15.88(5/8")
Lungime țeavă refrigerant (o direcție)			m	Max.50
Diferență de nivel suportată	Unitate externă este mai sus/mai jos		m	Max.50 / Max.15

Datorită politicii de continuă îmbunătățire a produselor, ne rezervăm dreptul de a modifica specificațiile tehnice fără nicio notificare prealabilă.



TEMPERATURE CONTROL FOR TODAY & TOMORROW



Interval de funcționare - temperatură exterioară	Răcire*2	°C	-15~50
	Încălzire	°C	-20~20
Filtru de aer, cantitate			(Opțional) Kit filtru : UM- FL1EF
Telecomandă (opțional)			Cu fir:RC-EX3A, RC-E5, RCH-E3 Wireless:RCN- KIT4-E2
Clasa Energetică (Răcire/Încălzire)			A+/A+
SEER			5.82
SCOP (Climat temperat)			4.00
Pdesign (răcire/încălzire(@-10°C))			10.0/8.5
Annual Electricity Consumption			602/2974
Performanța pe modul încălzire			Climat temperat

Schema tehnica

Datorită politicii de continuă îmbunătățire a produselor, ne rezervăm dreptul de a modifica specificațiile tehnice fără nicio notificare prealabilă.



TEMPERATURE CONTROL FOR TODAY & TOMORROW



FDUM50VH

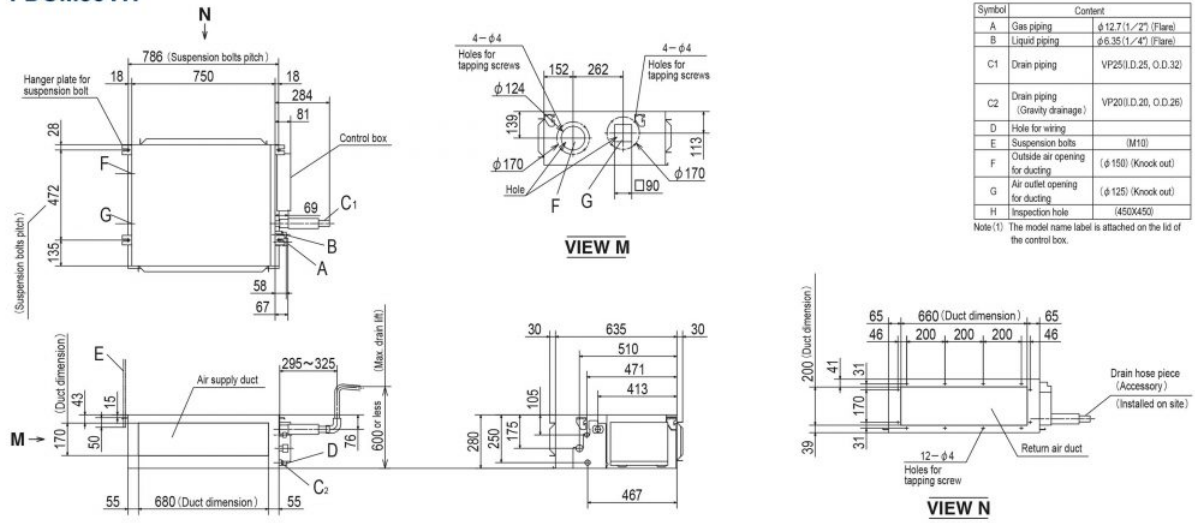

Datorită politicii de continuă îmbunătățire a produselor, ne rezervăm dreptul de a modifica specificațiile tehnice fără nicio notificare prealabilă.



TEMPERATURE CONTROL FOR TODAY & TOMORROW



FDC100VNA-W, 125VNA-W, 140VNA-W, 100VSA-W, 125VSA-W, 140VSA-W
FDC100VNA, 125VNA, 140VNA, 100VSA, 125VSA, 140VSA

Symbol	Content	
A	Service valve connection (gas side)	φ15.88 (5/8") (Flare)
B	Service valve connection (liquid side)	φ9.52 (3/8") (Flare)
C	Pipe/cable draw-out hole	
D	Drain discharge hole	φ20×3places
E	Anchor bolt hole	M10×4places
F	Cable draw-out hole	φ30×3places

Notes

- (1) It must not be surrounded by walls on the four sides.
- (2) The unit must be fixed with anchor bolts. An anchor bolt must not protrude more than 15mm.
- (3) Where the unit is subject to strong winds, lay it in such a direction that the blower outlet faces perpendicularly to the dominant wind direction.
- (4) Leave 1m or more space above the unit.
- (5) A wall in front of the blower outlet must not exceed the units height.
- (6) The model name label is attached on the lower right corner of the front panel.

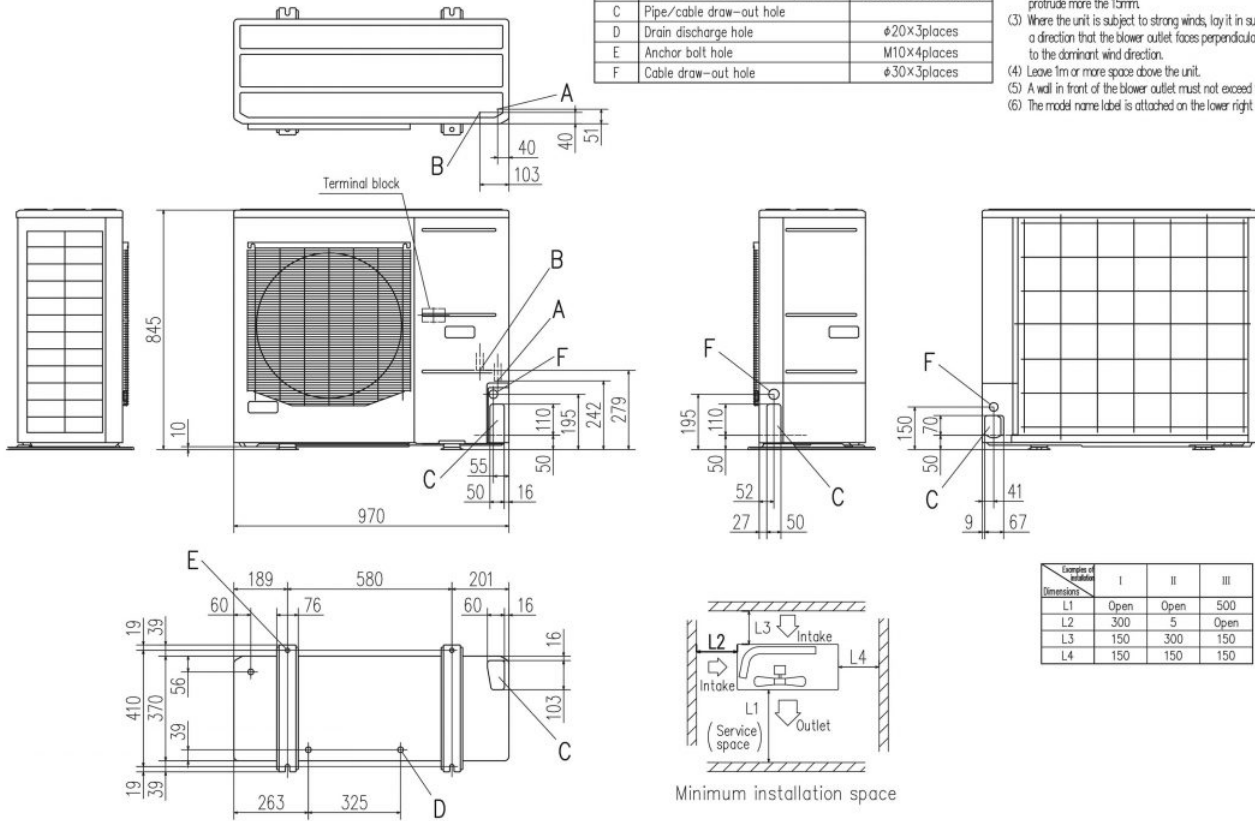

Datorită politicii de continuă îmbunătățire a produselor, ne rezervăm dreptul de a modifica specificațiile tehnice fără nicio notificare prealabilă.