



TEMPERATURE CONTROL
FOR **TODAY & TOMORROW**

MITSUBISHI
HEAVY INDUSTRIES

FDUM100VSXPVH

Capacitate nominala de racire: **10.0 KW**



Poze unitate interna si unitate externa



Specificatii

Unitate internă		FDUM50VH x 2	
Unitate externă		FDC100VSX	
Sursă de alimentare		Trifazic 380-415V, 50Hz / 380V, 60Hz	
Capacitate nominală de răcire (Min-Max)		kW	10.0 (4.0 ~ 11.2)
Capacitate nominală de încălzire (Min-Max)		kW	11.2 (4.0 ~ 16.0)
Power Consumption	Răcire/Încălzire	kW	2.66 / 3.02
EER/COP	Răcire/Încălzire	kW	3.76 / 3.71



TEMPERATURE CONTROL FOR TODAY & TOMORROW



Curent de intrare			A	5
Max. current			A	15
Nivel putere sonoră*1	U.I.*3	Răcire/Încălzire	dB(A)	60 / 60
	U.E.	Răcire/Încălzire		70 / 70
Nivel presiune sonoră*1	U.I.*3	Răcire (P-Hi/Hi/Me/Lo)		37 / 32 / 29 / 26
		Încălzire (P-Hi/Hi/Me/Lo)		37 / 32 / 29 / 26
	U.E.	Răcire/Încălzire		48 / 50
Flux de aer	U.I.*3	Răcire (P-Hi/Hi/Me/Lo)	m ³ /min	13 / 10 / 9 / 8
		Încălzire (P-Hi/Hi/Me/Lo)		13 / 10 / 9 / 8
	U.E.	Răcire/Încălzire		100 / 100
Presiune statică externă			Pa	Standard:35 Max:100
Exterior dimensions	U.I.	HeightxWidthxDepth	mm	280 x 750 x 635
	U.E.		mm	1,300 x 970 x 370
Greutate netă		U.I./U.E.	kg	29 / 105
Refrigerant charge			kg/TCO ₂ E	4.5/9.396
Refrigerant Type GWP				R410A/2088
Ref.piping size	Lichid/Gaz		Ț, mm	9.52(3/8") / 15.88(5/8")
Lungime țeavă refrigerant (o direcție)			m	Max.100
Diferență de nivel suportată	Unitate externă este mai sus/mai jos		m	Max.30 / Max.15

Datorită politicii de continuă îmbunătățire a produselor, ne rezervăm dreptul de a modifica specificațiile tehnice fără nicio notificare prealabilă.



TEMPERATURE CONTROL FOR TODAY & TOMORROW



Interval de funcționare - temperatură exterioară	Răcire*2	°C	-15~43
	Încălzire	°C	-20~20
Filtru de aer, cantitate			(Opțional) Kit filtru : UM- FL1EF
Telecomandă (opțional)			Cu fir:RC-EX3A, RC-E5, RCH-E3 Wireless:RCN- KIT4-E2
Clasa Energetică (Răcire/Încălzire)			A/A
SEER			5.14
SCOP (Climat temperat)			3.88
Pdesign (răcire/încălzire(@-10°C))			10.0/10.0
Annual Electricity Consumption			681/3606
Performanța pe modul încălzire			Climat temperat

Schema tehnica

Datorită politicii de continuă îmbunătățire a produselor, ne rezervăm dreptul de a modifica specificațiile tehnice fără nicio notificare prealabilă.



TEMPERATURE CONTROL FOR TODAY & TOMORROW



Models FDUM40VH, FDUM50VH

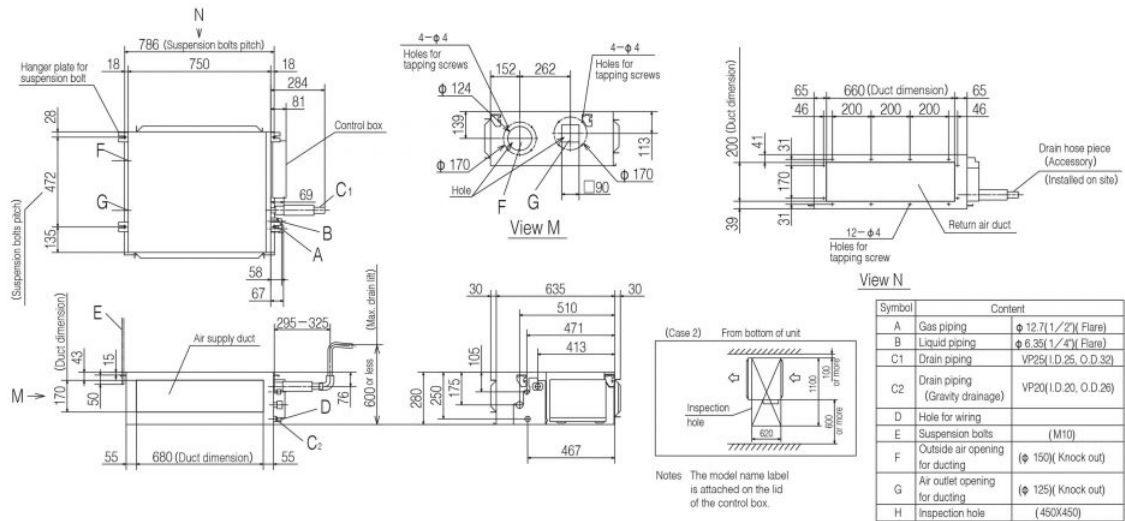

Datorită politicii de continuă îmbunătățire a produselor, ne rezervăm dreptul de a modifica specificațiile tehnice fără nicio notificare prealabilă.



TEMPERATURE CONTROL FOR TODAY & TOMORROW



FDC100VNX, 100VSX, 125VNX, 125VSX,
140VNX, 140VSX

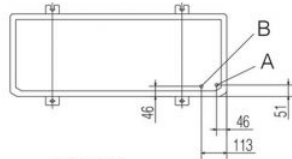

Symbol	Content
A	Service valve connection of the attached connecting pipe (gas side) φ 15.88 (5/8") (Flare)
B	Service valve connection (liquid side) φ 9.52 (3/8") (Flare)
C	Pipe / cable draw-out hole
D	Drain discharge hole φ 20 x 3places
E	Anchor bolt hole M10 x 4places
F	Cable draw-out hole φ 30 (front) φ 45 (side) φ 50 (back)

Notes

- (1) It must not be surrounded by walls on the four sides.
- (2) The unit must be fixed with anchor bolts. An anchor bolt must not protrude more than 15mm.
- (3) Where the unit is subject to strong winds, lay it in such a direction that the blower outlet faces perpendicularly to the dominant wind direction.
- (4) Leave 1m or more space above the unit.
- (5) A wall in front of the blower outlet must not exceed the unit's height.
- (6) The model name label is attached on the lower right corner of the front panel.
- (7) Connect the Service valve with local pipe by using the pipe of the attachment. (Gas side only)

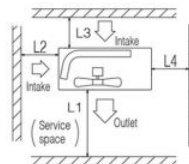
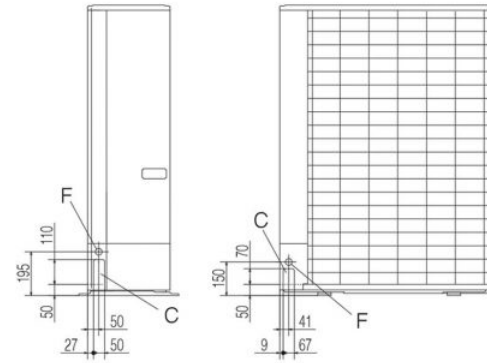
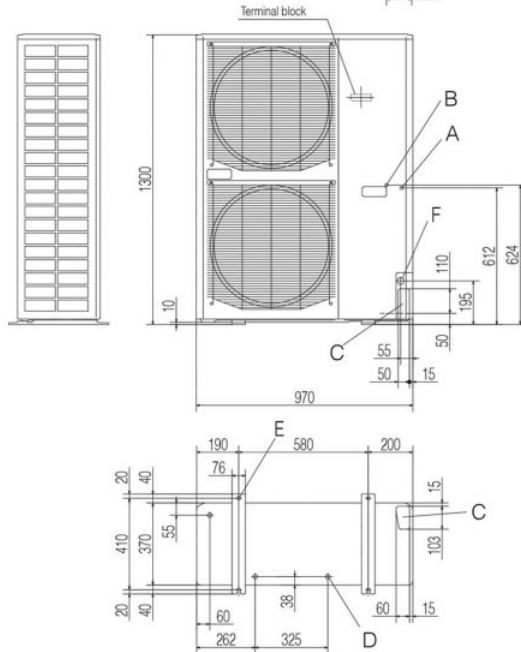

Minimum installation space

Examples of Dimensions	Examples of Installation		
	I	II	III
L1	Open	Open	500
L2	300	5	Open
L3	150	300	150
L4	5	5	5

Datorită politicii de continuă îmbunătățire a produselor, ne rezervăm dreptul de a modifica specificațiile tehnice fără nicio notificare prealabilă.