



TEMPERATURE CONTROL
FOR TODAY & TOMORROW

mitsubishi
HEAVY INDUSTRIES

FDUM100VSXWPVH

Capacitate nominala de racire: **10.0 KW**



Poze unitate interna si unitate externa



Specificatii

Unitate internă		FDUM50VH x 2	
Unitate externă		FDC100VSX-W	
Sursă de alimentare		Trifazic 380-415V, 50Hz / 380V, 60Hz	
Capacitate nominală de răcire (Min-Max)		kW	10.0 (3.5 ~ 11.2)
Capacitate nominală de încălzire (Min-Max)		kW	11.2 (2.7 ~ 16.0)
Power Consumption	Răcire/Încălzire	kW	2.66 / 2.96
EER/COP	Răcire/Încălzire	kW	3.76 / 3.79



TEMPERATURE CONTROL FOR TODAY & TOMORROW



Curent de intrare			A	5
Max. current			A	15
Nivel putere sonoră*1	U.I.*3	Răcire/Încălzire	dB(A)	60 / 60
	U.E.	Răcire/Încălzire		67 / 67
Nivel presiune sonoră*1	U.I.*3	Răcire (P-Hi/Hi/Me/Lo)		37 / 32 / 29 / 26
		Încălzire (P-Hi/Hi/Me/Lo)		37 / 32 / 29 / 26
	U.E.	Răcire/Încălzire		53 / 51
Flux de aer	U.I.*3	Răcire (P-Hi/Hi/Me/Lo)	m ³ /min	13 / 10 / 9 / 8
		Încălzire (P-Hi/Hi/Me/Lo)		13 / 10 / 9 / 8
	U.E.	Răcire/Încălzire		100 / 100
Presiune statică externă			Pa	Standard:35 Max:100
Exterior dimensions	U.I.	HeightxWidthxDepth	mm	280 x 750 x 635
	U.E.		mm	1,300 x 970 x 370
Greutate netă		U.I./U.E.	kg	29 / 99
Refrigerant charge			kg/TCO ₂ E	4.0/2.7
Refrigerant Type GWP				R32/675
Ref.piping size	Lichid/Gaz		Ț, mm	9.52(3/8") / 15.88(5/8")
Lungime țeavă refrigerant (o direcție)			m	Max.100
Diferență de nivel suportată	Unitate externă este mai sus/mai jos		m	Max.50 / Max.15

Datorită politicii de continuă îmbunătățire a produselor, ne rezervăm dreptul de a modifica specificațiile tehnice fără nicio notificare prealabilă.



TEMPERATURE CONTROL FOR TODAY & TOMORROW



Interval de funcționare - temperatură exterioară	Răcire*2	°C	-15~50
	Încălzire	°C	-20~20
Filtru de aer, cantitate			(Opțional) Kit filtru : UM- FL1EF
Telecomandă (opțional)			Cu fir:RC-EX3A, RC-E5, RCH-E3 Wireless:RCN- KIT4-E2
Clasa Energetică (Răcire/Încălzire)			A++/A
SEER			6.36
SCOP (Climat temperat)			3.88
Pdesign (răcire/încălzire(@-10°C))			10.0/10.0
Annual Electricity Consumption			550/3605
Performanța pe modul încălzire			Climat temperat

Schema tehnica

Datorită politicii de continuă îmbunătățire a produselor, ne rezervăm dreptul de a modifica specificațiile tehnice fără nicio notificare prealabilă.



TEMPERATURE CONTROL FOR TODAY & TOMORROW



Models FDUM40VH, FDUM50VH

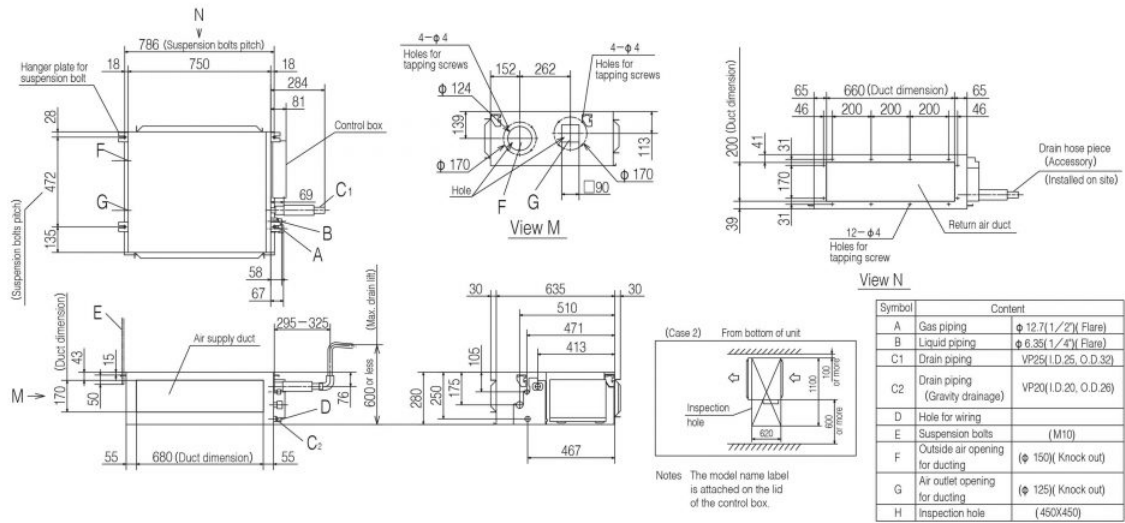

Datorită politicii de continuă îmbunătățire a produselor, ne rezervăm dreptul de a modifica specificațiile tehnice fără nicio notificare prealabilă.



TEMPERATURE CONTROL FOR TODAY & TOMORROW



FDC100VN-X-W, 125VN-X-W, 140VN-X-W, 100VS-X-W, 125VS-X-W, 140VS-X-W

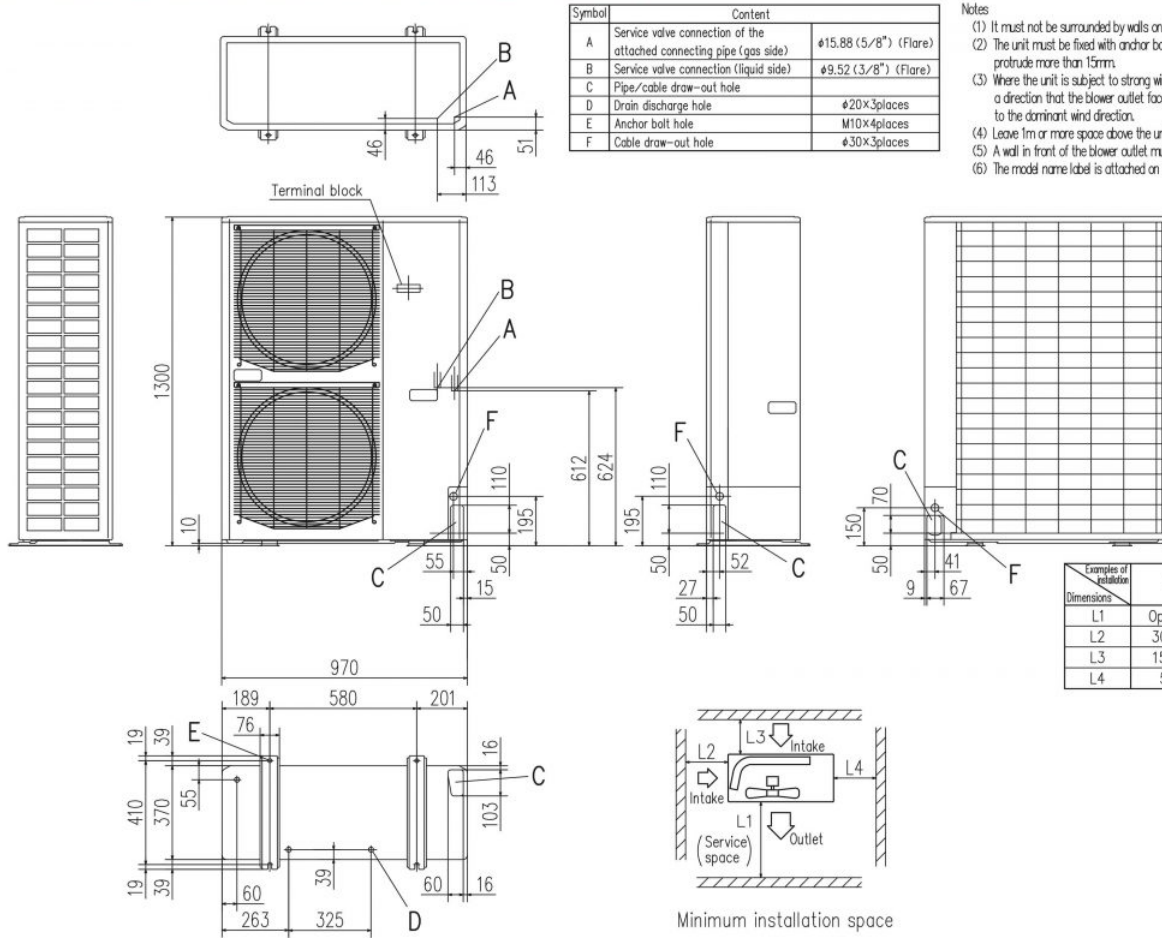

- Notes
- (1) It must not be surrounded by walls on the four sides.
 - (2) The unit must be fixed with anchor bolts. An anchor bolt must not protrude more than 15mm.
 - (3) Where the unit is subject to strong winds, lay it in such a direction that the blower outlet faces perpendicularly to the dominant wind direction.
 - (4) Leave 1m or more space above the unit.
 - (5) A wall in front of the blower outlet must not exceed the units height.
 - (6) The model name label is attached on the lower right corner of the front panel.

Datorită politicii de continuă îmbunătățire a produselor, ne rezervăm dreptul de a modifica specificațiile tehnice fără nicio notificare prealabilă.