



TEMPERATURE CONTROL  
FOR TODAY & TOMORROW



## FDUM125VNPWVH

Capacitate nominala de racire: **12.1 KW**



### Poze unitate interna si unitate externa

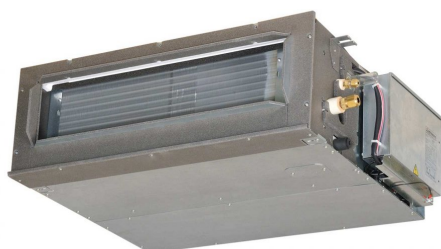

### Specificatii

Unitate internă		FDUM125VH	
Unitate externă		FDC125VNP-W	
Sursă de alimentare		Monofazic 220-240V, 50Hz / 220V, 60Hz	
Capacitate nominală de răcire (Min~Max)		kW	12.1 ( 5.0 ~ 12.1 )
Capacitate nominală de încălzire (Min~Max)		kW	12.1 ( 4.0 ~ 13.3 )
Consum de energie	Răcire/Încălzire	kW	3.85 / 3.28
EER/COP	Răcire/Încălzire		3.14 / 3.69



## TEMPERATURE CONTROL FOR TODAY & TOMORROW



Curent de intrare			A	5
Amperaj maxim			A	20
Nivel putere sonoră*1	U.I. *3	Răcire/Încălzire	dB(A)	67 / 67
	U.E.	Răcire/Încălzire		73 / 72
Nivel presiune sonoră*1	U.I. *3	Răcire (Hi/Me/Lo/Ulo)		45 / 40 / 34 / 29
		Încălzire (Hi/Me/Lo/Ulo)		45 / 40 / 34 / 29
	U.E.	Răcire/Încălzire		57 / 57
Flux de aer	U.I. *3	Răcire (Hi/Me/Lo/Ulo)	m <sup>3</sup> /min	39 / 32 / 26 / 20
		Încălzire (Hi/Me/Lo/Ulo)		39 / 32 / 26 / 20
	U.E.	Răcire/Încălzire		75 / 79
Presiune statică externă disponibilă			Pa	Standard:60 Max:100
Dimensiuni exterioare	U.I.	Înălțime / Lățime / Adâncime	mm	280 x 1,370 x 740
	U.E.			845 x 970 x 370
Greutate netă	U.I. / U.E.		kg	54 / 73
Refrigerant		Tip/GWP		R32/675
Dimensiuni țevă refrigerant		Lichid/Gaz	mm/ø	9.52(3/8") / 15.88(5/8")
Lungime țevă refrigerant (o direcție)			m	Max.30
Diferență de nivel suportată		Unitate externă este mai sus/mai jos	m	Max.20 / Max.20

**Datorită politicii de continuă îmbunătățire a produselor, ne rezervăm dreptul de a modifica specificațiile tehnice fără nicio notificare prealabilă.**



## TEMPERATURE CONTROL FOR TODAY & TOMORROW



Interval de funcționare - temperatură exterioară	Răcire*2	°C	-15~46
	Încălzire		-15~20
Filtru de aer (cantitate)			(Opțional) Kit filtru : UM-FL3EF
Telecomandă (opțional)			Cu fir:RC-EX3A, RC-E5, RCH-E3 Wireless:RCN-KIT4-E2
Clasa Energetică (Răcire/Încălzire)			A++/A+
SEER			5.50
SCOP (Climat temperat)			4.01
Pdesign (răcire/încălzire(@-10°C))		kW	10.0/6.4
Consumul anual de electricitate (răcire/încălzire)		kWh/a	573/2169
Performanța pe modul încălzire			Climat temperat

## Schema tehnica

---

**Datorită politicii de continuă îmbunătățire a produselor, ne rezervăm dreptul de a modifica specificațiile tehnice fără nicio notificare prealabilă.**



# TEMPERATURE CONTROL FOR TODAY & TOMORROW



Models FDUM100VH,125VH,140VH

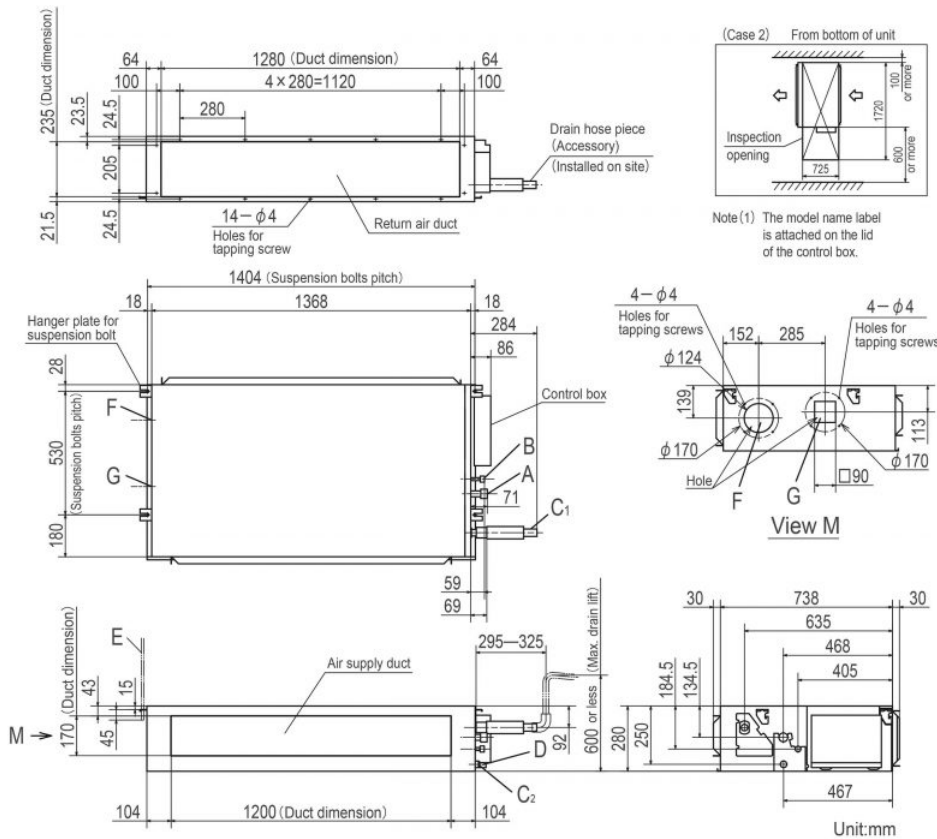

Symbol	Content
A	Gas piping φ 15.88 (5/8") (Flare)
B	Liquid piping φ 9.52 (3/8") (Flare)
C <sub>1</sub>	Drain piping VP25 (O.D.32)
C <sub>2</sub>	Drain piping (Gravity drainage) VP20
D	Hole for wiring
E	Suspension bolts (M10)
F	Outside air opening for ducting (φ 150) (Knock out)
G	Air outlet opening for ducting (φ 125) (Knock out)
H	Inspection opening (450×450)

### Space for installation and service

Select either of two cases to keep space for installation and services.  
(Case 1) From side of unit

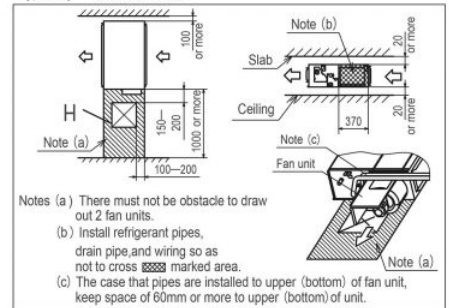

**Datorită politicii de continuă îmbunătățire a produselor, ne rezervăm dreptul de a modifica specificațiile tehnice fără nicio notificare prealabilă.**



# TEMPERATURE CONTROL FOR TODAY & TOMORROW



FDC90VNP-W, 100VNP-W  
FDC90VNP1

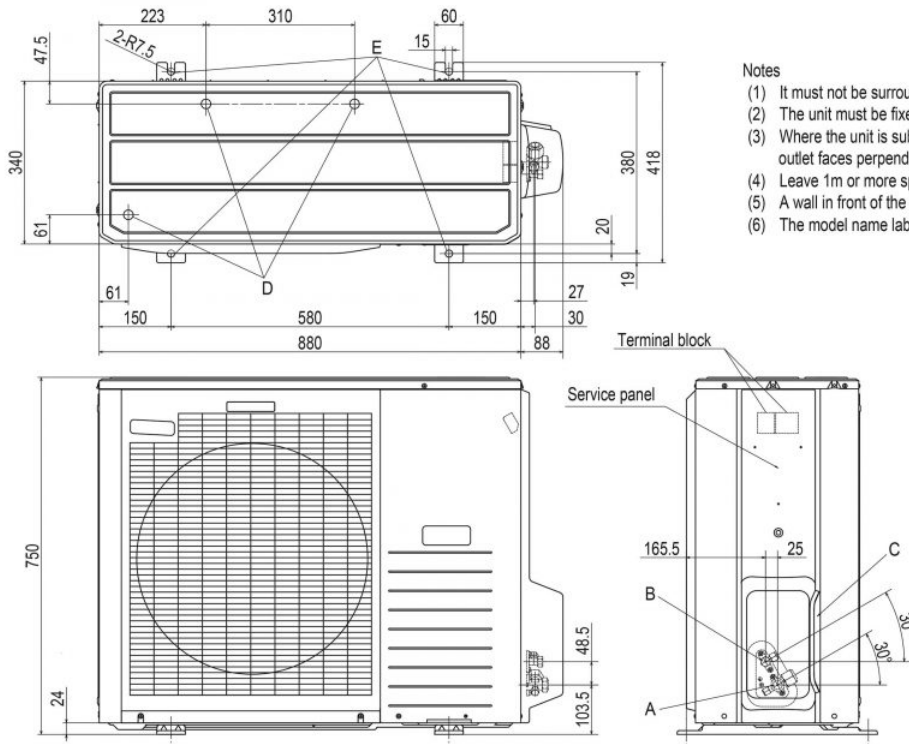

**Notes**

- (1) It must not be surrounded by walls on four sides.
- (2) The unit must be fixed with anchor bolts. An anchor bolt must not protrude more than 15mm.
- (3) Where the unit is subjected to strong winds, lay it in such a direction that the blower outlet faces perpendicularly to the dominant wind direction.
- (4) Leave 1m or more space above the unit.
- (5) A wall in front of the blower outlet must not exceed the unit's height.
- (6) The model name label is attached on the lower right corner of the front panel.

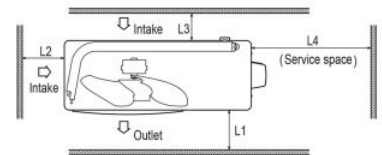

Minimum installation space

Examples of installation Dimensions	I			II			III		
	L1	L2	L3	L1	L2	L3	L1	L2	L3
L1	Open	Open	Open	Open	Open	Open	Open	Open	Open
L2	300	250	Open	300	250	Open	300	250	Open
L3	100	150	100	100	150	100	100	150	100
L4	250	250	250	250	250	250	250	250	250

Symbol	Content	
A	Service valve connection (gas side)	φ 15.88(5/8") (Flare)
B	Service valve connection (liquid side)	φ 6.35(1/4") (Flare)
C	Pipe / cable draw-out hole	
D	Drain discharge hole	φ 20 x 3 places
E	Anchor bolt hole	M10 x 4 places

**Datorită politicii de continuă îmbunătățire a produselor, ne rezervăm dreptul de a modifica specificațiile tehnice fără nicio notificare prealabilă.**