



TEMPERATURE CONTROL
FOR **TODAY & TOMORROW**

MITSUBISHI
HEAVY INDUSTRIES

FDUM125VNXVH

Capacitate nominala de racire: **12.5 KW**



Poze unitate interna si unitate externa



Specificatii

Unitate internă		FDUM125VH	
Unitate externă		FDC125VNX	
Sursă de alimentare		Monofazic 220-240V, 50Hz / 220V, 60Hz	
Capacitate nominală de răcire (Min~Max)		kW	12.5 (5.0 ~ 14.0)
Capacitate nominală de încălzire (Min~Max)		kW	14.0 (4.0-17.0)
Consum de energie	Răcire/Încălzire	kW	3.49 / 3.77
EER/COP	Răcire/Încălzire		3.58 / 3.71



TEMPERATURE CONTROL FOR TODAY & TOMORROW



Curent de intrare			A	5
Amperaj maxim			A	26
Nivel putere sonoră*1	U.I. *3	Răcire/Încălzire	dB(A)	67 / 67
	U.E.	Răcire/Încălzire		70 / 70
Nivel presiune sonoră*1	U.I. *3	Răcire (Hi/Me/Lo/Ulo)		45 / 40 / 34 / 29
		Încălzire (Hi/Me/Lo/Ulo)		45 / 40 / 34 / 29
	U.E.	Răcire/Încălzire		48 / 50
Flux de aer	U.I. *3	Răcire (Hi/Me/Lo/Ulo)	m ³ /min	39 / 32 / 26 / 20
		Încălzire (Hi/Me/Lo/Ulo)		39 / 32 / 26 / 20
	U.E.	Răcire/Încălzire		100 / 100
Presiune statică externă disponibilă			Pa	Standard:60 Max:100
Dimensiuni exterioare	U.I.	Înălțime / Lățime / Adâncime	mm	280 x 1,370 x 740
	U.E.			1,300 x 970 x 370
Greutate netă	U.I. / U.E.		kg	54 / 105
Refrigerant		Tip/GWP		R410A/2088
Dimensiuni țevă refrigerant		Lichid/Gaz	mm/ø	9.52(3/8") / 15.88(5/8")
Lungime țevă refrigerant (o direcție)			m	Max.100
Diferență de nivel suportată		Unitate externă este mai sus/mai jos	m	Max.30 / Max.15

Datorită politicii de continuă îmbunătățire a produselor, ne rezervăm dreptul de a modifica specificațiile tehnice fără nicio notificare prealabilă.



TEMPERATURE CONTROL FOR TODAY & TOMORROW



Interval de funcționare - temperatură exterioară	Răcire*2	°C	-15~43
	Încălzire		-20~20
Filtru de aer (cantitate)			(Opțional) Kit filtru : UM-FL3EF
Telecomandă (opțional)			Cu fir:RC-EX3A, RC-E5, RCH-E3 Wireless:RCN-KIT4-E2
SEER			5.34
SCOP (Climat temperat)			3.87

Schema tehnica

Datorită politicii de continuă îmbunătățire a produselor, ne rezervăm dreptul de a modifica specificațiile tehnice fără nicio notificare prealabilă.



TEMPERATURE CONTROL FOR TODAY & TOMORROW



Models FDUM100VH,125VH,140VH

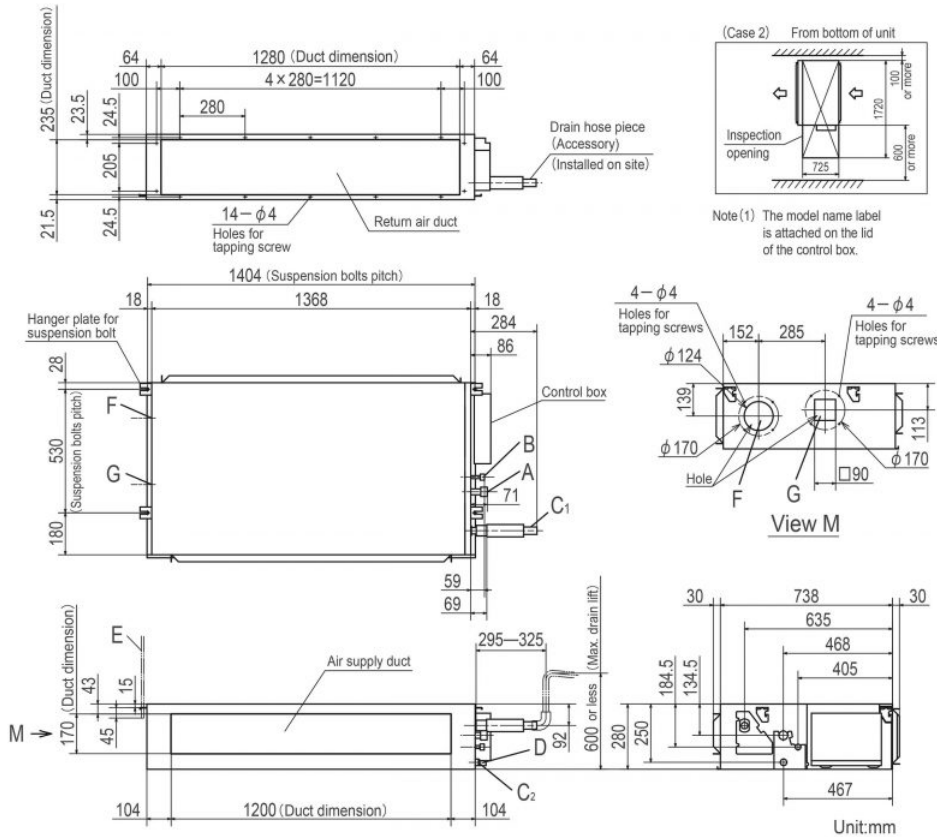

Symbol	Content
A	Gas piping φ 15.88 (5/8") (Flare)
B	Liquid piping φ 9.52 (3/8") (Flare)
C ₁	Drain piping VP25 (O.D.32)
C ₂	Drain piping (Gravity drainage) VP20
D	Hole for wiring
E	Suspension bolts (M10)
F	Outside air opening for ducting (φ 150) (Knock out)
G	Air outlet opening for ducting (φ 125) (Knock out)
H	Inspection opening (450×450)

Space for installation and service

Select either of two cases to keep space for installation and services.
(Case 1) From side of unit

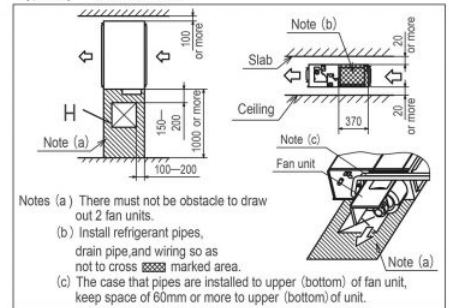

Datorită politicii de continuă îmbunătățire a produselor, ne rezervăm dreptul de a modifica specificațiile tehnice fără nicio notificare prealabilă.



TEMPERATURE CONTROL FOR TODAY & TOMORROW



FDC100VNX, 100VSX, 125VNX, 125VSX,
140VNX, 140VSX

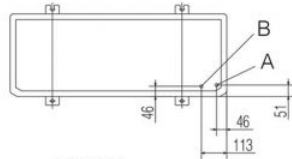

Symbol	Content
A	Service valve connection of the attached connecting pipe (gas side) $\phi 15.88$ (5/8") (Flare)
B	Service valve connection (liquid side) $\phi 9.52$ (3/8") (Flare)
C	Pipe / cable draw-out hole
D	Drain discharge hole $\phi 20 \times 3$ places
E	Anchor bolt hole M10 \times 4places
F	Cable draw-out hole $\phi 30$ (front) $\phi 45$ (side) $\phi 50$ (back)

Notes

- (1) It must not be surrounded by walls on the four sides.
- (2) The unit must be fixed with anchor bolts. An anchor bolt must not protrude more than 15mm.
- (3) Where the unit is subject to strong winds, lay it in such a direction that the blower outlet faces perpendicularly to the dominant wind direction.
- (4) Leave 1m or more space above the unit.
- (5) A wall in front of the blower outlet must not exceed the unit's height.
- (6) The model name label is attached on the lower right corner of the front panel.
- (7) Connect the Service valve with local pipe by using the pipe of the attachment. (Gas side only)

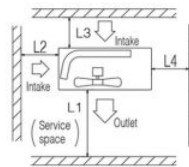
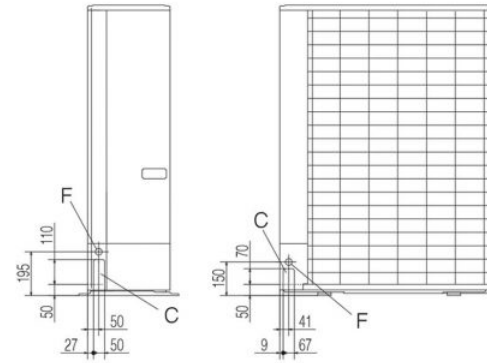
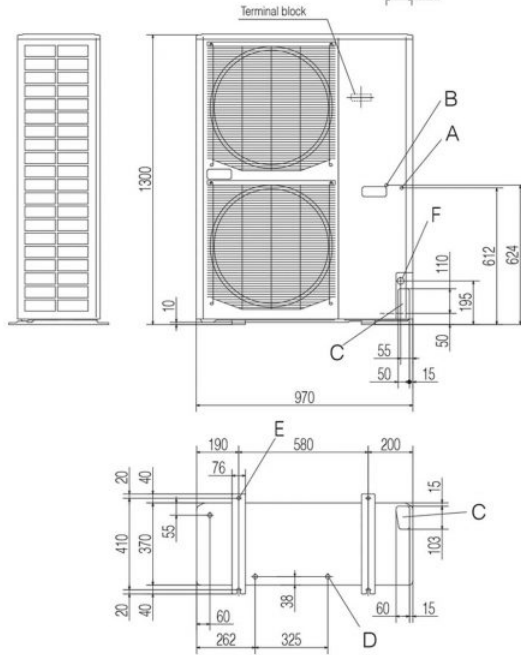

Minimum installation space

Examples of Dimensions	Examples of separator		
	I	II	III
L1	Open	Open	500
L2	300	5	Open
L3	150	300	150
L4	5	5	5

Datorită politicii de continuă îmbunătățire a produselor, ne rezervăm dreptul de a modifica specificațiile tehnice fără nicio notificare prealabilă.