



TEMPERATURE CONTROL  
FOR TODAY & TOMORROW



## FDUM140VNXWPVH

Capacitate nominala de racire: **14.0 KW**



## Poze unitate interna si unitate externa



## Specificatii

Unitate internă		FDUM71VH x 2	
Unitate externă		FDC140VNX-W	
Sursă de alimentare		Monofazic 220-240V, 50Hz / 220V, 60Hz	
Capacitate nominală de răcire (Min-Max)		kW	14.0 ( 3.5 ~ 16.0 )
Capacitate nominală de încălzire (Min-Max)		kW	16.0 ( 2.7 ~ 18.0 )
Power Consumption	Răcire/Încălzire	kW	3.97 / 3.91
EER/COP	Răcire/Încălzire	kW	3.53 / 4.10



## TEMPERATURE CONTROL FOR TODAY & TOMORROW



Curent de intrare			A	5
Max. current			A	30
Nivel putere sonoră*1	U.I.*3	Răcire/Încălzire	dB(A)	65 / 65
	U.E.	Răcire/Încălzire		69 / 71
Nivel presiune sonoră*1	U.I.*3	Răcire (P-Hi/Hi/Me/Lo)		38 / 33 / 29 / 25
		Încălzire (P-Hi/Hi/Me/Lo)		38 / 33 / 29 / 25
	U.E.	Răcire/Încălzire		54 / 54
Flux de aer	U.I.*3	Răcire (P-Hi/Hi/Me/Lo)	m <sup>3</sup> /min	24 / 19 / 15 / 10
		Încălzire (P-Hi/Hi/Me/Lo)		24 / 19 / 15 / 10
	U.E.	Răcire/Încălzire		100 / 100
Presiune statică externă			Pa	Standard:35 Max:100
Exterior dimensions	U.I.	HeightxWidthxDepth	mm	280 x 950 x 635
	U.E.		mm	1,300 x 970 x 370
Greutate netă		U.I./U.E.	kg	34 / 97
Refrigerant Type GWP				R32/675
Ref.piping size	Lichid/Gaz		Ț, mm	9.52(3/8") / 15.88(5/8")
Lungime țeavă refrigerant (o direcție)			m	Max.100
Diferență de nivel suportată		Unitate externă este mai sus/mai jos	m	Max.50 / Max.15
Interval de funcționare - temperatură exterioară		Răcire*2	°C	-15~50

**Datorită politicii de continuă îmbunătățire a produselor, ne rezervăm dreptul de a modifica specificațiile tehnice fără nicio notificare prealabilă.**



# TEMPERATURE CONTROL FOR TODAY & TOMORROW



Încălzire	°C	-20~20	
Filtru de aer, cantitate			(Opțional) Kit filtru : UM-FL2EF
Telecomandă (opțional)			Cu fir:RC-EX3A, RC-E5, RCH-E3 Wireless:RCN-KIT4-E2

## Schema tehnica

### Models FDUM60VH,71VH

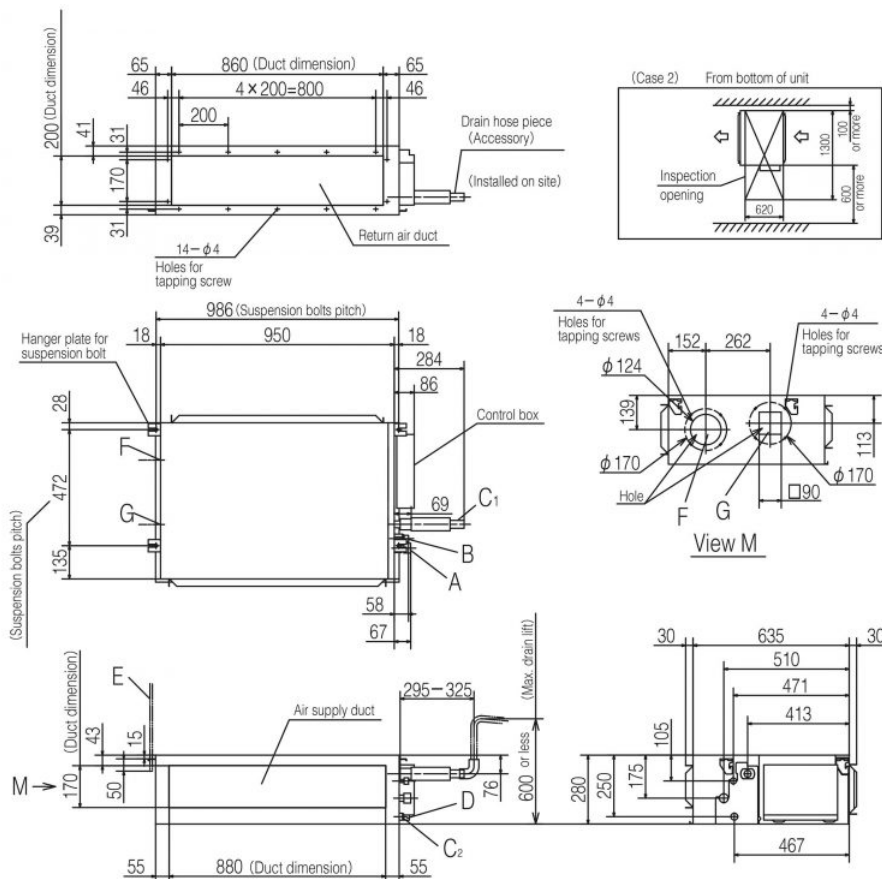

Symbol	Content		
	Model	60	71
A	Gas piping	φ 12.7 (1/2") (Flare)	φ 15.88 (5/8") (Flare)
B	Liquid piping	φ 6.35 (1/4") (Flare)	φ 9.52 (3/8") (Flare)
C1	Drain piping	VP25 ( O.D.32)	
C2	Drain piping (Gravity drainage)	VP20	
D	Hole for wiring		
E	Suspension bolts	(M10)	
F	Outside air opening for ducting	(φ 150) (Knock out)	
G	Air outlet opening for ducting	(φ 125) (Knock out)	
H	Inspection opening	(450×450)	

Note (1) The model name label is attached on the lid of the control box.

#### Space for installation and service

Select either of two cases to keep space for installation and services.

(Case 1) From side of unit

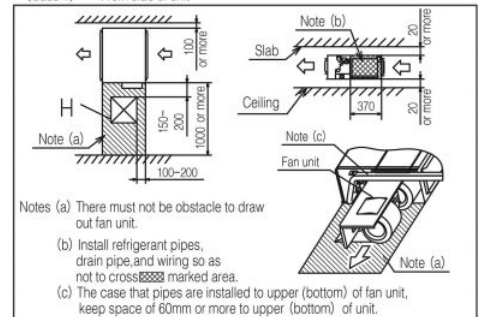

Notes (a) There must not be obstacle to draw out fan unit.

(b) Install refrigerant pipes, drain pipe, and wiring so as not to cross ~~XXXX~~ marked area.

(c) The case that pipes are installed to upper (bottom) of fan unit, keep space of 60mm or more to upper (bottom) of unit.

**Datorită politicii de continuă îmbunătățire a produselor, ne rezervăm dreptul de a modifica specificațiile tehnice fără nicio notificare prealabilă.**



# TEMPERATURE CONTROL FOR TODAY & TOMORROW



FDC100VN-X-W, 125VN-X-W, 140VN-X-W, 100VS-X-W, 125VS-X-W, 140VS-X-W

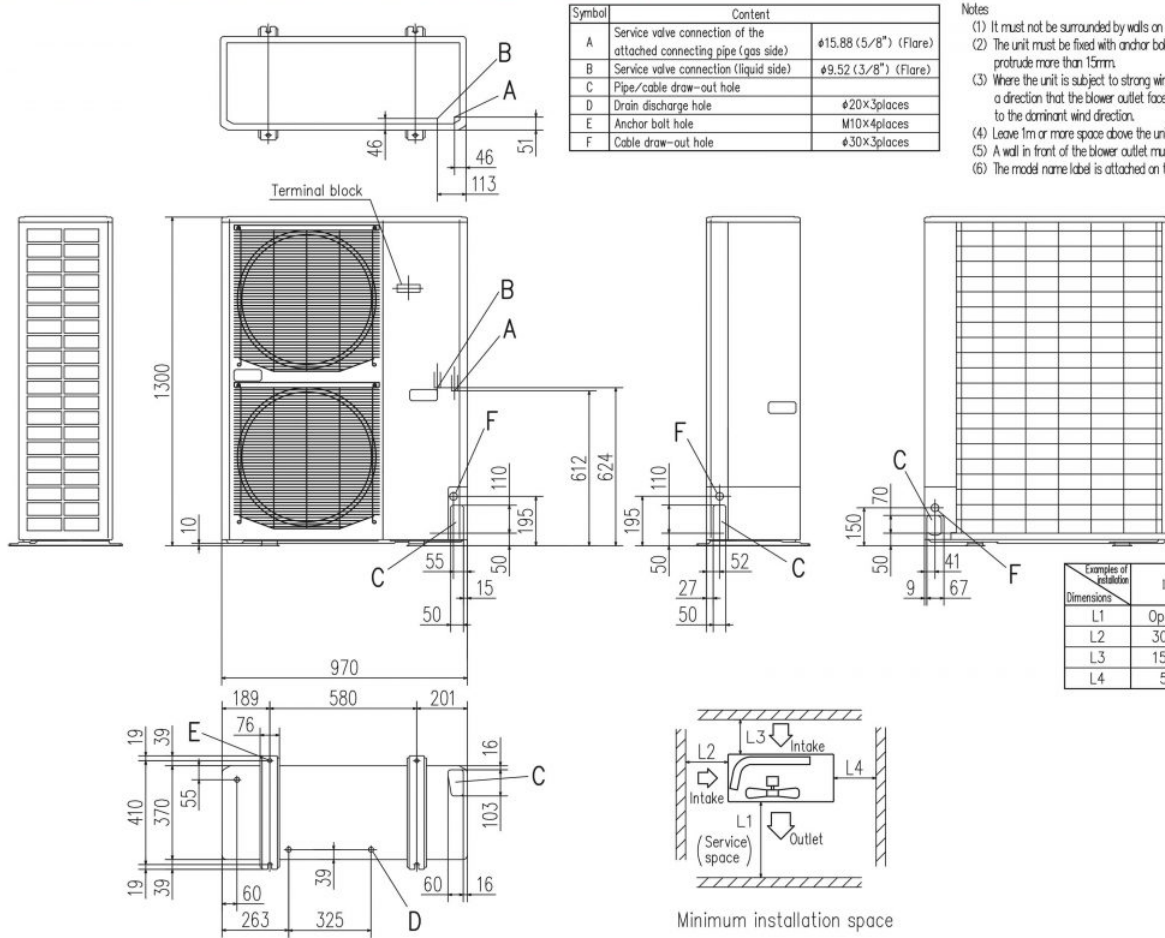

- Notes
- (1) It must not be surrounded by walls on the four sides.
  - (2) The unit must be fixed with anchor bolts. An anchor bolt must not protrude more than 15mm.
  - (3) Where the unit is subject to strong winds, lay it in such a direction that the blower outlet faces perpendicularly to the dominant wind direction.
  - (4) Leave 1m or more space above the unit.
  - (5) A wall in front of the blower outlet must not exceed the units height.
  - (6) The model name label is attached on the lower right corner of the front panel.

Minimum installation space

**Datorită politicii de continuă îmbunătățire a produselor, ne rezervăm dreptul de a modifica specificațiile tehnice fără nicio notificare prealabilă.**