



TEMPERATURE CONTROL
FOR **TODAY & TOMORROW**

mitsubishi
HEAVY INDUSTRIES

FDUM200VSATVH

Capacitate nominala de racire: **19.0 KW**



Poze unitate interna si unitate externa



Specificatii

Unitate internă			FDUM71VH x 3
Unitate externă			FDC200VSA
Sursă de alimentare			Trifazic 380-415V, 50Hz / 380V, 60Hz
Capacitate nominală de răcire (Min-Max)		kW	19.0 (5.2 ~ 22.4)
Capacitate nominală de încălzire (Min-Max)		kW	22.4 (3.3 ~ 25.0)
Power Consumption	Răcire/Încălzire	kW	6.46 / 6.15
EER/COP	Răcire/Încălzire	kW	2.94 / 3.64



TEMPERATURE CONTROL FOR TODAY & TOMORROW



Curent de intrare			A	5
Max. current			A	22
Nivel putere sonoră*1	U.I.*3	Răcire/Încălzire	dB(A)	65 / 65
	U.E.	Răcire/Încălzire		72 / 74
Nivel presiune sonoră*1	U.I.*3	Răcire (P-Hi/Hi/Me/Lo)		38 / 33 / 29 / 25
		Încălzire (P-Hi/Hi/Me/Lo)		38 / 33 / 29 / 25
	U.E.	Răcire/Încălzire		58 / 59
Flux de aer	U.I.*3	Răcire (P-Hi/Hi/Me/Lo)	m ³ /min	24 / 19 / 15 / 10
		Încălzire (P-Hi/Hi/Me/Lo)		24 / 19 / 15 / 10
	U.E.	Răcire/Încălzire		135 / 135
Presiune statică externă			Pa	Standard:35 Max:100
Exterior dimensions	U.I.	HeightxWidthxDepth	mm	280 x 950 x 635
	U.E.		mm	1,300 x 970 x 370
Greutate netă		U.I./U.E.	kg	34 / 115
Refrigerant Type GWP				R410A/2088
Ref.piping size	Lichid/Gaz		Ț, mm	9.52(3/8") / 22.22(7/8")
Lungime țeavă refrigerant (o direcție)			m	Max.70
Diferență de nivel suportată		Unitate externă este mai sus/mai jos	m	Max.30 / Max.15
Interval de funcționare - temperatură exterioară		Răcire*2	°C	-15~50

Datorită politicii de continuă îmbunătățire a produselor, ne rezervăm dreptul de a modifica specificațiile tehnice fără nicio notificare prealabilă.



TEMPERATURE CONTROL FOR TODAY & TOMORROW



Încălzire	°C	-15~20	
Filtru de aer, cantitate			(Opțional) Kit filtru : UM-FL2EF
Telecomandă (opțional)			Cu fir:RC-EX3A, RC-E5, RCH-E3 Wireless:RCN-KIT4-E2

Schema tehnica

Models FDUM60VH,71VH

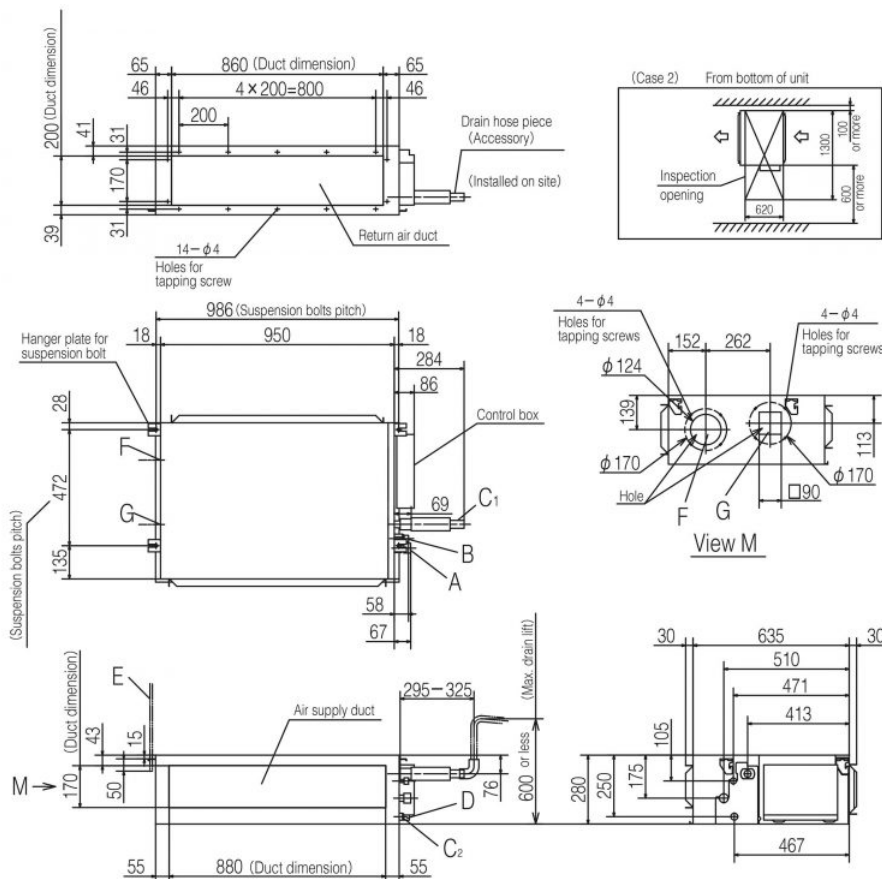

Symbol	Content		
	Model	60	71
A	Gas piping	φ 12.7 (1/2") (Flare)	φ 15.88 (5/8") (Flare)
B	Liquid piping	φ 6.35 (1/4") (Flare)	φ 9.52 (3/8") (Flare)
C1	Drain piping	VP25 (O.D.32)	
C2	Drain piping (Gravity drainage)	VP20	
D	Hole for wiring		
E	Suspension bolts	(M10)	
F	Outside air opening for ducting	(φ 150) (Knock out)	
G	Air outlet opening for ducting	(φ 125) (Knock out)	
H	Inspection opening	(450×450)	

Note (1) The model name label is attached on the lid of the control box.

Space for installation and service

Select either of two cases to keep space for installation and services.

(Case 1) From side of unit

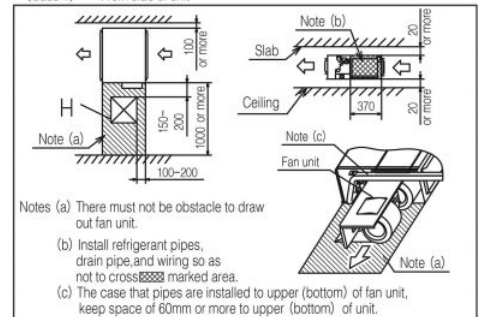

Datorită politicii de continuă îmbunătățire a produselor, ne rezervăm dreptul de a modifica specificațiile tehnice fără nicio notificare prealabilă.



TEMPERATURE CONTROL FOR TODAY & TOMORROW



FDC200VSA

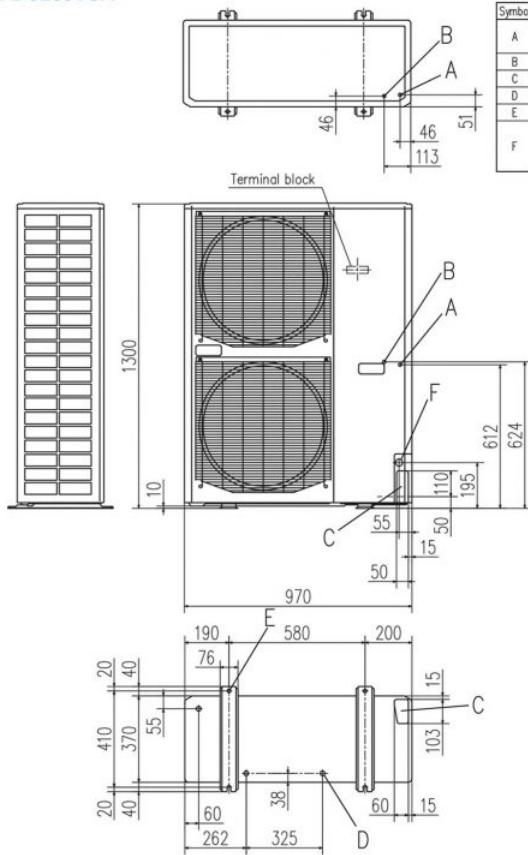

Symbol	Content	
A	Service valve connection of the attached connecting pipe (gas side)	φ19.05 (3/4") (Flare)
B	Service valve connection (liquid side)	φ9.52 (3/8") (Flare)
C	Pipe/cable draw-out hole	
D	Drain discharge hole	φ20×3places
E	Anchor bolt hole	M10×4places
F	Cable draw-out hole	φ30 (front) φ30 (side) φ30 (back)

Notes

- (1) It must not be surrounded by walls on the four sides.
- (2) The unit must be fixed with anchor bolts. An anchor bolt must not protrude more than 15mm.
- (3) Where the unit is subject to strong winds, lay it in such a direction that the blower outlet faces perpendicularly to the dominant wind direction.
- (4) Leave 1m or more space above the unit.
- (5) A wall in front of the blower outlet must not exceed the units height.
- (6) The model name label is attached on the lower right corner of the front panel.
- (7) Connect the Service valve with local pipe by using the pipe of the attachment. (Gas side only)
- (8) Regarding attaching the pipe of accessories, refer to an attached installation manual.

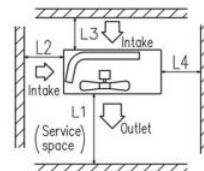
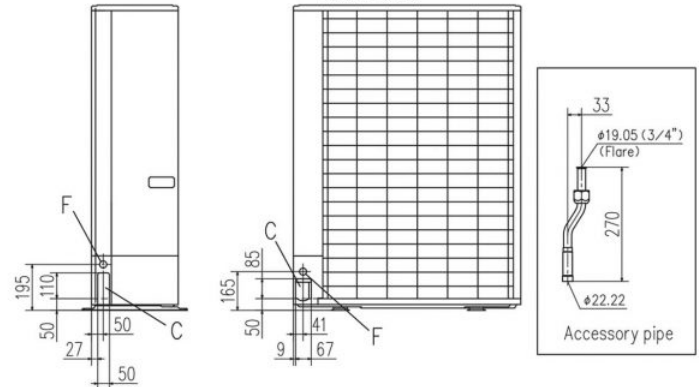

Minimum installation space

Dimensions	Examples of installation		
	I	II	III
L1	Open	Open	500
L2	300	5	Open
L3	150	300	150
L4	5	5	5

Datorită politicii de continuă îmbunătățire a produselor, ne rezervăm dreptul de a modifica specificațiile tehnice fără nicio notificare prealabilă.