



TEMPERATURE CONTROL
FOR TODAY & TOMORROW

MITSUBISHI
HEAVY INDUSTRIES

FDUM200VSAWTVH

Capacitate nominala de racire: **20.0 KW**



Poze unitate interna si unitate externa



Specificatii

Unitate internă			FDUM71VH x 3
Unitate externă			FDC200VSA-W
Sursă de alimentare			Trifazic 380-415V, 50Hz / 380V, 60Hz
Capacitate nominală de răcire (Min-Max)		kW	20.0 (6.8 ~ 22.4)
Capacitate nominală de încălzire (Min-Max)		kW	22.4 (6.7 ~ 25.0)
Power Consumption	Răcire/Încălzire	kW	6.58 / 5.59
EER/COP	Răcire/Încălzire	kW	3.04 / 4.01



TEMPERATURE CONTROL FOR TODAY & TOMORROW



Curent de intrare			A	5
Max. current			A	19
Nivel putere sonoră*1	U.I.*3	Răcire/Încălzire	dB(A)	65 / 65
	U.E.	Răcire/Încălzire		72 / 74
Nivel presiune sonoră*1	U.I.*3	Răcire (P-Hi/Hi/Me/Lo)		38 / 33 / 29 / 25
		Încălzire (P-Hi/Hi/Me/Lo)		38 / 33 / 29 / 25
	U.E.	Răcire/Încălzire		58 / 59
Flux de aer	U.I.*3	Răcire (P-Hi/Hi/Me/Lo)	m ³ /min	24 / 19 / 15 / 10
		Încălzire (P-Hi/Hi/Me/Lo)		24 / 19 / 15 / 10
	U.E.	Răcire/Încălzire		148 / 134
Presiune statică externă			Pa	Standard:35 Max:100
Exterior dimensions	U.I.	HeightxWidthxDepth	mm	280 x 950 x 635
	U.E.		mm	1,505 x 970 x 370
Greutate netă		U.I./U.E.	kg	34 / 144
Refrigerant Type GWP				R32/675
Ref.piping size	Lichid/Gaz		Ț, mm	9.52(3/8") / 22.22(7/8")
Lungime țeavă refrigerant (o direcție)			m	Max.70
Diferență de nivel suportată		Unitate externă este mai sus/mai jos	m	Max.50 / Max.15
Interval de funcționare - temperatură exterioară		Răcire*2	°C	-15~50

Datorită politicii de continuă îmbunătățire a produselor, ne rezervăm dreptul de a modifica specificațiile tehnice fără nicio notificare prealabilă.



TEMPERATURE CONTROL FOR TODAY & TOMORROW



Încălzire	°C	-20~20	
Filtru de aer, cantitate			Discutați cu un specialist ATX
Telecomandă (opțional)			Cu fir: RC-EX3A, RC-E5, RCH-E3 Wireless: RCN-KIT4-E2

Schema tehnica

Models FDUM60VH,71VH

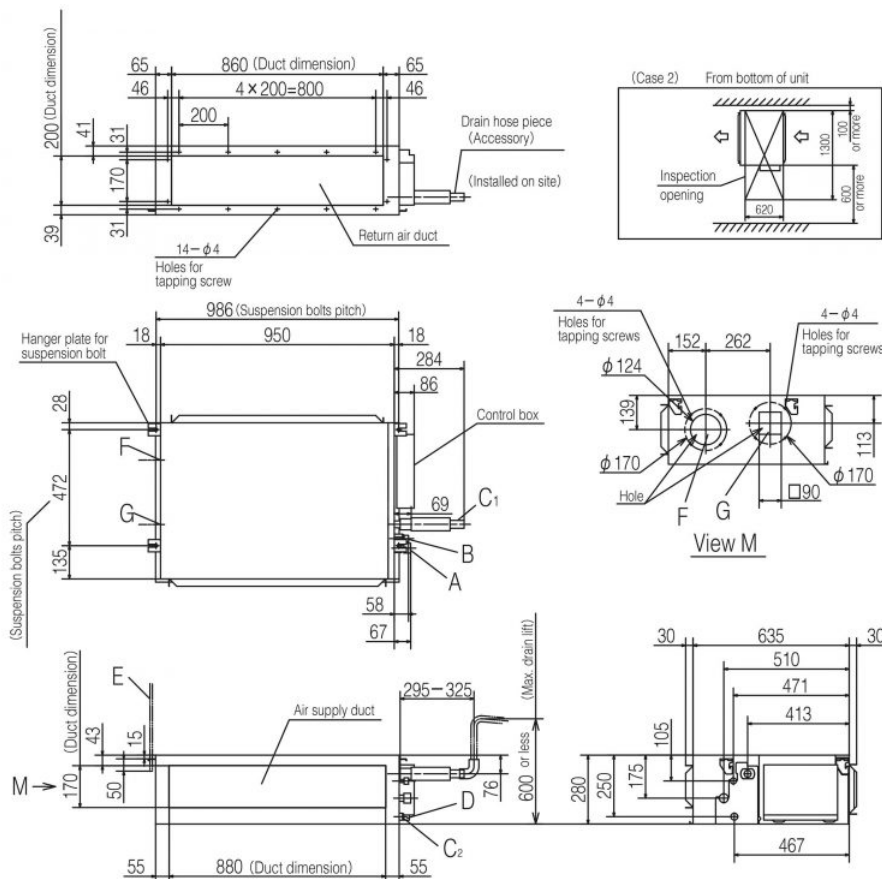

Symbol	Content	
	Model 60	71
A	Gas piping	$\phi 12.7 (1/2")$ (Flare) $\phi 15.88 (5/8")$ (Flare)
B	Liquid piping	$\phi 6.35 (1/4")$ (Flare) $\phi 9.52 (3/8")$ (Flare)
C1	Drain piping	VP25 (O.D.32)
C2	Drain piping (Gravity drainage)	VP20
D	Hole for wiring	
E	Suspension bolts	(M10)
F	Outside air opening for ducting	($\phi 150$) (Knock out)
G	Air outlet opening for ducting	($\phi 125$) (Knock out)
H	Inspection opening	(450×450)

Note (1) The model name label is attached on the lid of the control box.

Space for installation and service

Select either of two cases to keep space for installation and services.

(Case 1) From side of unit

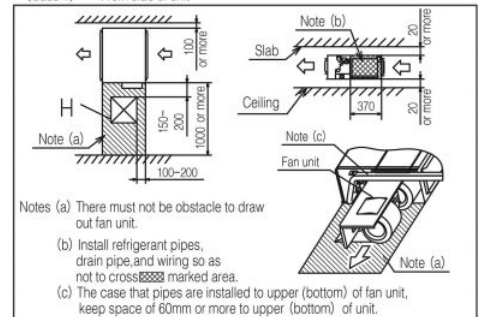

Notes (a) There must not be obstacle to draw out fan unit.

(b) Install refrigerant pipes, drain pipe, and wiring so as not to cross ~~XXXX~~ marked area.

(c) The case that pipes are installed to upper (bottom) of fan unit, keep space of 60mm or more to upper (bottom) of unit.

Datorită politicii de continuă îmbunătățire a produselor, ne rezervăm dreptul de a modifica specificațiile tehnice fără nicio notificare prealabilă.



TEMPERATURE CONTROL FOR TODAY & TOMORROW



FDC200VSA-W, 250VSA-W, FDC280VSA-W
FDC250VSA

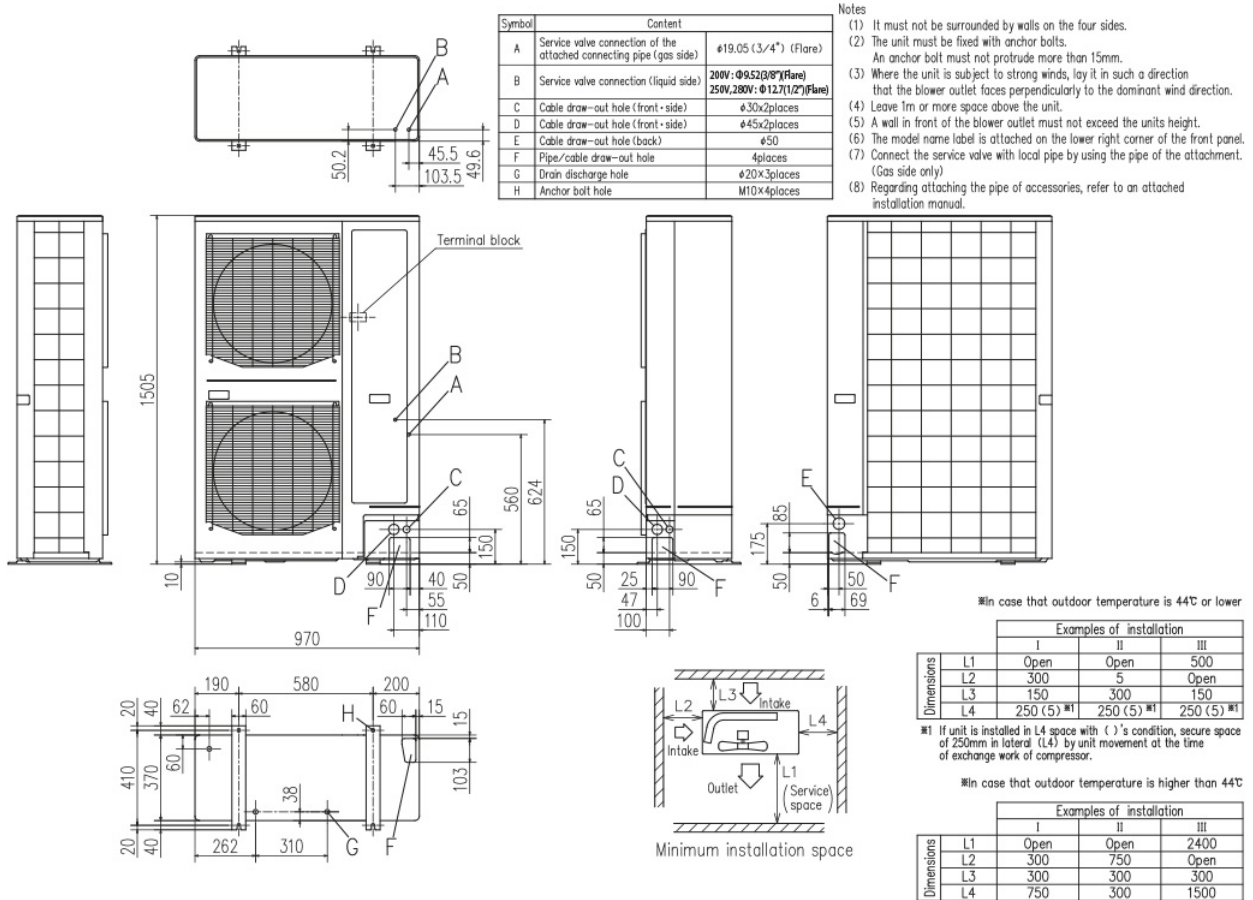

Datorită politicii de continuă îmbunătățire a produselor, ne rezervăm dreptul de a modifica specificațiile tehnice fără nicio notificare prealabilă.