



TEMPERATURE CONTROL
FOR TODAY & TOMORROW

mitsubishi
HEAVY INDUSTRIES

FDUM22KXE6F

Capacitate nominala de racire: **2.2 KW**



Specificatii

Capacitate nominală de răcire		kW	2.2
Capacitate nominala de incalzire		kW	2.5
Sursă de alimentare			Monofazic 220-240V, 50Hz
Consumul de energie	Racire	kW	0.10-0.10
	Incalzire	kW	0.10-0.10
Nivel putere sonoră		dB(A)	60
Nivel de presiune sonoră racire		db(A)	P-Hi: 37 Hi:32 Me:29 Lo:26
Dimensiuni exterioare unitate	I x L x A	mm	280 x 750 x 635
Greutate netă		kg	29
Flux de aer		m ³ /min	P-Hi: 13 Hi:10 Me:9 Lo:8
Presiunea statica externa maxima		Pa	100
Aport de aer proaspat			Este posibil



TEMPERATURE CONTROL FOR TODAY & TOMORROW



Filtru de aer		Kit filtru::UM-FL1EF/UM-FL2EF/UM-FL3EF (opționalal)
Telecomanda (opționalal)		Cu fir: RC-EX3A, RC-E5, RCH-E3 Fara fir: RCN-KIT4-E2
Dimensiuni țevă refrigerant	mm(in)	Refrigerant lichid: $\varnothing 6.35(1/4")$ Refrigerant gazos: $\varnothing 9.52(3/8")$

Schema tehnica

FDUM22KXE6F, 28KXE6F, 36KXE6F, 45KXE6F, 56KXE6F

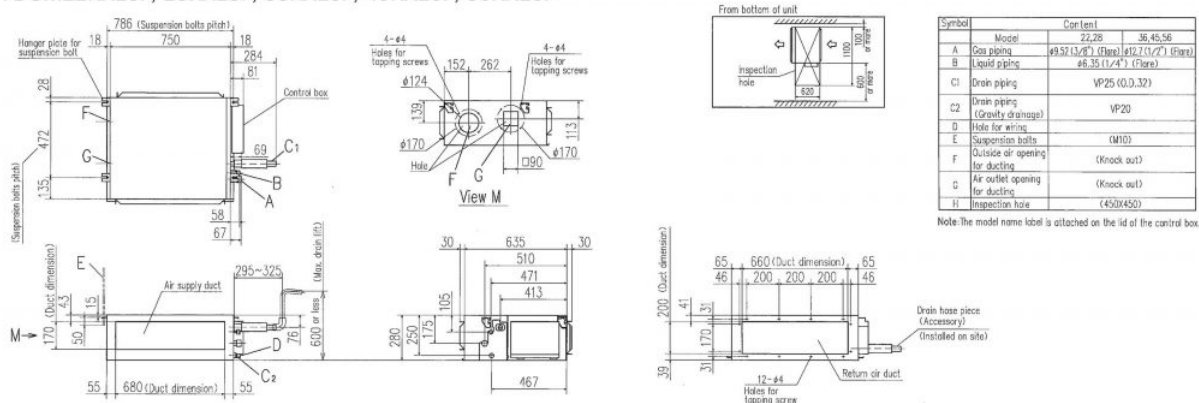

Datorită politicii de continuă îmbunătățire a produselor, ne rezervăm dreptul de a modifica specificațiile tehnice fără nicio notificare prealabilă.