



TEMPERATURE CONTROL
FOR TODAY & TOMORROW

mitsubishi
HEAVY INDUSTRIES

SRK125VSXWPZSX

Capacitate nominala de racire: **12.5 KW**



Poze unitate interna si unitate externa



Specificatii

Unitate internă		SRK60ZSX-W x 2	
Unitate externă		FDC125VSX-W	
Sursă de alimentare		Trifazic 380-415V, 50Hz / 380V, 60Hz	
Capacitate nominală de răcire (Min-Max)		kW	12.5 (3.5 ~ 14.0)
Capacitate nominală de încălzire (Min-Max)		kW	14.0 (2.7 ~ 18.0)
Power Consumption	Răcire/Încălzire	kW	3.43 / 3.42
EER/COP	Răcire/Încălzire	kW	3.64 / 4.09



TEMPERATURE CONTROL FOR TODAY & TOMORROW



Curent de intrare			A	5
Max. current			A	14
Nivel putere sonoră*1	U.I.*3	Răcire/Încălzire	dB(A)	62 / 63
	U.E.	Răcire/Încălzire		68 / 70
Nivel presiune sonoră*1	U.I.*3	Răcire (P-Hi/Hi/Me/Lo)		46 / 41 / 33 / 22
		Încălzire (P-Hi/Hi/Me/Lo)		46 / 42 / 34 / 23
	U.E.	Răcire/Încălzire		53 / 54
Flux de aer	U.I.*3	Răcire (P-Hi/Hi/Me/Lo)	m ³ /min	16.3 / 13.4 / 8.9 / 5.4
		Încălzire (P-Hi/Hi/Me/Lo)		17.8 / 13.7 / 10.9 / 6.2
	U.E.	Răcire/Încălzire		100 / 100
Exterior dimensions	U.I.	HeightxWidthxDepth	mm	305 x 920 x 220
	U.E.		mm	1,300 x 970 x 370
Greutate netă		U.I./U.E.	kg	13 / 99
Refrigerant Type GWP				R32/675
Ref.piping size	Lichid/Gaz		Ț,mm	9.52(3/8") / 15.88(5/8")
Lungime țeavă refrigerant (o direcție)			m	Max.100
Diferență de nivel suportată	Unitate externă este mai sus/mai jos		m	Max.50 / Max.15
Interval de funcționare - temperatură exterioară	Răcire*2		°C	-15~50
	Încălzire		°C	-20~20

Datorită politicii de continuă îmbunătățire a produselor, ne rezervăm dreptul de a modifica specificațiile tehnice fără nicio notificare prealabilă.



TEMPERATURE CONTROL FOR TODAY & TOMORROW



Filtru de aer, cantitate		Polypropylene net x 2(washable)
Telecomandă (opțional)		Cu fir:RC-EX3A, RC-E5, RCH-E3 & Interface kit:SC-BIKN2-E

Schema tehnica

FDC100VNX-W, 125VNX-W, 140VNX-W, 100VSX-W, 125VSX-W, 140VSX-W

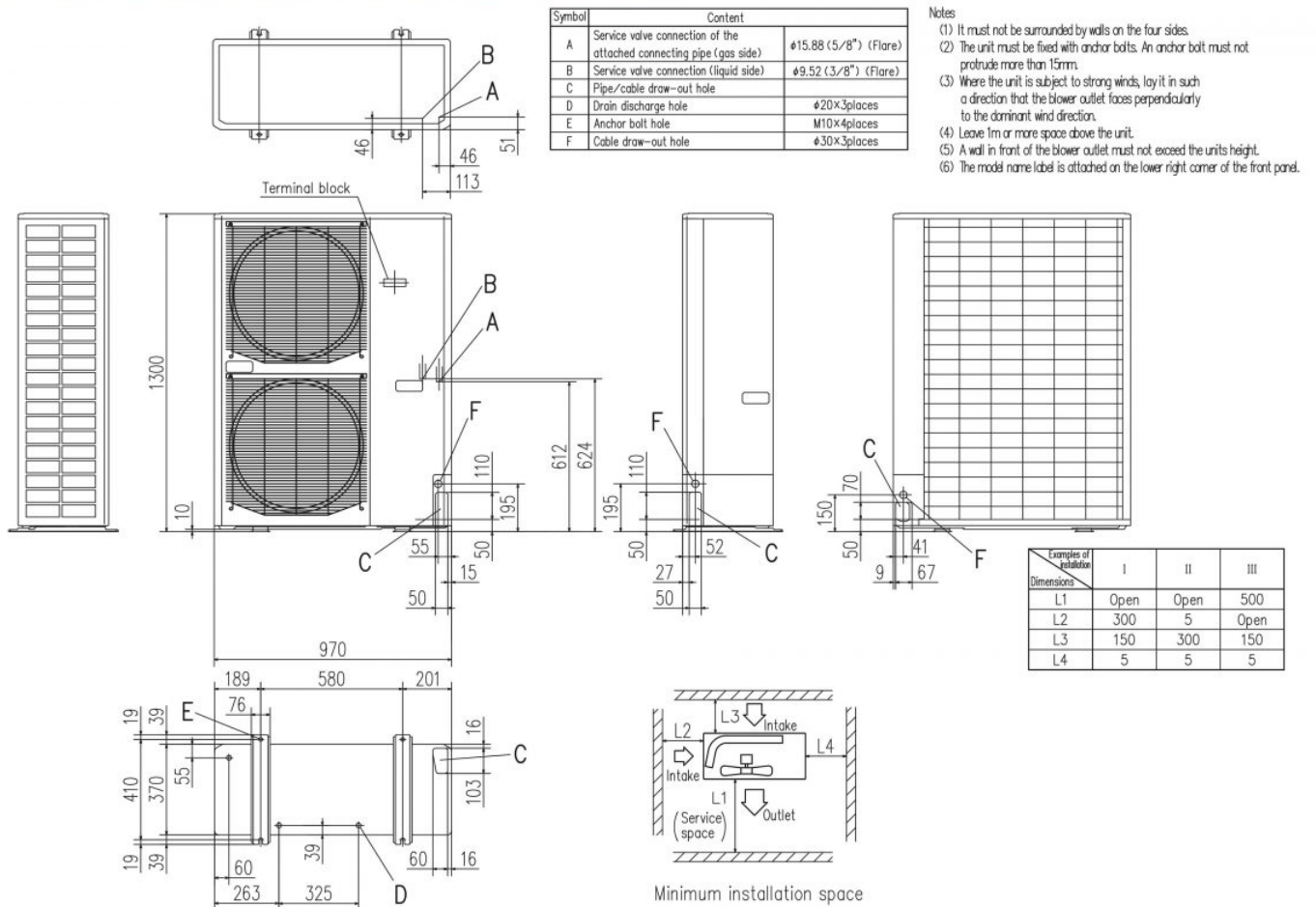

Datorită politicii de continuă îmbunătățire a produselor, ne rezervăm dreptul de a modifica specificațiile tehnice fără nicio notificare prealabilă.



TEMPERATURE CONTROL FOR TODAY & TOMORROW



SRK20ZSX-W, -WB, -WT SRK25ZSX-W, -WB, -WT
SRK35ZSX-W, -WB, -WT SRK50ZSX-W, -WB, -WT
SRK60ZSX-W, -WB, -WT

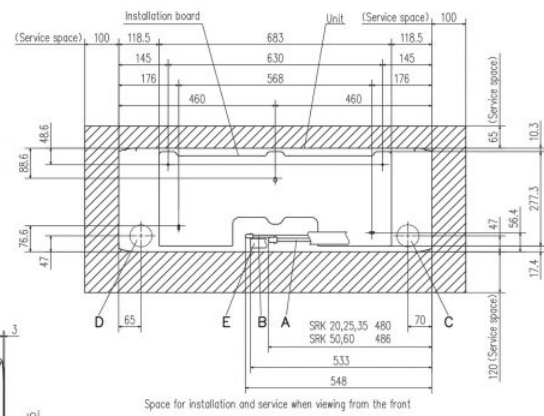
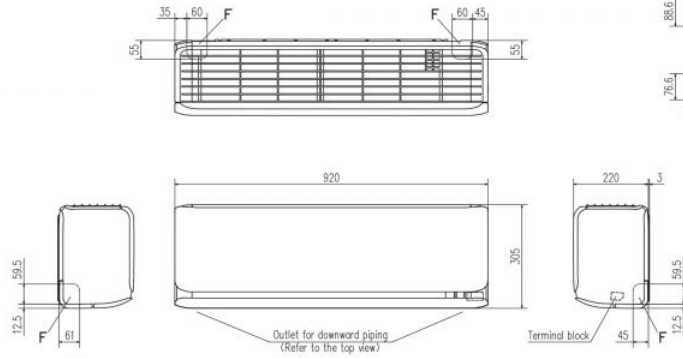

Space for installation and service when viewing from the front

Symbol	Content	
A	Gas piping SRK 20,25,35 SRK 50,60	#9.52 (3/8") (Flare) #12.7 (1/2") (Flare)
B	Liquid piping	#6.35 (1/4") (Flare)
C	Hole on wall for right rear piping	(#65)
D	Hole on wall for left rear piping	(#65)
E	Drain hose	VP16
F	Outlet for piping	

Datorită politicii de continuă îmbunătățire a produselor, ne rezervăm dreptul de a modifica specificațiile tehnice fără nicio notificare prealabilă.