



TEMPERATURE CONTROL  
FOR **TODAY & TOMORROW**

  
**MITSUBISHI**  
**HEAVY INDUSTRIES**

## SRK200VSAWPZR

Capacitate nominala de racire: **20.0 KW**



## Poze unitate interna si unitate externa



## Specificatii

Unitate internă		SRK100ZR-W (2 units)	
Unitate externă		FDC200VSA-W	
Sursă de alimentare		Trifazic 380-415V, 50Hz / 380V, 60Hz	
Capacitate nominală de răcire (Min-Max)		kW	20.0 ( 7.0 ~ 22.4 )
Capacitate nominală de încălzire (Min-Max)		kW	22.4 ( 6.6 ~ 25.0 )
Power Consumption	Răcire/Încălzire	kW	7.46 / 6.87
EER/COP	Răcire/Încălzire	kW	2.68 / 3.26



## TEMPERATURE CONTROL FOR TODAY & TOMORROW



Curent de intrare			A	5,19
Max. current			A	
Nivel putere sonoră*1	U.I.*3	Răcire/Încălzire	dB(A)	63
	U.E.	Răcire/Încălzire		72 / 74
Nivel presiune sonoră*1	U.I.*3	Răcire (P-Hi/Hi/Me/Lo)		48 / 45 / 40 / 27
		Încălzire (P-Hi/Hi/Me/Lo)		48 / 43 / 38 / 30
	U.E.	Răcire/Încălzire		58 / 59
Flux de aer	U.I.*3	Răcire (P-Hi/Hi/Me/Lo)	m <sup>3</sup> /min	24.5 / 21.3 / 17.6 / 10.4
		Încălzire (P-Hi/Hi/Me/Lo)		27.5 / 23.2 / 19.1 / 13.6
	U.E.	Răcire/Încălzire		148 / 134
Exterior dimensions	U.I.	HeightxWidthxDepth	mm	339 x 1197 x 262
	U.E.		mm	1505 x 970 x 370
Greutate netă		U.I./U.E.	kg	16.5 / 144
Refrigerant Type GWP				R32/675
Ref.piping size	Lichid/Gaz		Ț, mm	9.52(3/8") / 15.88(5/8")
Lungime țeavă refrigerant (o direcție)			m	Max.70
Diferență de nivel suportată	Unitate externă este mai sus/mai jos		m	Max.50 / Max.15
Interval de funcționare - temperatură exterioară	Răcire*2		°C	-15~50
	Încălzire		°C	-20~20

**Datorită politicii de continuă îmbunătățire a produselor, ne rezervăm dreptul de a modifica specificațiile tehnice fără nicio notificare prealabilă.**



# TEMPERATURE CONTROL FOR TODAY & TOMORROW



Filtru de aer, cantitate		Polypropylene net x 2(washable)
Telecomandă (opțional)		Cu fir:RC-EX3A, RC-E5, RCH-E Interface kit:SC- BIKN2-E

## Schema tehnica

FDC100VNA-W, 125VNA-W, 140VNA-W, 100VSA-W, 125VSA-W, 140VSA-W  
FDC100VNA, 125VNA, 140VNA, 100VSA, 125VSA, 140VSA

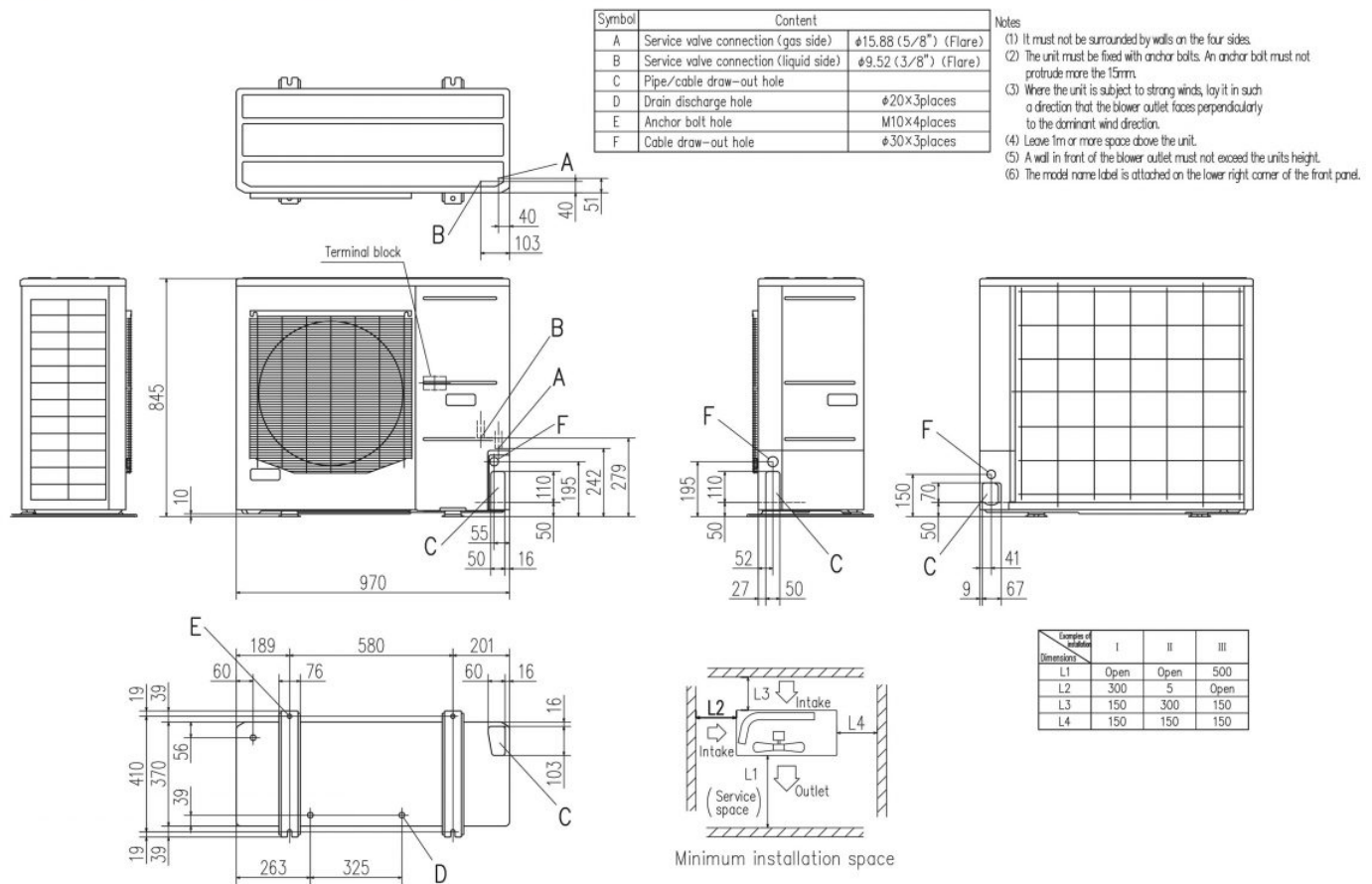

**Datorită politicii de continuă îmbunătățire a produselor, ne rezervăm dreptul de a modifica specificațiile tehnice fără nicio notificare prealabilă.**



# TEMPERATURE CONTROL FOR TODAY & TOMORROW



SRK63ZR-W SRK71ZR-W SRK80ZR-W  
SRK63ZR-S SRK71ZR-S SRK80ZR-S SRK100ZR-S

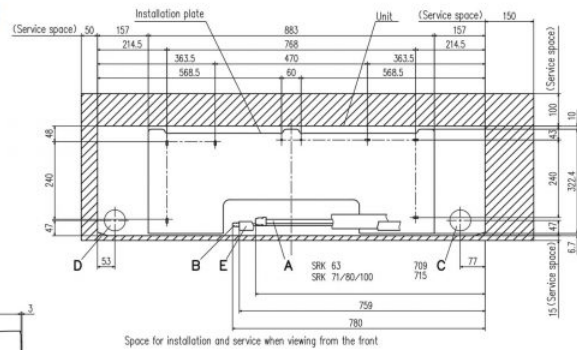
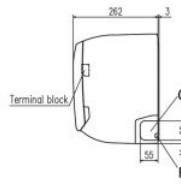
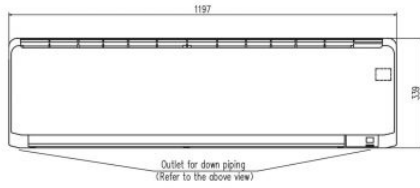

Symbol	Content
A	Gas piping SRK 63 #12.7 (1/2") (Flare) SRK 71,80,100 #15.88 (5/8") (Flare)
B	Liquid piping SRK 63,71,80 #6.35 (1/4") (Flare) SRK 100 #9.52 (3/8") (Flare)
C	Hole on wall for right rear piping (ø65)
D	Hole on wall for left rear piping (ø65)
E	Drain hose φ16
F	Outlet for wiring (on both side)
G	Outlet for piping (on both side)

**Datorită politicii de continuă îmbunătățire a produselor, ne rezervăm dreptul de a modifica specificațiile tehnice fără nicio notificare prealabilă.**