



TEMPERATURE CONTROL
FOR TODAY & TOMORROW

MITSUBISHI
HEAVY INDUSTRIES

SRK20ZS-WF / SRC20ZS-W

Capacitate nominala de racire: **2.0 KW**



Poze unitate interna si unitate externa



Specificatii

Unitate internă			SRK20ZS-WF
Unitate externă			SRC20ZS-W
Sursă de alimentare			Monofazic, 220 - 240, 50Hz
Capacitate nominală de răcire (Min~Max)		kW	2.0(0.9~2.9)
Capacitate nominală de încălzire (Min~Max)		kW	2.7(0.9~4.3)
Consum de energie	Răcire/Încălzire	kW	0.44 / 0.59
EER/COP	Răcire/Încălzire		4.55 / 4.58



TEMPERATURE CONTROL FOR TODAY & TOMORROW



Amperaj maxim			A	9
Nivel putere sonoră	U.I.	Răcire/Încălzire	dB(A)	48 / 50
	U.E.	Răcire/Încălzire		56 / 56
Nivel presiune sonoră	U.I.	Răcire (Hi/Me/Lo/Ulo)		34 / 25 / 22 / 19
		Încălzire (Hi/Me/Lo/Ulo)		36 / 29 / 23 / 19
	U.E.	Răcire/Încălzire		45 / 45
Flux de aer	U.I.	Răcire (Hi/Me/Lo/Ulo)	m ³ /min	9.3 / 7.0 / 5.9 / 5.0
		Încălzire (Hi/Me/Lo/Ulo)		10.0 / 8.5 / 6.5 / 5.9
	U.E.	Răcire/Încălzire		27.4 / 23.6
Dimensiuni exterioare	U.I.	Înălțime / Lățime /	mm	290 x 870 x 230
	U.E.	Adâncime		540 x 780(+62) x 290
Greutate netă	U.I. / U.E.		kg	9.5 / 31.0
Refrigerant		Tip/GWP		R32 / 675
Refrigerant		Încărcare		kg/TCO ₂ Eq
Dimensiuni țevă refrigerant		Lichid/Gaz		mm/ø
Lungime țevă refrigerant (o direcție)			m	Max. 20
Diferență de nivel suportată		Unitate externă este mai sus/mai jos		m
Interval de funcționare - temperatură exterioară		Răcire		°C

Datorită politicii de continuă îmbunătățire a produselor, ne rezervăm dreptul de a modifica specificațiile tehnice fără nicio notificare prealabilă.



TEMPERATURE CONTROL FOR TODAY & TOMORROW



Încălzire	-15~24	
Filtre		Filtru Antialergeni x1, Filtru lavabil fotocatalitic și dezodorizant x1
Clasa Energetică (Răcire/Încălzire)		A+++ / A++
SEER		10.00
SCOP (Climat temperat)		8.5
Pdesign (răcire/încălzire(@-10°C))	kW	2.00/2.60
Consumul anual de electricitate (răcire/încălzire)	kWh/a	83/793
Performanța pe modul încălzire		Climat temperat

Schema tehnica

Datorită politicii de continuă îmbunătățire a produselor, ne rezervăm dreptul de a modifica specificațiile tehnice fără nicio notificare prealabilă.



TEMPERATURE CONTROL FOR TODAY & TOMORROW



SRC20ZS-W SRC25ZS-W SRC35ZS-W SRC20ZS-S SRC25ZS-S SRC35ZS-S

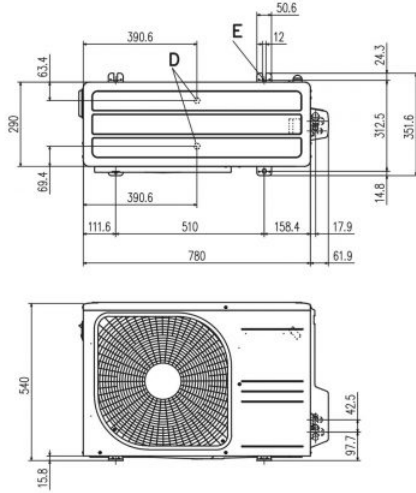

Symbol	Content
A	Service valve connection (gas side) $\phi 9.52$ (3/8") (Flare)
B	Service valve connection (liquid side) $\phi 6.35$ (1/4") (Flare)
C	Pipe/cable draw-out hole
D	Drain discharge hole $\phi 20 \times 2$ places
E	Anchor bolt hole M10 $\times 4$ places

Examples of Installation Dimensions	Minimum installation space			
	I	II	III	IV
L1	Open	280	280	180
L2	100	75	Open	Open
L3	100	80	80	80
L4	250	Open	250	Open

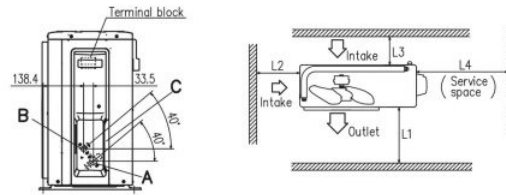

SRK20ZS-W,-WB,-WT SRK25ZS-W,-WB,-WT SRK35ZS-W,-WB,-WT SRK50ZS-W,-WB,-WT SRK20ZS-S,-SB,-ST SRK25ZS-S,-SB,-ST SRK35ZS-S,-SB,-ST SRK50ZS-S,-SB,-ST

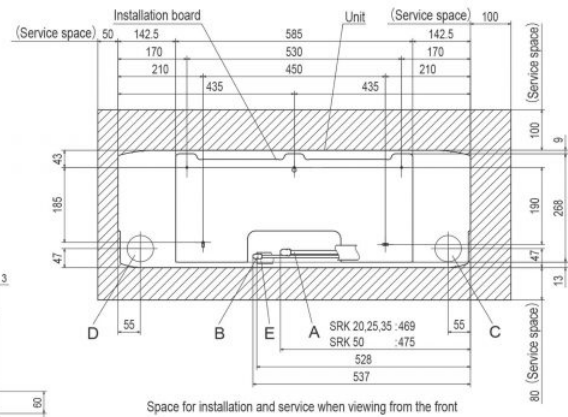
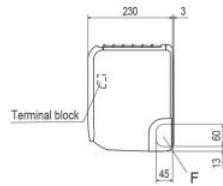
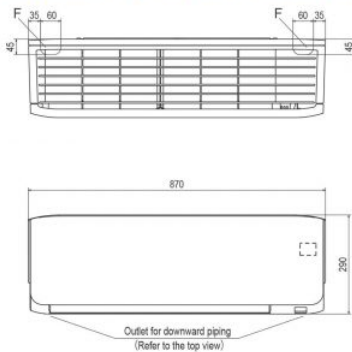

Symbol	Content
A	Gas piping SRK20, 25, 35 $\phi 9.52$ (3/8") (Flare)
B	Liquid piping SRK50 $\phi 12.7$ (1/2") (Flare)
C	Hole on wall for right rear piping ($\phi 65$)
D	Hole on wall for left rear piping ($\phi 65$)
E	Drain hose VP16
F	Outlet for piping (on both side)

Datorită politicii de continuă îmbunătățire a produselor, ne rezervăm dreptul de a modifica specificațiile tehnice fără nicio notificare prealabilă.