



TEMPERATURE CONTROL
FOR TODAY & TOMORROW

MITSUBISHI
HEAVY INDUSTRIES

SRR25ZS-W / SRC25ZS-W2

Capacitate nominala de racire: **2.5 KW**



Poze unitate interna si unitate externa



Specificatii

Unitate internă		SRR25ZS-W	
Unitate externă		SRC25ZS-W2	
Sursă de alimentare		Monofazic, 220 - 240, 50Hz	
Capacitate nominală de răcire (Min~Max)		kW	2.5 (0.9 ~ 3.2)
Capacitate nominală de încălzire (Min~Max)		kW	2.9 (0.9 ~ 4.4)
Consum de energie	Răcire/Încălzire	kW	0.62 / 0.65
EER/COP	Răcire/Încălzire		4.03 / 4.46



TEMPERATURE CONTROL FOR TODAY & TOMORROW



Amperaj maxim			A	9
Nivel putere sonoră	U.I.	Răcire/Încălzire	dB(A)	56 / 59
	U.E.	Răcire/Încălzire		58 / 58
Nivel presiune sonoră	U.I.	Răcire (Hi/Me/Lo/Ulo)		37 / 33 / 30 / 24
		Încălzire (Hi/Me/Lo/Ulo)		40 / 37 / 34 / 28
	U.E.	Răcire/Încălzire		47 / 47
Flux de aer	U.I.	Răcire (Hi/Me/Lo/Ulo)	m ³ /min	9.5 / 8.0 / 6.5 / 4.5
		Încălzire (Hi/Me/Lo/Ulo)		10.0 / 9.0 / 8.0 / 6.0
	U.E.	Răcire/Încălzire		27.4 / 23.6
Presiune statică externă disponibilă			Pa	35(Presiunea statică inițială cu filtru de aer: 5Pa)
Dimensiuni exterioare	U.I.	Înălțime / Lățime / Adâncime	mm	200 x 750 x 500
	U.E.			540 x 780(+62) x 290
Greutate netă	U.I. / U.E.		kg	20.5 / 31.0
Refrigerant		Tip/GWP		R32/675
Refrigerant		Încărcare	kg/TCO ₂ Eq	0.62 / 0.419
Dimensiuni țevă refrigerant		Lichid/Gaz	mm/ø	6.35(1/4") / 9.52(3/8")
Lungime țevă refrigerant (o direcție)			m	Max. 20

Datorită politicii de continuă îmbunătățire a produselor, ne rezervăm dreptul de a modifica specificațiile tehnice fără nicio notificare prealabilă.



TEMPERATURE CONTROL FOR TODAY & TOMORROW



Diferență de nivel suportată	Unitate externă estemai sus/mai jos	m	Max. 10 / Max.10
Interval de funcționare - temperatură exterioară	Răcire	°C	-15~46
	Încălzire		-15~24
Kit de admisie aer din partea inferioară (opțional)			UT-BAT1EF
Clasa Energetică (Răcire/Încălzire)			A++/A+
SEER			6.60
SCOP (Climat temperat)			4.10
Pdesign (răcire/încălzire(@-10°C))		kW	2.50/2.50
Consumul anual de electricitate (răcire/încălzire)		kWh/a	133/853
Performanța pe modul încălzire			Climat temperat

Schema tehnica

Datorită politicii de continuă îmbunătățire a produselor, ne rezervăm dreptul de a modifica specificațiile tehnice fără nicio notificare prealabilă.



TEMPERATURE CONTROL FOR TODAY & TOMORROW



Outdoor units

SRC20ZS-W, 25ZS-W, 35ZS-W
SRC25ZS-W1, 35ZS-W1
SRC25ZS-W2, 35ZS-W2

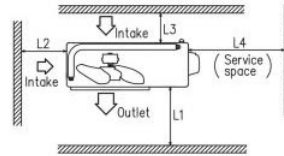
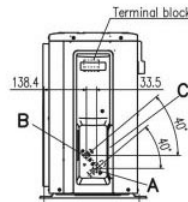
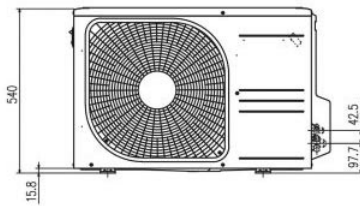
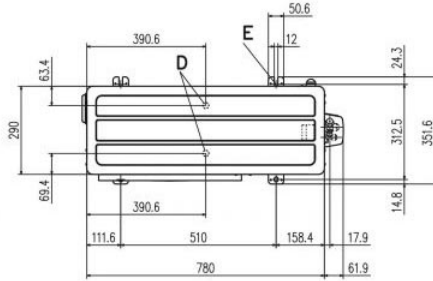

Symbol	Content
A	Service valve connection (gas side) $\phi 9.52$ (3/8") (Flare)
B	Service valve connection (liquid side) $\phi 6.35$ (1/4") (Flare)
C	Pipe/cable draw-out hole
D	Drain discharge hole $\phi 20 \times 2$ places
E	Anchor bolt hole $M10 \times 4$ places

Dimensions	Minimum installation space			
	I	II	III	IV
L1	Open	280	280	180
L2	100	75	Open	Open
L3	100	80	80	80
L4	250	Open	250	Open

SRR25ZS-W SRR35ZS-W SRR25ZM-S SRR35ZM-S

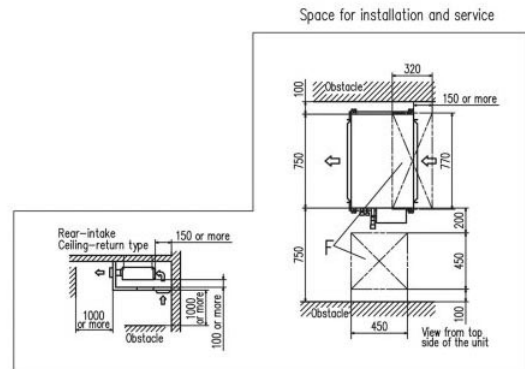
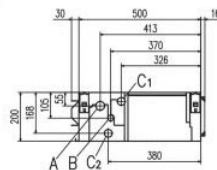
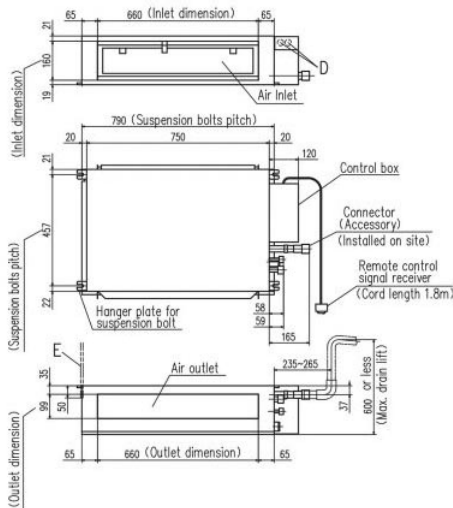

Symbol	Model	Content
A	Gas piping	$\phi 9.52$ (3/8") (Flare)
B	Liquid piping	$\phi 6.35$ (1/4") (Flare)
C1	Drain piping	VP25 (O.D.25, O.D.32) (Used with attached connector)
C2	Drain piping	VP25 (O.D.25, O.D.32) (Used with attached connector)
D	Wiring hole	$\phi 25 \times 2$
E	Suspension bolts	(M10)
F	Inspection hole	(450X450), (320X770)

Datorită politicii de continuă îmbunătățire a produselor, ne rezervăm dreptul de a modifica specificațiile tehnice fără nicio notificare prealabilă.